



MULTIVA

CULTIVATING THE FUTURE

Operation and maintenance manual
Seed drill

FORTE 300-400 EVO Comfort

Translation of the original manual

EN

www.multiva.info

Table of contents

1 Foreword	8
1.1 Purpose of the machine	8
1.2 Specifications	8
1.3 Type plate	11
1.4 Liability terms and conditions	11
1.5 Tightening torques	12
2 Warranty terms	13
3 Safety instructions	14
3.1 Residual risks	14
3.2 Symbols used in the operating manual	16
3.3 Warning labels used on the machine	18
3.4 Using the middle marker ball valves	25
4 Controllers	27
4.1 Comfort control system	27
4.1.1 Control system components	27
4.1.1.1 Speed sensor	27
4.1.1.2 Seeding position sensor	28
4.1.1.3 Hopper level sensors	28
4.1.1.4 Tramline clutches	29
4.1.1.5 Tramline extensions	30
4.1.1.6 Linear actuator for target rate	30
4.1.1.7 Coulter pressure gauge	31
4.1.2 Comfort controller buttons	32
4.1.3 User interface screens	33
4.1.4 Using the user interface	34
4.1.4.1 User setup	35
4.1.4.2 Adjusting the fertiliser target rate step	36
4.1.4.3 Seed drill parameters	37
4.1.4.4 Setting the tramline automation	38
4.1.4.5 Setting alarms	39
5 Commissioning and basic settings	41
5.1 Rendering to operating condition	41
5.1.1 Mounting the wheel packer	41
5.1.2 Mounting the drawbar cylinder	44
5.1.3 Attaching the turnbuckle	44
5.1.4 Mounting the front levelling board	45
5.1.5 Mounting the front harrow	47
5.1.6 Mounting the front disc cultivator	49
5.1.7 Mounting the track eradicators	51
5.1.8 Mounting the middle markers	54
5.1.9 Removing the transport supports	54
5.1.10 Fastening detached parts for packing	55
5.1.11 Mounting the scraper	56
5.1.12 Attaching a scraper to a seed drill with brakes	58
5.1.13 Mounting the rear harrow	60
5.1.14 Mounting the rear markers on the rear harrow	62
5.1.15 Mounting the front working platform to a machine with a standard drawbar	64

5.1.16	Mounting the front working platform to a machine with a front disc cultivator	68
5.1.17	Turning the rear railing of the working platform and attaching the end railing	72
5.2	Commissioning	74
5.2.1	Installing the Comfort control panel	74
5.3	Connecting to tractor	75
5.3.1	Adjusting the wheel packer boom length	78
5.3.2	Using the ground support	79
5.3.3	Adjusting the lengthwise level of the machine with a turnbuckle	79
5.3.4	Adjusting the lengthwise level of the machine with a drawbar cylinder	80
5.3.5	Using the machine lifting circuit ball valve	81
5.3.6	Using the transport wheels centre axle lift ball valve	82
5.3.7	Ensuring the steerability of the tractor	83
5.3.8	Adjusting the middle markers	83
5.3.9	Adjusting the width of the rear markers	85
6	Machine adjustment and use	86
6.1	Rendering the machine to the transport position	86
6.2	Rendering the machine to the working position	87
6.3	Comfort control system user settings	88
6.3.1	Active operating mode	88
6.3.2	Using middle markers	90
6.3.2.1	Selecting automatic and manual mode	90
6.3.2.2	Selecting middle markers	90
6.3.3	Using the tramline counter	91
6.3.3.1	Tramline counter correction	91
6.3.3.2	Tramline counter hold	91
6.3.4	Setting the fertiliser target rate	92
6.3.5	Selecting the remote control mode	93
6.3.6	Using the area counters	93
6.4	Feeders	94
6.5	Seeding quantities	94
6.6	Preparations preceding hopper filling	96
6.6.1	Preparations preceding fertiliser hopper filling	96
6.6.2	Preparations preceding seed hopper filling	96
6.6.3	Preparations preceding small seed filling	97
6.6.4	Adjusting the hopper divider on a machine with a small seed hopper	97
6.6.4.1	Hopper volumes with the small seed hopper dividers turned backwards	99
6.6.5	Adjusting the hopper divider on a machine with no small seed hopper	99
6.6.6	Adjusting the feeding quantity with the gearbox control lever	101
6.6.7	Adjusting the fertiliser hopper feeder units	102
6.6.7.1	Adjusting the bottom flap position	102
6.6.7.2	Adjusting the shut-off plate position	103
6.6.8	Adjusting the seed hopper feeder units	103
6.6.8.1	Adjusting the bottom flap position	103
6.6.8.2	Adjusting the shut-off plate position	104
6.6.9	Adjusting the small seed hopper feeder units	105

6.6.9.1	Adjusting the bottom flap position	105
6.6.9.2	Adjusting the shut-off plate position	106
6.6.10	Selection of small seed seeding method	106
6.7	Filling the hoppers	107
6.8	Product calibration	108
6.8.1	Fertiliser calibration test	110
6.8.2	Seed calibration test	113
6.8.3	Small seed calibration test	117
6.8.4	Calibration test with adjusting of the fertiliser target rate	122
6.9	Adjusting the seeding depth of the coulter	129
6.10	Adjusting the coulter pressure	130
6.11	Adjusting the rear harrow	131
6.12	Adjusting the front levelling board	132
6.13	Adjusting the front harrow	133
6.14	Adjusting the front disc cultivator	134
6.15	Using the track eradicator	136
6.15.1	Adjusting the track eradicator height	136
6.15.2	Replacing an S-tine point	136
6.16	Use of dispersing axles	137
6.16.1	Use of the fertiliser dispersing axle	137
6.16.2	Use of the seed dispersing axle	138
6.16.3	Use of a small seed pendulum disperser	138
6.17	Controlling the seeding depth	139
6.18	Securing the position of the middle markers	139
6.19	Brake system operation	140
6.19.1	Using the parking brake	140
6.19.2	Releasing brakes	140
6.19.3	Adjusting braking force	141
6.20	Emptying the hoppers	142
6.20.1	Emptying the hoppers to the calibration tray	142
6.20.2	Emptying the hoppers through the coulters	143
6.21	Emptying the small seed hopper	144
6.21.1	Emptying the hopper to the calibration tray	144
6.21.2	Emptying the small seed hopper through pipes	144
6.22	Disconnecting from the tractor	145
6.23	Machine storage	145
7	Maintenance	147
7.1	Inspections	148
7.1.1	Quick instructions, inspections	148
7.1.2	Checking bolt tightness	149
7.1.2.1	Checking the tightness of the wheel bolts of the transport wheels	149
7.1.2.2	Checking the tightness of the bolts in the flange bearings of the transport wheels	149
7.1.2.3	Checking the tightness of the wheel bolts of the wheel packer	150
7.1.2.4	Checking the tightness of coulter bolts	151
7.1.2.5	Checking the tightness of the working platform bolts ..	152
7.1.2.6	Checking the tightness of the towing eye bolts	153
7.1.3	Checking tyre pressure	153
7.1.4	Checking the bearing clearance of the wheel packer hubs	153

7.1.5	Checking the tightness of the transmission chains	154
7.1.5.1	Checking chain tightness, fertiliser and seed transmission	154
7.1.5.2	Checking chain tightness, small seed transmission	154
7.1.5.3	Checking chain tightness, fertiliser dispersing axle transmission	155
7.1.5.4	Checking chain tightness, seed dispersing axle transmission	155
7.1.6	Checking the tightness of the wheel drive chain	156
7.1.7	Inspecting the wheel drive clutch	157
7.1.8	Inspecting the wheel drive clutch	158
7.1.9	Checking the condition of hydraulics	158
7.1.10	Checking the condition of electric wires	158
7.1.11	Inspecting the towing eye	159
7.1.12	Checking the gearbox oil level	159
7.1.13	Inspecting the coulter discs	160
7.1.14	Checking the functioning of the adjusting of the fertiliser target rate	161
7.1.15	Checking the brake system	161
7.1.15.1	Checking brake pads	161
7.1.15.2	Draining water from the pneumatic tank	162
7.1.15.3	Checking the oil level in the pneumatic-hydraulic converter	162
7.1.15.4	Cleaning palm coupling filters	163
7.2	Lubrication	163
7.2.1	Quick instructions, lubrication	164
7.2.2	Lubricating the transmission chains	165
7.2.2.1	Chain lubrication, fertiliser- and seed hopper transmission	165
7.2.2.2	Chain lubrication, small seed hopper transmission	165
7.2.3	Lubricating the wheel drive	166
7.2.3.1	Lubricating the wheel drive chain	166
7.2.3.2	Lubricating wheel axle bearings	167
7.2.4	Lubricating the rear axle mounting	168
7.2.5	Lubricating the wheel axle bearings	168
7.2.6	Lubricating the lifting cylinder	169
7.2.7	Lubricating the towing eye	169
7.2.8	Lubricating the middle marker cylinders	170
7.2.9	Lubricating the rear marker cylinders	170
7.2.10	Lubricating the wheel packer pins and wheel hubs.	171
7.2.11	Lubricating the cylinders of the front levelling board	172
7.2.12	Lubricating the front harrow cylinders	173
7.2.13	Lubricating the front disc cultivator cylinders	173
7.2.14	Lubricating the drawbar cylinder	174
7.2.15	Lubricating the turnbuckle	174
7.2.16	Lubricating the parking brake lever shafts	175
7.2.17	Lubricating the parking brake crank	175
7.2.18	Lubricating the transport wheels centre axle lift cylinder	176
7.3	Cleaning	176
7.3.1	Cleaning the hoppers	176
7.3.2	Cleaning of the small seed hopper	177

7.3.3	Cleaning the paint surface	178
7.3.4	Cleaning the coulter discs	178
7.3.5	Cleaning the feeder units	179
7.3.6	Cleaning of the small seed hopper feeder units	179
7.4	Transport wheel assembly	180
7.4.1	Dismounting the wheel assembly	180
7.4.2	Disassembling a wheel assembly	184
7.4.3	Mounting a wheel assembly	185
7.4.4	Mounting the wheel assembly	186
7.5	Tightening the transmission chains	187
7.5.1	Tightening the chains, fertiliser and seed transmission	187
7.5.2	Chain tightening, small seed transmission	188
7.5.3	Chain tightening, fertiliser dispersing axle transmission	189
7.5.4	Chain tightening, seed dispersing axle transmission	190
7.6	Wheel hub bearing clearance of the wheel packer	191
7.6.1	Tightening the bearing	191
7.7	Wheel drive	192
7.7.1	Tightening the wheel drive chain	192
7.7.2	Replacing the wheel drive clutch	193
7.7.2.1	Dismounting the clutch	193
7.7.2.2	Installing the clutch	193
7.8	Towing eye	194
7.8.1	Replacing the towing eye	194
7.8.1.1	Detaching the towing eye	194
7.8.1.2	Installing the towing eye	194
7.9	Coulters	195
7.9.1	Replacing a coulter	195
7.9.1.1	Demounting a coulter	195
7.9.1.2	Installing a coulter	196
7.9.2	Replacing a coulter disc	198
7.9.2.1	Detaching a disc	198
7.9.2.2	Installing a disc	199
7.9.3	Replacing a coulter bearing	200
7.9.3.1	Detaching a bearing	200
7.9.3.2	Installing a bearing	201
7.9.4	Replacing the coulter covering wheel	202
7.9.4.1	Demounting the covering wheel	202
7.9.4.2	Installing the covering wheel	203
7.9.5	Adjusting the scrapers	203
7.9.5.1	Adjusting the disc scraper	203
7.9.5.2	Adjusting the cover wheel scraper	204
7.10	Comfort control system maintenance	204
7.10.1	Manual calibration of the speed sensor	204
7.10.2	Calibration of the speed sensor while driving	205
8	Fault situations	207
8.1	Troubleshooting the Comfort control system	207
8.2	Troubleshooting of the seed drill	209
9	Attachments	211
9.1	EC Declaration of Conformity	212
9.2	Hydraulic schematics	213
9.3	Electrical schematics	218

9.4 Connection socket according to SFS 2473	221
9.5 Calculating the stability of the tractor - seed drill combination	222

1 Foreword

Thank you for trusting us by choosing a high-quality Multiva FORTE EVO seed drill. We hope the product will meet your requirements and provide years of reliable service. Please read this manual thoroughly before operating the machine. It is important that you perform the inspection and maintenance measures specified in this manual to ensure flawless operation of the machine and validity of its warranty. You must follow all the instructions, warnings and prohibitions related to the use of the machine. They are provided to ensure operator safety and the long service life of the machine.

These instructions cover the FORTE 300 EVO and FORTE 400 EVO seed drills and the Comfort control systems.

1.1 Purpose of the machine

The operator of the seed drill must acquaint themselves with the machine and read and understand the contents of its operating manual before operating the machine. The seed drill may only be operated when it is in a flawless technical condition. The seed drill must be used in accordance with regulations, identifying hazards and following the safety and operating instructions.

Original Multiva spare parts and accessories are designed for this particular seed drill. The manufacturer bears no responsibility for spare parts and accessories provided by other suppliers. Using them in certain circumstances may weaken the machine and compromise personal safety.

The machine is intended for sowing seeds and applying fertiliser. When the machine is in its working position, the coulters may come into contact with one another during sharp turns. The maximum permissible turning angle in the working position is 30°.

The construction of the machine allows road transport with the hoppers full. Any use exceeding this, such as using the machine for transport, is not considered to be in accordance with the regulations. Use in accordance with the regulations includes following the operating instructions and manufacturer's instructions as well as regulations concerning service and maintenance. Occupational safety regulations concerning agricultural machinery, other rules and regulations on general safety technology and occupational health as well as traffic rules and regulations must be followed.

1.2 Specifications

Table. 1.2 - 1. Specifications

Specifications	FORTE 300 EVO	FORTE 400 EVO
Working width (cm)	300	400
Transportation height (cm)	340 with middle markers	390 with middle markers
	260 without middle markers	260 without middle markers

Transportation width (cm)	300	409
Hopper filling height (cm)	215	
Weight (kg)	4,200	5,500
Hopper volume (L)	3,800	5,300
Small seed hopper volume (L)	370	510
Coulter pressure (kg)	50- 250	
Tyres	250/80-18	
Coulters (pcs)	20	26
Furrow spacing (mm)	150	154
Recommended working speed (km/h)	8- 12	
Normal track width of tramline (mm)	1,650	1,694
Alternative track width of tramline (mm)	1,950	2,002
Extended track width of tramline (mm)	1,800	1,848
Tractor power requirement (hp)	90	120

Table. 1.2 - 2. Accessories, FORTE 300 EVO and FORTE 400 EVO

<p>Towing method (select one of the following)</p> <ul style="list-style-type: none"> • Hitch • Wheel packer • Wheel packer with a front disc cultivator
<p>Rear axle system (choose one of the following)</p> <ul style="list-style-type: none"> • Without brakes • Hydraulic brakes, single line <ul style="list-style-type: none"> ◦ connected to the tractor hydraulic system ◦ cable-operated parking brake ◦ FORTE 400 EVO: transport wheels centre axle lift • Pneumatic brakes, dual line <ul style="list-style-type: none"> ◦ equipped with a pneumatic-hydraulic converter ◦ connected to the tractor hydraulic system ◦ cable-operated parking brake ◦ FORTE 400 EVO: transport wheels centre axle lift

Transmission

- Gearbox for seed
- Gearbox for fertiliser
- Gearbox for small seed

Wheel drive from transport wheels

Covering wheel scrapers

Middle markers

Front accessories

- Front working platform
- Drawbar cylinder
- Front levelling board
 - available with the wheel packer
- Front levelling board
 - available with the wheel packer
- Front disc cultivator
 - the wheel packer is included in the delivery of the front disc cultivator
- Track eradicator

Rear accessories

- Rear harrow
- Rear markers for the rear harrow
- Scraper for the rear wheels
- Rear lights
- Lights and reflectors'

Hopper accessories

- Adjustable hopper dividers
- Small seed feeders
- Sieves for fertiliser hopper
- Seed sieves
- Fertiliser dispersing axle
- Seed dispersing axle
- Small seed pendulum disperser

Controller type (select one of the following):

- Comfort controller
- SeedPilot controller - with a 7" display
- SeedPilot ISOBUS controller, no display included

Accessories suitable for controllers

- Dual hopper level sensors
- Adjusting of fertiliser target rate
- Adjusting of seed target rate
- Tramline extensions

Transport set - 2.45 m

1.3 Type plate

The type plate is located on the left side of the machine, under the transmission cover.

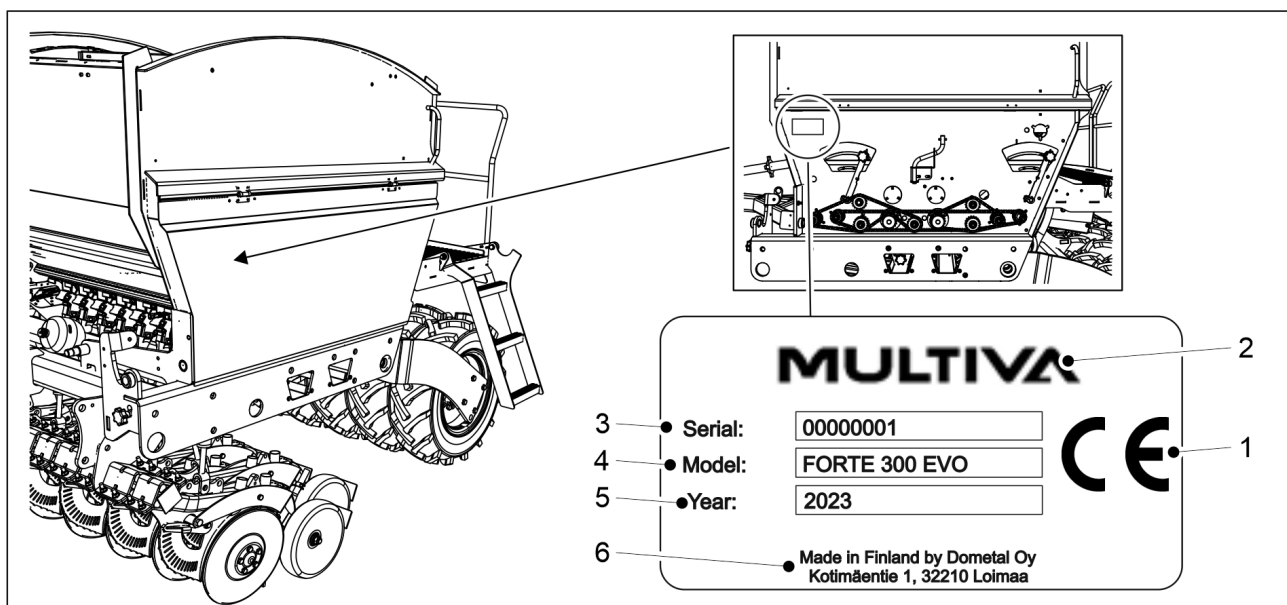

Figure. 1.3 - 1. Location and details of the type plate

Table. 1.3 - 3. Details of the type plate

1.	CE marking
2.	Machine manufacturer
3.	Machine serial number
4.	Machine model
5.	Manufacturing year
6.	Manufacturer's information

1.4 Liability terms and conditions

The FORTE EVO seed drills have been quality inspected and their operation has been tested before delivery. However, the owner/operator is responsible for the operation of the machine in practical circumstances. Damage compensation claims not concerning the machine itself as well as those concerning damages caused by misuse or incorrect adjustments of the machine will be rejected.

The machine manufacturer is not liable for any use of the machine that is in violation of laws, safety regulations or this operating manual.

Note that inappropriate use of fertilisers and plant protecting agents may cause damage to plants, humans, animals, water system or soil. Follow the instructions provided by the manufacturers of these substances and other experts as well as the authorities in handling and using said substances.

The manufacturer is not responsible for the selection of an incorrect quantity of seeds, plant protecting agents or fertiliser or incorrect seeding depth. The operator must constantly make sure that the desired seeding depth is maintained. If you lack information or knowledge gained through experience, please consult an expert for advice. The manufacturer is not responsible for any failures in seeding. The operator must continuously monitor the consumption of seeds and fertiliser in order to make sure that sowing quantities stay at a proper level in all seeding coulters.

The manufacturer is not liable for damages caused by the use of components provided by other manufacturers. The manufacturer is not liable for damage caused to other machines or equipment that result from the use of this machine. The manufacturer reserves the right to develop or modify the construction of the machine. The owner of the machine is responsible for ensuring that all operators of the machine acquaint themselves with the machine's operating and safety instructions.

1.5 Tightening torques

The table below shows the tightening torques of steel screws and nuts. If the tightening torque to be used should be something other than what is listed in the table, the tightening torque will be provided with the task instructions.

Table. 1.5 - 4. Tightening torques of steel screws and nuts

Steel screws and nuts: 8.8 Zn	
Thread	Torque (Nm)
M8	15
M12	90
M16	230
M18	250
M20	350









2 Warranty terms





1. The machine's warranty period is 12 months.
2. The warranty period starts on the date when an authorised retailer delivers the machine.
3. The warranty covers manufacturing and raw material defects. Damaged parts are repaired or replaced with parts in proper operating condition at the customer's facilities, factory or authorised repair shop.
4. A warranty repair does not extend the warranty period.
5. Warranty does not cover:
 - damage caused by incorrect operation or maintenance in violation of the operating manual, excessive loading or normal wear.
 - loss of income, downtime, other consequential or indirect damage caused to the product's owner or a third party
 - travel or freight expenses, daily allowances
 - changing the original construction of the product.







In warranty matters, please contact the machine retailer or manufacturer. Any measures and costs must always be agreed upon with the manufacturer before the measures are taken.

3 Safety instructions

3.1 Residual risks

	<p>Read this operating and maintenance manual thoroughly before operating the machine and follow the instructions given.</p>
	<p>Crushing hazard when connecting and disconnecting the seed drill. Minimum safe distance 5 m. Exercise extreme caution when someone else is near the seed drill and tractor giving instructions on connecting and disconnecting.</p>
	<p>Crushing and impact hazard when lifting and lowering the centre markers. When lifting and lowering the middle markers, ensure that there are no personnel in the vicinity. When raising and lowering the machine, the minimum safe distance is 5 m. Before performing the calibration test, ensure that the middle marker ball valves are closed.</p>
	<p>Crushing and impact hazard when lifting and lowering the middle markers. When lifting and lowering the middle markers ensure that there are no personnel in the vicinity. When raising and lowering the machine, the minimum safe distance is 5 m.</p>
	<p>Crushing hazard when the accessories are being adjusted. Before adjusting the accessories, make sure that the tractor is turned off, the key is removed from the ignition and the parking brake is engaged.</p>
	<p>Be careful not to crush or cut your hand or fingers in the feeder of the hopper.</p> <p>Ensure that the controller and tractor are turned off, the key is removed from the ignition and the parking brake is engaged when there are personnel in the hopper or near the machine.</p>
	<p>There is a crushing hazard underneath the machine and a cutting hazard in the machine's transmission when performing servicing and maintenance. Before servicing, make sure that power is switched off in the tractor, the key is removed from the ignition and the parking brake is engaged.</p>
	<p>Crushing hazard when lifting and lowering the seed drill. When lifting and lowering the machine, make sure nobody is in its vicinity. Minimum safe distance 5 m.</p> <p>There is a crushing hazard when performing servicing and maintenance. Before servicing, ensure that stoppers have been placed on the cylinder rods and that the machine has been supported from underneath with a block or similar. Never go under the machine that is not propped up.</p>



	<p>Hydraulic hoses under pressure may release a life-threatening jet of liquid. High-pressure liquid may also cause a crushing, cutting or impact hazard.</p> <p>The hydraulic system must be depressurised before pressure hoses are handled, connected or disconnected. Depressurise the hydraulic system and disconnect the hoses before maintenance work.</p> <p>Never touch the hydraulic cylinders, hoses and hydraulic connectors when the cylinders are in operation.</p>
	<p>Falling hazard when performing work on the working platform and front platform. Accessing the steps of the platform is allowed only when the machine is lowered. Be careful when performing work on the working platform and front platform.</p>
	<p>Falling hazard. Staying on top of the machine, wheels and sensors is always prohibited.</p>
	<p>Before moving and servicing, ensure that the middle markers have settled in the transport position and that their ball valves are closed.</p>
	<p>Before performing a calibration test, ensure that the tractor's parking brake is engaged, the middle markers have settled in the transport position and their ball valves are closed.</p>

	<p>Crushing hazard when lifting the seed drill from a bed using a hoist. Minimum safe distance 10 m. Exercise extreme caution.</p>
	<p>Crushing and cutting hazard when installing the drawbar, front equipment, rear harrow, middle markers and drawbar cylinders. Exercise extreme caution.</p>
	<p>Before moving, ensure that the tractor's hitch is locked.</p>
	<p>Crushing and cutting hazard when removing the wheels. Exercise caution when handling the wheels.</p>
	<p>Depressurise the hydraulic system, disconnect the hoses and tractor's electrical connections and let the machine cool off before servicing.</p>
	<p>Avoid breathing seed dressing dust and fertiliser dust when filling the hopper. The seed dressing causes a serious health risk. Read the material safety data sheet of the dressing agent and fertiliser and follow their warnings.</p>
	<p>Never go under a lifted load when filling the hopper.</p>

	Make sure that nobody is on top of the seed drill or inside the hopper when filling the hopper.
---	---

	Wear protective gloves when handling oil or grease and when connecting and disconnecting hydraulic components. Avoid skin contact with oil and grease to prevent skin irritation and damage.
---	--

3.2 Symbols used in the operating manual

	DANGER warns of a dangerous situation which may lead to death or serious physical injury.
	CAUTION warns of a dangerous situation which may lead to damage to the equipment.
	ADVICE contains useful tips, advice and information in the instructions e.g. on tightening torques, adjusting values, liquid quantities and special tools.

 **DANGER**
When connecting and disconnecting hydraulic hoses and electrical wires, ensure that the tractor is turned off and the key is removed from the ignition.

 **DANGER**
Never adjust or clean a moving seed drill.

 **DANGER**
Never stand or sit on top of the seed drill or within its operating area during operation. Minimum safe distance 5 m.

 **DANGER**
Inspect the condition of the seed drill at least visually before moving or operating it. Items to be inspected include tyre pressure, machine cleanliness and the tightness of the bolts of the towing device.

 **DANGER**
Before seeding, make sure that the machine is in working order. Make sure that the hoses are intact and have no leaks. Make sure that the coulters and mechanics are intact. Specifically ensure that all the pins are in place.

 **DANGER**
When transporting the seed drill on public roads, exercise caution and observe all road traffic regulations, as well as specific regulations concerning slow-moving vehicles.

 **DANGER**
Before moving the tractor, check that the slow-vehicle triangle is visible and tractor lights are lit and visible. Keep the triangle and lights clean, because they have a considerable impact on the vehicle's traffic safety.

**DANGER**

The maximum allowed transportation speed of the seed drill is 40 km/h on a road that is in good condition and even. The maximum allowed transportation speed of the seed drill is 25 km/h on damaged roads

**DANGER**

When replacing hydraulic system components and conductors, only use spare parts with sufficient pressure resistance.

**DANGER**

Never use oil or lubrication grease to clean skin. These substances may contain small metal particles, which cause irritation of the skin or cuts. Follow the handling instructions and safety regulations of the lubricant manufacturers. Synthetic oils are often corrosive and cause strong irritation of the skin. Contact a doctor, if oil or grease causes injuries.

**DANGER**

Never spray water directly on electric equipment.

**CAUTION**

Before servicing, ensure that the machine lifting ball valve is closed and the cylinders are equipped with stoppers.

**CAUTION**

Use original machine spare parts whenever servicing and repairing the seed drill. Using generic parts will void the warranty.

**CAUTION**

Collect oil waste and dispose of it appropriately in accordance with national regulations.

**CAUTION**

If oil is spilled on the ground, absorb it with absorption material, such as turf, to prevent the oil spill from spreading. Handle the absorption material in accordance with regulations.

**CAUTION**

Clean the machine whenever you change fertiliser or seed types.

**CAUTION**

If the machine will be unused overnight or over a long rain season, empty its fertiliser hopper in advance and clean the roller grooves of the feeder. Otherwise, the fertiliser may dissolve and clog the feeders.

**CAUTION**

Before using a detergent, make sure it is appropriate for washing a seed drill. Follow the safety and operating instructions of the detergent manufacturer.

3.3 Warning labels used on the machine

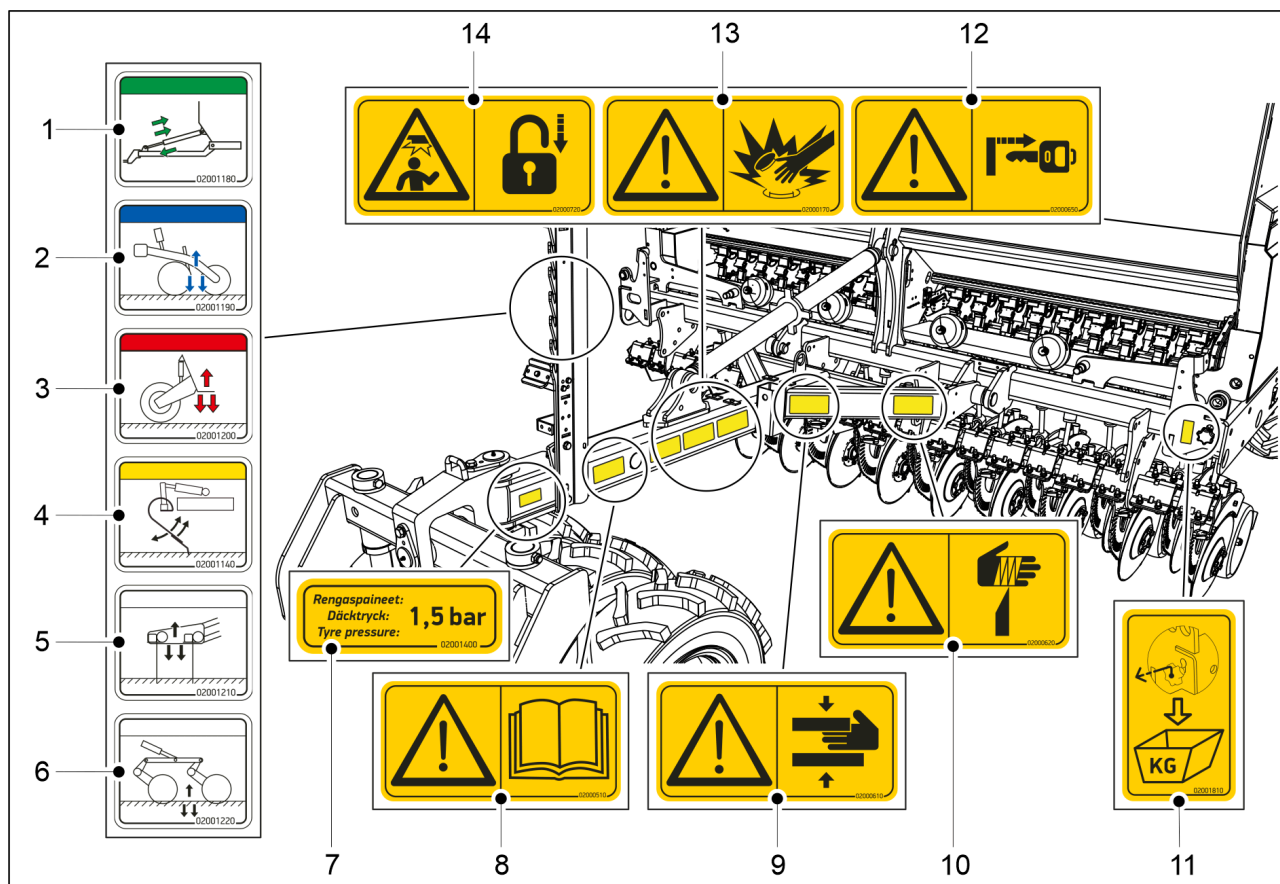

Figure. 3.3 - 2. Warning labels on the seed drill drawbar and front

Table. 3.3 - 5. Warning labels on the seed drill drawbar and front

1.	Hydraulic connection of the drawbar adjustment (optional)	1 pcs
2.	Hydraulic connection of the coulter pressure	1 pcs
3.	Machine lifting hydraulic connection	1 pcs
4.	Hydraulic connection of the adjustment of the front levelling board position	1 pcs
5.	Hydraulic connection of the front levelling board position adjustment	1 pcs
6.	Hydraulic connection of the front disc cultivator position adjustment	1 pcs
7.	Tyre pressure sticker	1 pcs
8.	Read the operation and maintenance manual carefully before operation	1 pcs
9.	Crushing hazard when connecting and disconnecting the seed drill - minimum safety distance 5 m.	1 pcs
10.	Cutting hazard	1 pcs
11.	Calibration test adjuster rod sticker	1 pcs
12.	Before adjusting the seeding depth and accessories, make sure that the tractor is turned off, the key is removed from the ignition and the parking brake is engaged.	1 pcs

13.	Beware of pressurised hydraulic hoses	1 pcs
14.	Ensure that the tractor's parking brake is engaged and the marker ball valve is in the closed position before performing the calibration test. Ensure that the markers have settled in the transport position and their ball valves have been closed before moving.	1 pcs

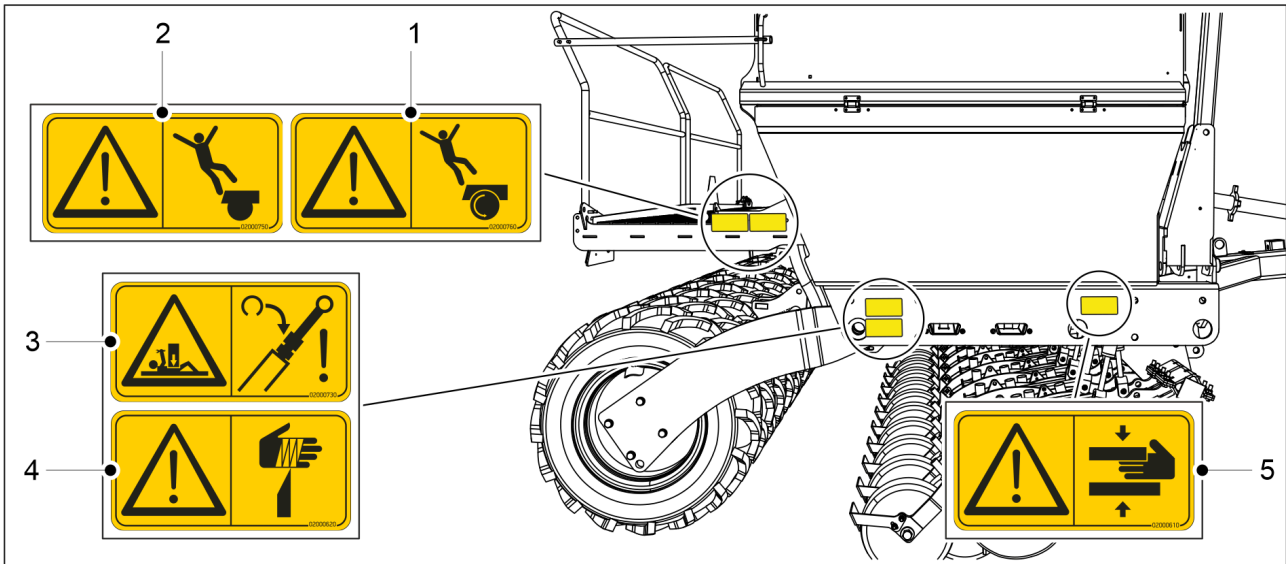

Figure. 3.3 - 3. Right-side warning labels of the seed drill

Table. 3.3 - 6. Right-side warning labels of the seed drill

1.	Falling hazard, do not climb on top of the wheel	1 pcs
2.	Falling hazard	1 pcs
3.	Crushing hazard when performing servicing and maintenance.	1 pcs
4.	Cutting hazard	1 pcs
5.	Crushing hazard	1 pcs

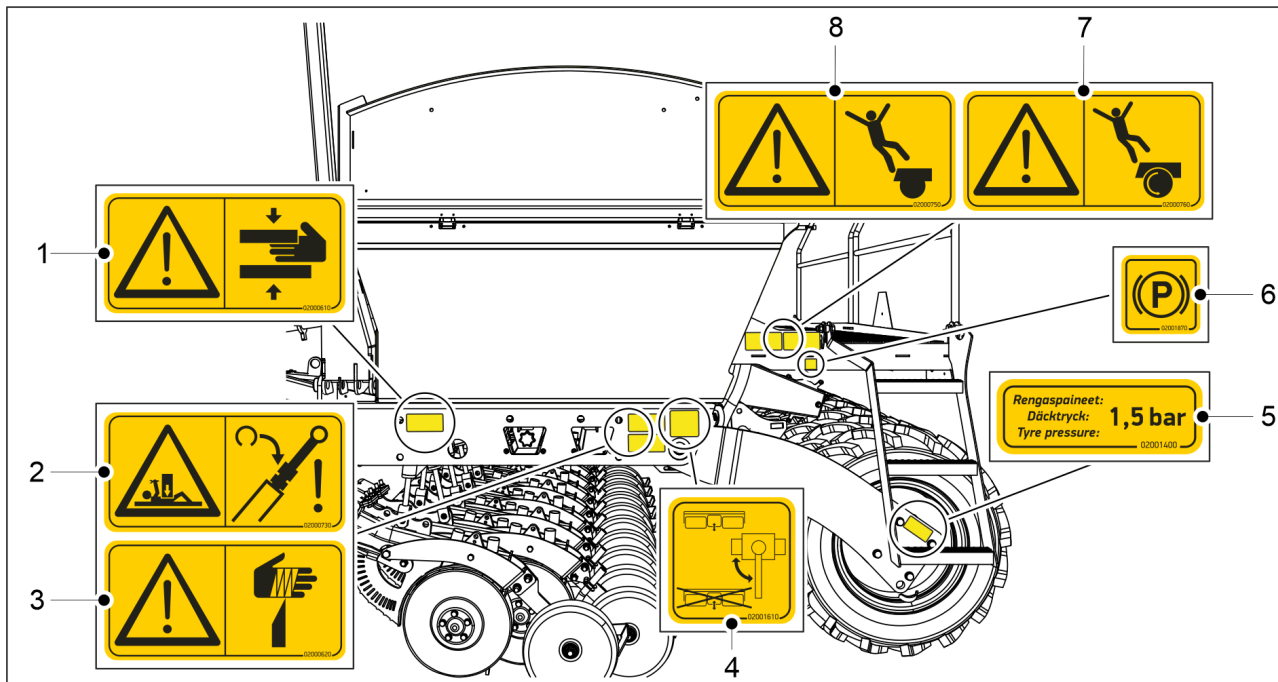

Figure. 3.3 - 4. Left side warning labels of the seed drill

Table. 3.3 - 7. Left side warning labels of the seed drill

1.	Crushing hazard	1 pcs
2.	Crushing hazard when performing servicing and maintenance.	1 pcs
3.	Cutting hazard	1 pcs
4.	Instruction label for operating the ball valve <ul style="list-style-type: none"> • concerns lifting of transport wheels centre axle • only 400 machines with a braking system 	1 pcs
5.	Tyre pressure label	1 pcs
6.	Parking brake label <ul style="list-style-type: none"> • only machines with a braking system 	1 pcs
7.	Falling hazard, do not climb on top of the wheel	1 pcs
8.	Falling hazard	1 pcs

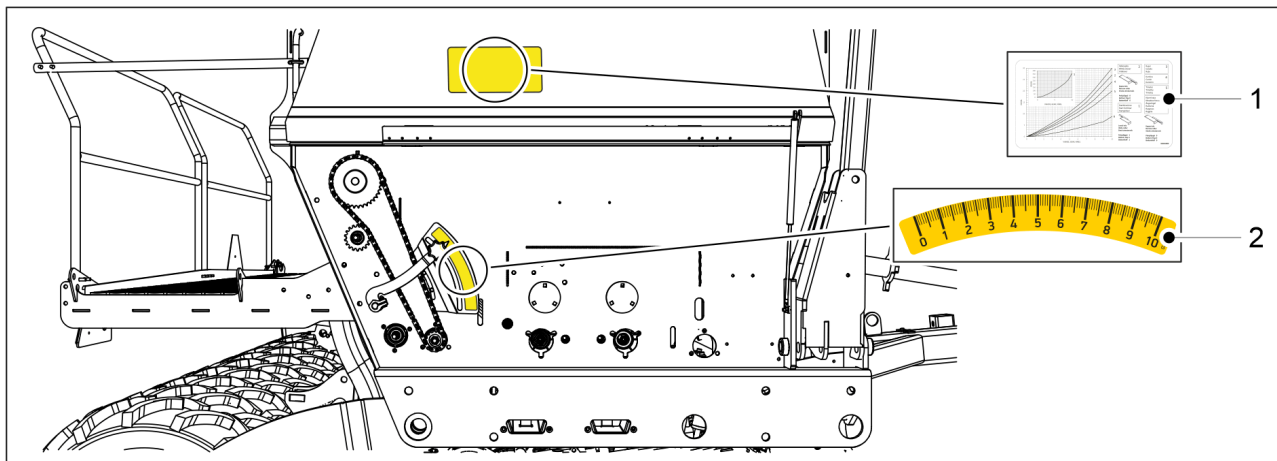

Figure. 3.3 - 5. Right-side seeding- and control labels of the seed drill

Table. 3.3 - 8. Right side seeding- and control labels of the seed drill

1.	Seeding quantities label	1 pc for small seeds
2.	Adjustment scale	1 pcs

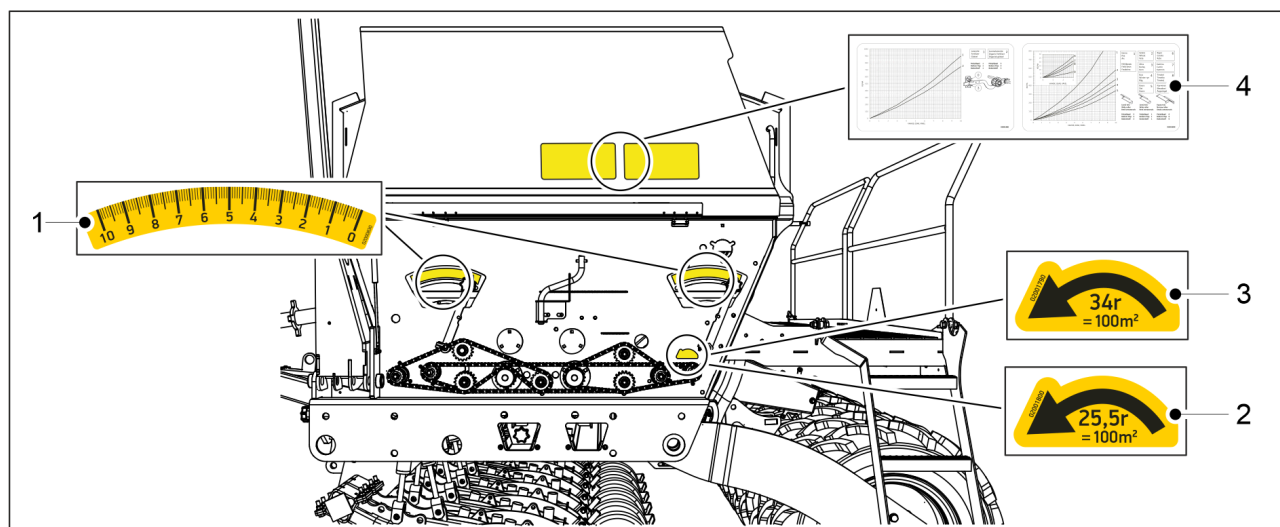

Figure. 3.3 - 6. Left side seeding and control labels of the seed drill

Table. 3.3 - 9. Left side seeding and control labels of the seed drill

1.	Adjustment scale	2 pcs
2.	Rotation direction of the calibration test and number of rotations	1 pc (FORTE 400 EVO)
3.	Rotation direction of the calibration test and number of rotations	1 pc (FORTE 300 EVO)
4.	Seeding quantities stickers	1 pc for fertiliser, 1 pc for seed

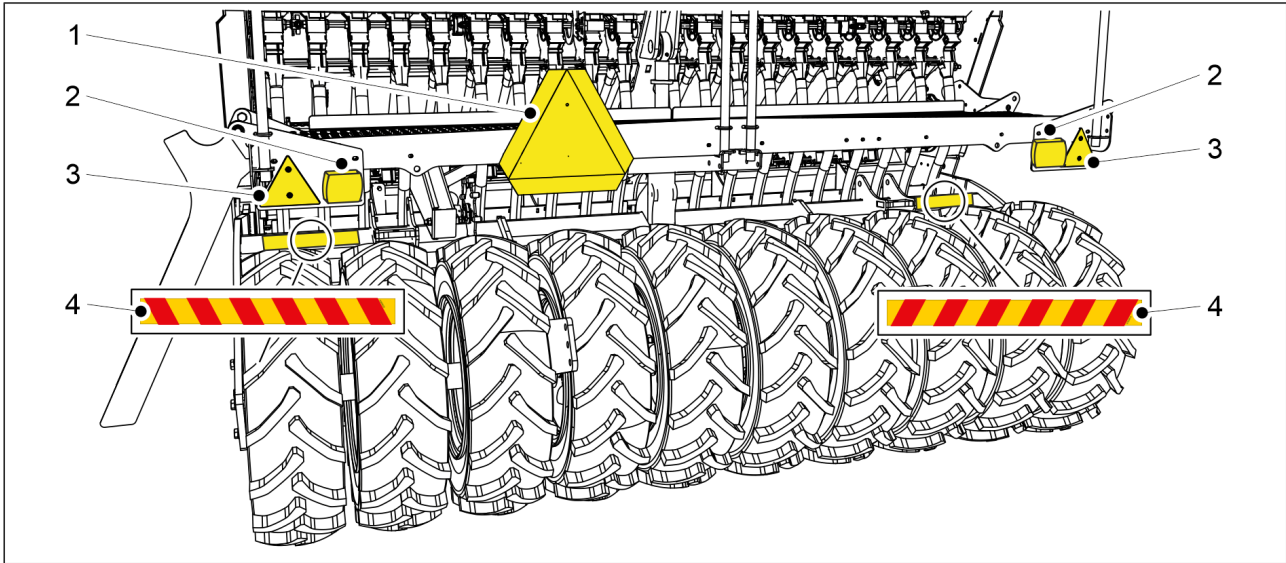

Figure. 3.3 - 7. Labels, reflectors and lights of the rear of the seed drill

Table. 3.3 - 10. Labels, reflectors and lights of the rear of the seed drill

1.	Plate slow vehicle	1 pcs
2.	Rear light	2 pcs
3.	Reflector	2 pcs
4.	Warning tape	2 pcs

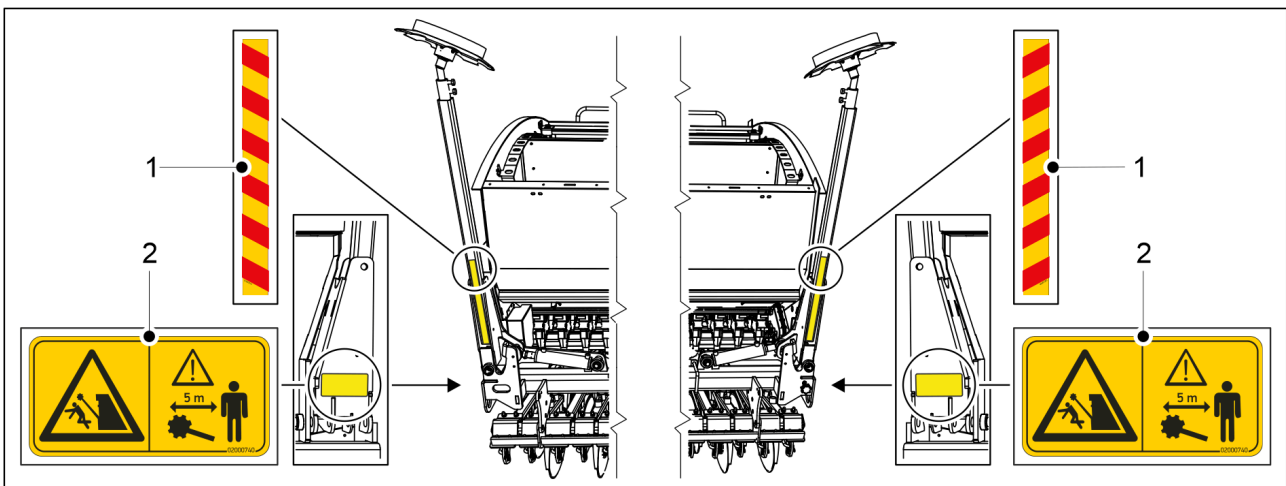

Figure. 3.3 - 8. Middle marker warning labels

Table. 3.3 - 11. Middle marker warning labels

1.	Warning tape	2 pcs
2.	Crushing and impact hazard when lifting and lowering the middle markers	2 pcs

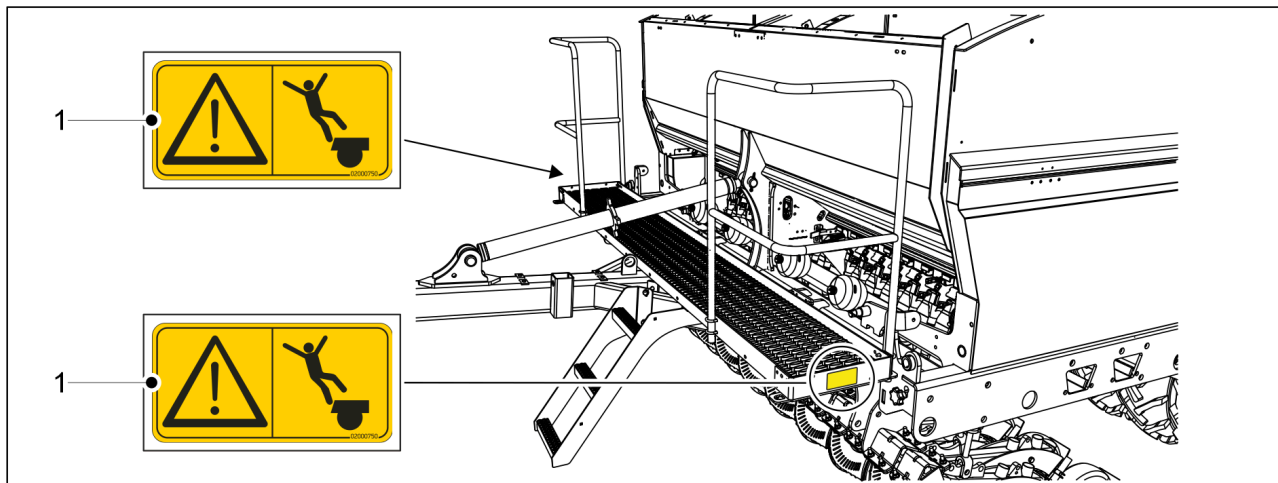

Figure. 3.3 - 9. Front working platform warning labels

Table. 3.3 - 12. Front working platform warning labels

1.	Falling hazard	2 pcs
----	----------------	-------

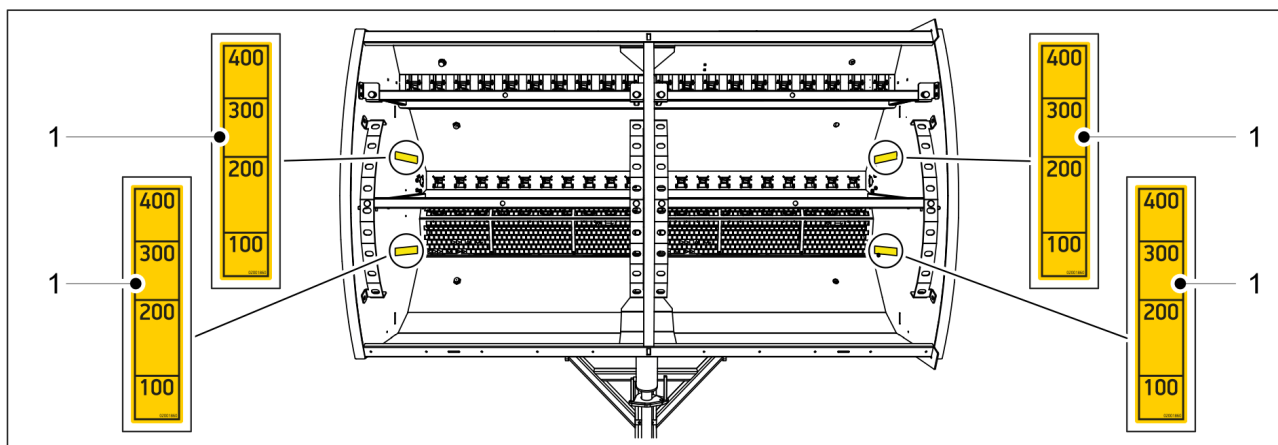

Figure. 3.3 - 10. Labels on the seed drill hopper

Table. 3.3 - 13. Labels on the seed drill hopper

1.	Hopper filling level label (scale 100–400 litres)	2 pcs for fertiliser hopper, 2 pcs for seed hopper
----	---	--

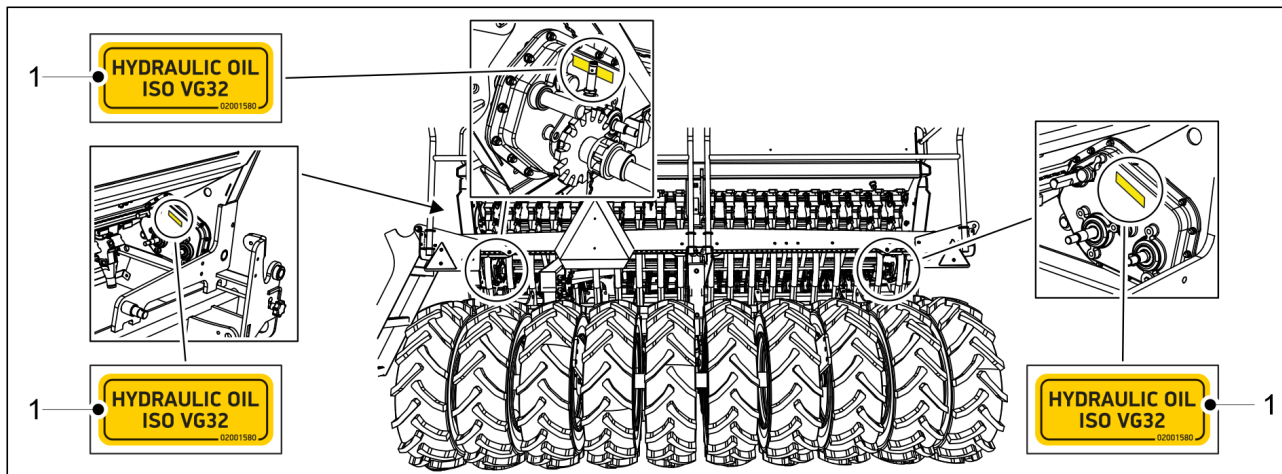

Figure. 3.3 - 11. Gearbox labels

Table. 3.3 - 14. Gearbox labels

1.	Label for gearbox oil to be used	1 pc in each gearbox of the machine
----	----------------------------------	-------------------------------------

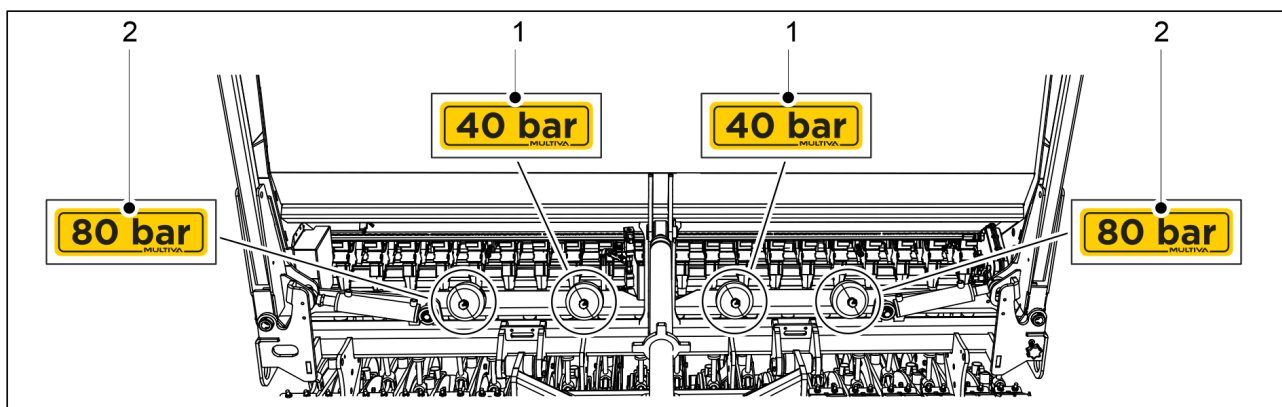

Figure. 3.3 - 12. Pressure accumulator labels

Table. 3.3 - 15. Pressure accumulator labels

1.	Pressure value 40 bar	2 pcs
2.	Pressure value 80 bar	2 pcs

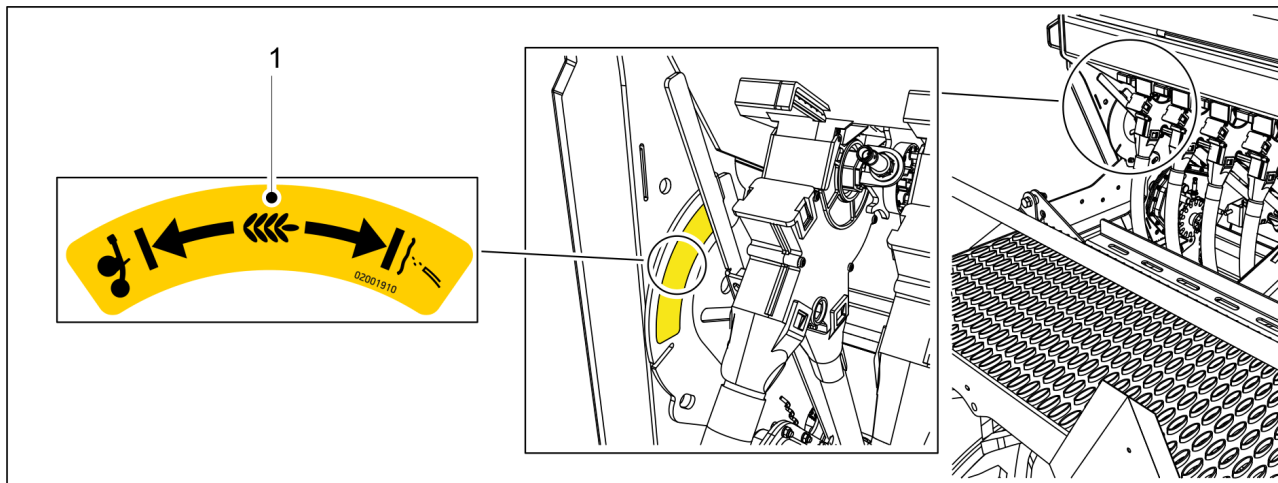

Figure. 3.3 - 13. Instruction label for choosing a small seed sowing method

Table. 3.3 - 16. Instruction label for choosing a small seed sowing method

1.	Instruction label	1 pc
----	-------------------	------

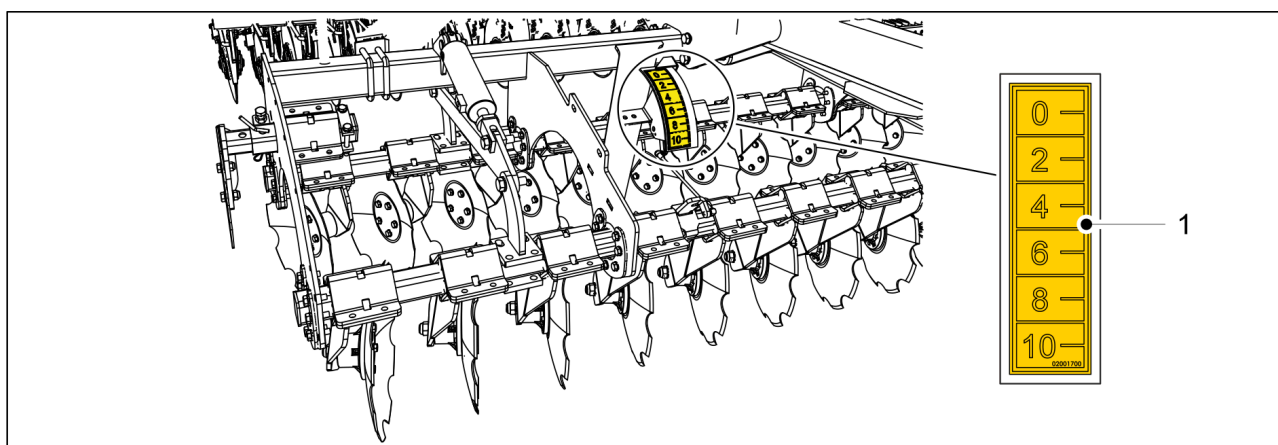

Figure. 3.3 - 14. Front disc cultivator label

Table. 3.3 - 17. Front disc cultivator label

1.	Scale for front disc cultivator depth adjustment	1 pc
----	--	------

3.4 Using the middle marker ball valves



DANGER

There is a crushing and impact hazard when lowering the middle markers.

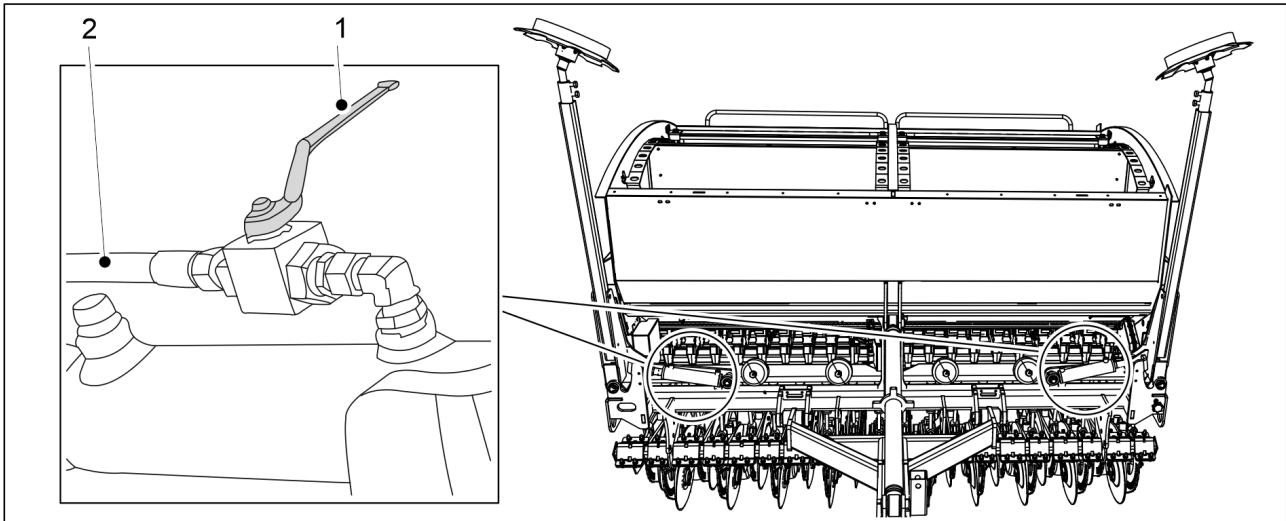

Figure. 3.4 - 15. Closing the middle marker ball valves

1. Close the 2 middle marker ball valves before moving, running a calibration test and servicing.
 - The ball valve is closed when the handle (1) is perpendicular to the hydraulic hose (2).

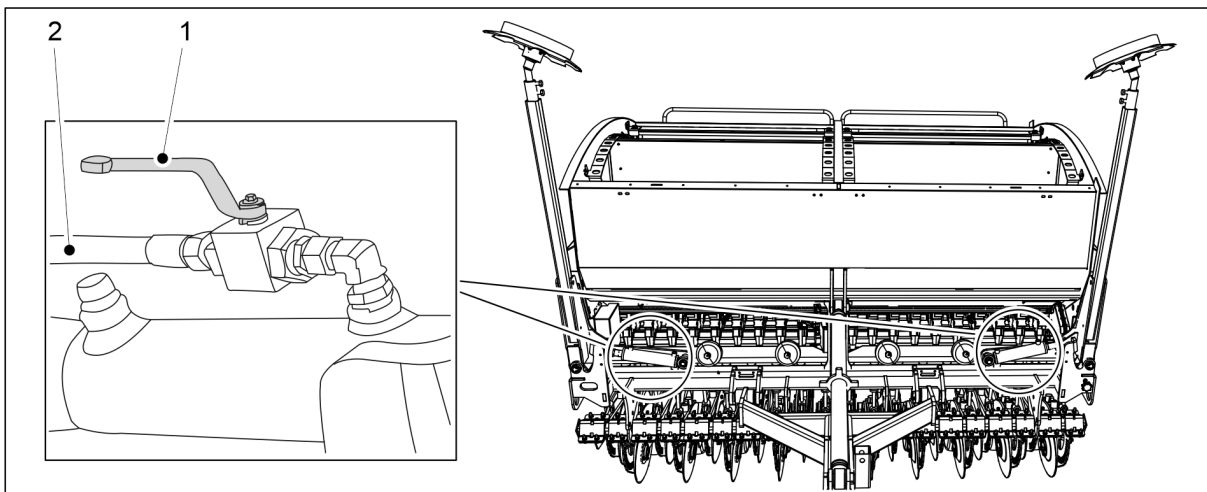

Figure. 3.4 - 16. Opening the middle marker ball valves

2. Open the 2 middle marker ball valves when moving the machine into its working position.
 - The ball valve is open when the handle (1) is in line with the hydraulic hose (2).

4 Controllers

Select one of the following controller types for the seed drill:

- Comfort control system
- SeedPilot control system

These instructions introduce the Comfort control system.

4.1 Comfort control system

4.1.1 Control system components

4.1.1.1 Speed sensor

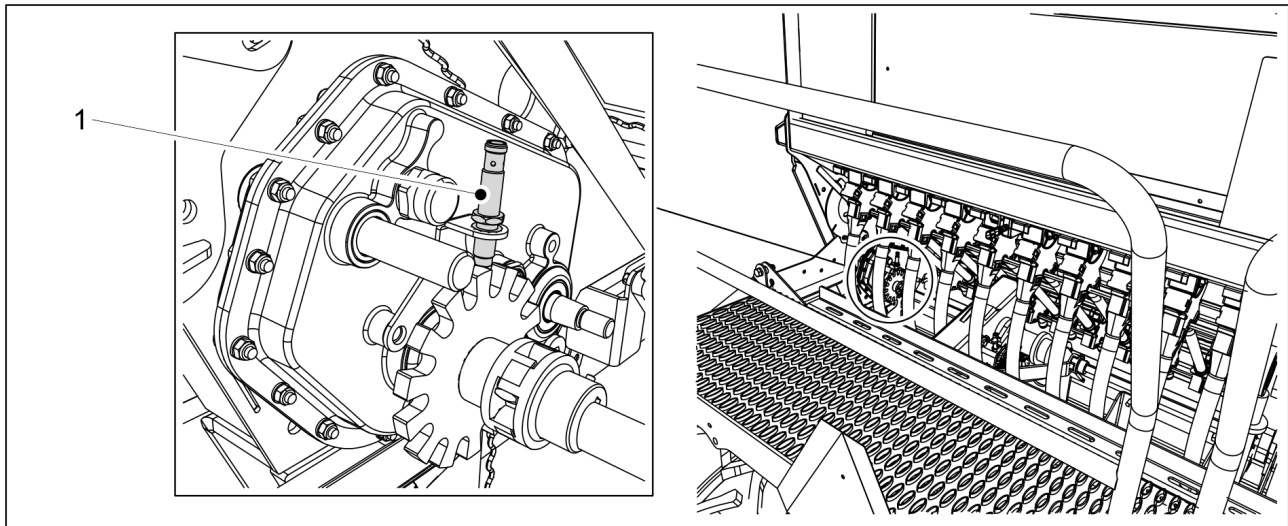

Figure. 4.1.1.1 - 17. Speed sensor

The speed sensor (1) calculates the speed of the seed drill and the area seeded. The Comfort controller system display shows the driving speed and the area seeded. The speed sensor and the seeding position sensor together also indicate that the transmission works. If the machine is in the seeding position and the seed shaft does not rotate, an alarm will be triggered in the controller within 7 seconds.

4.1.1.2 Seeding position sensor

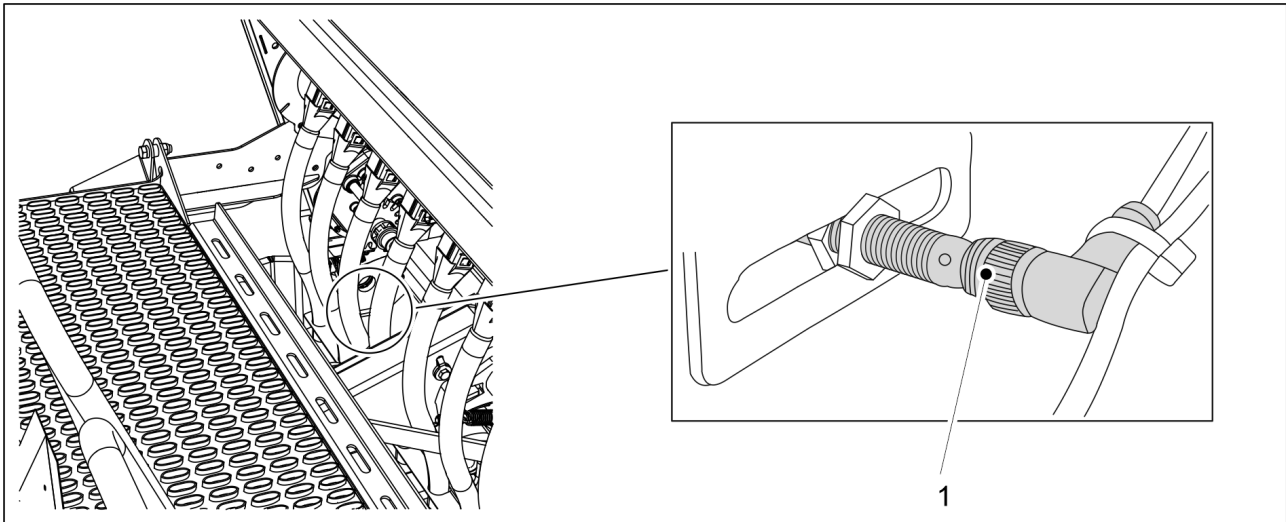

Figure. 4.1.1.2 - 18. Seeding position sensor

The seeding position sensor (1) recognises when the machine is in the transport or seeding position. If the machine is in the seeding position and the seed shaft does not rotate, an alarm will be triggered in the controller within 7 seconds.

The seeding position sensor also works as a counter. In the normal operation of the lift inhibit function, the counters and the marker side switch will be operational whenever lifting. See instruction [6.3.1 Active operating mode](#).

4.1.1.3 Hopper level sensors

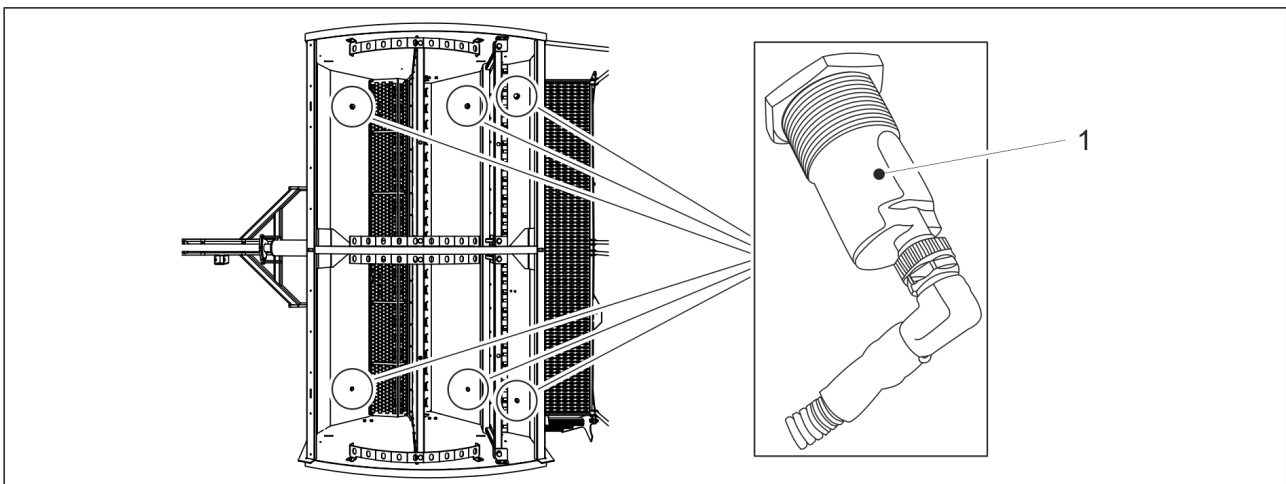

Figure. 4.1.1.3 - 19. Hopper level sensors

The hopper level sensors (1) are capacitive sensors located in the hopper. There are 3 hopper level sensors as a standard feature: one in the seed hopper and one in the small seed hopper on the left side of the machine. Hopper level sensors are also available as an accessory for the right-hand side hoppers of the machine, in which case the total number of hopper level sensors will be 6. If the seed or fertiliser level in the hopper is too low, an alarm is triggered in the Comfort control system.

4.1.1.4 Tramline clutches

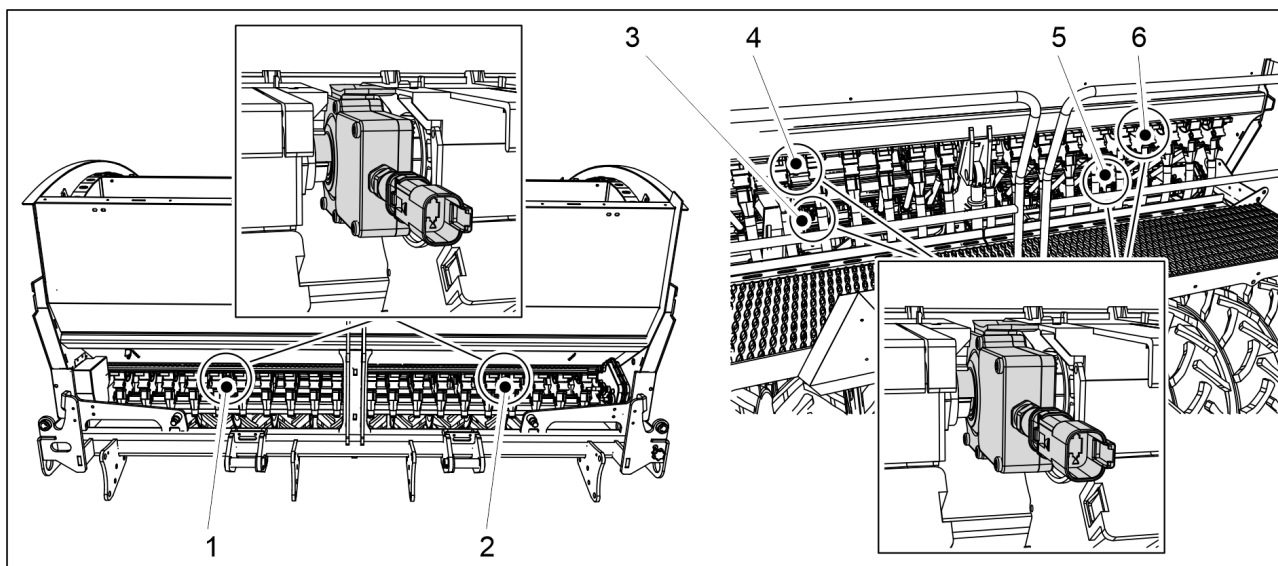

Figure. 4.1.1.4 - 20. Position of the tramline clutches

There are 6 tramline clutches: tramline clutches for fertiliser (1, 2), tramline clutches for seed (3, 5) and tramline clutches a small seed (4, 6).

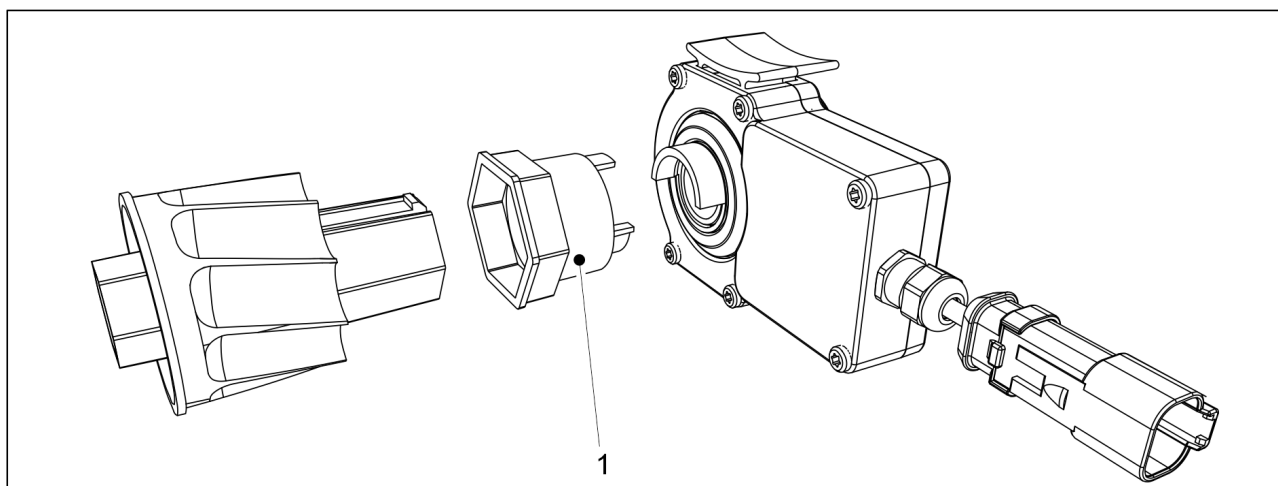

Figure. 4.1.1.4 - 21. Connecting bushing

The tramline clutch has a single feeder connected to the connecting bushing (1) as standard. When the tramline clutch is powered on, the feeder roller of the relevant feeder does not rotate. When seeding, tramlines are created when the leaders connected to the clutches do not sow.

Shaft rotation guards are built into the tramline clutch.

4.1.1.5 Tramline extensions

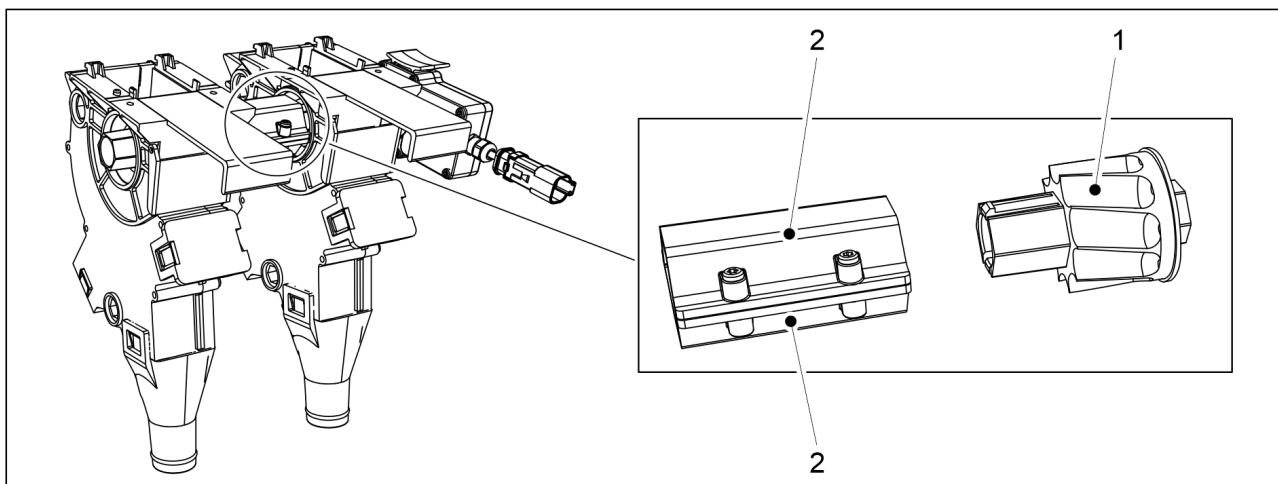

Figure. 4.1.1.5 - 22. Tramline extensions

Each tramline clutch has as standard a single feeder connected, see chapter [4.1.1.4 Tramline clutches](#). The extension pack includes a tramline feeder roller (1) and 2 intermediate bushings (2). The intermediate bushings are connected between the tramline feeder rollers. When the tramline clutches are powered, the feeders connected to the clutches do not rotate.

4.1.1.6 Linear actuator for target rate

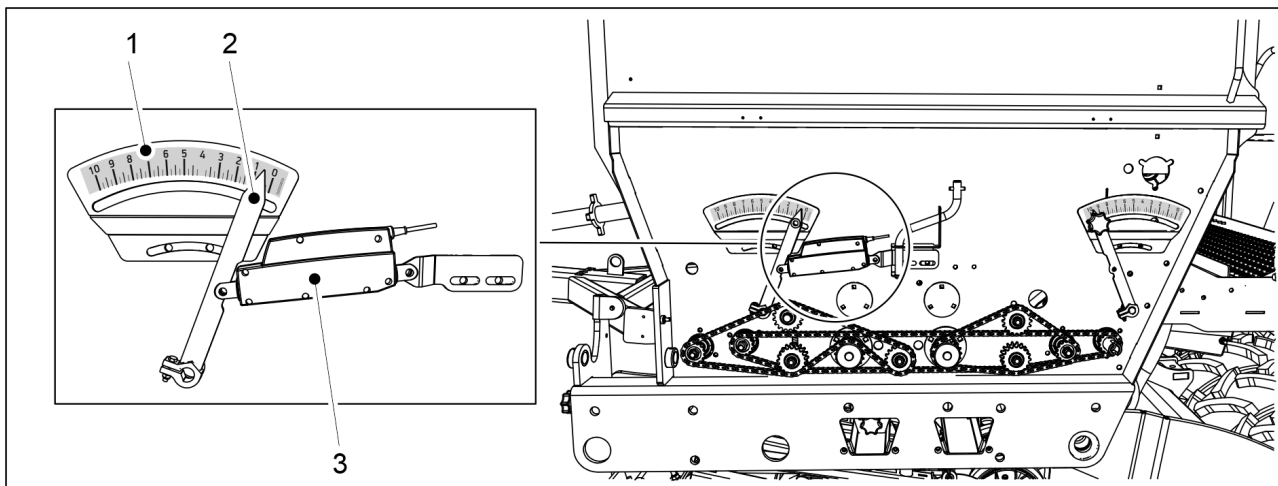

Figure. 4.1.1.6 - 23. Linear actuator for target rate

Linear LINAK actuator (3) is used for fertiliser target rate. A pointer (2) indicates the fertiliser feed rate on a scale of (1). The feed rate scale on the linear actuator describes the relative value of the fertiliser feed rate.

4.1.1.7 Coulter pressure gauge

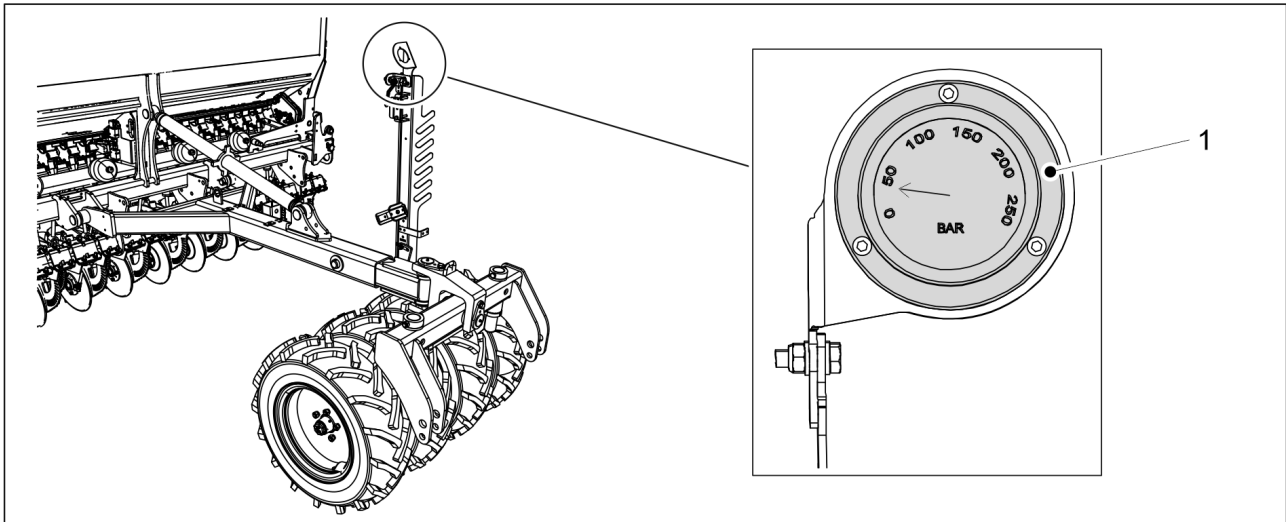

Figure. 4.1.1.7 - 24. Coulter pressure gauge

The coulter pressure gauge (1) is located on the hose rack on top of the wheel packer or on the standard drawbar boom. The coulter pressure gauge measures the coulter pressure.

- The pressure is set between 0 and 150 bar.
0 bar = 50 kg
150 bar = 250 kg

4.1.2 Comfort controller buttons

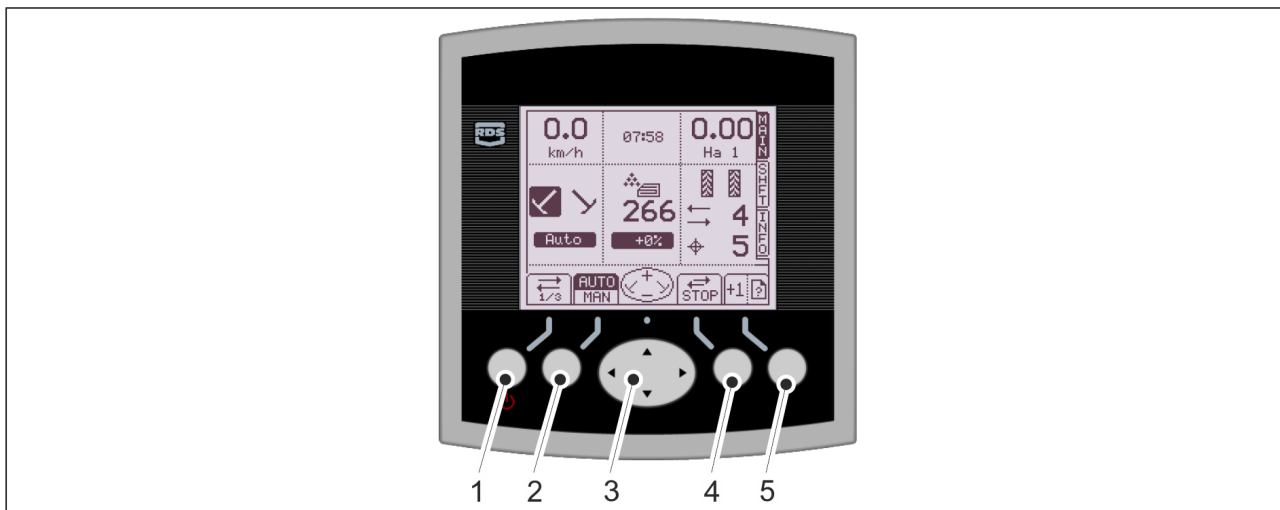

Figure. 4.1.2 - 25. Comfort controller buttons

1.	<p>Switching power on and off</p> <ul style="list-style-type: none"> The controller switches off when the button is held down for 3 seconds. <p>Activating the lift inhibit function</p> <ul style="list-style-type: none"> See instruction 6.3.1 Active operating mode
2.	<p>Selecting the middle marker function</p> <ul style="list-style-type: none"> See instruction 6.3.2 Using middle markers.
3.	<p>Arrow buttons (4): up, down, left and right</p>
4.	<p>Stopping the tramline counter</p> <ul style="list-style-type: none"> See instruction 6.3.3.2 Tramline counter hold.
5.	<p>Changing the page</p> <ul style="list-style-type: none"> When on the MAIN screen of the user interface, go to the next screen (SHFT) by holding down the button for 3 seconds. When on the SHFT, INFO or Setup screen, go to the next screen by pushing the button once. The screen number is shown on the right side of the screen. An icon appears on each screen. <p>Adding a tramline counter</p> <ul style="list-style-type: none"> See instruction 6.3.3.1 Tramline counter correction.

4.1.3 User interface screens

MAIN: the main display

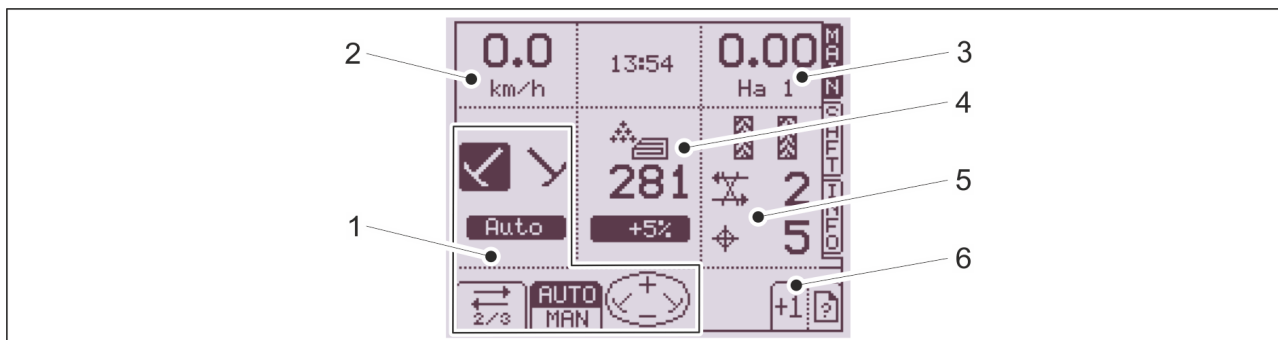

Figure. 4.1.3 - 26. MAIN: the main display

1.	Active position and operation of the middle markers <ul style="list-style-type: none"> • See instruction 6.3.2 Using middle markers
2.	Driving speed
3.	Value of active area measurement
4.	Adjusting of fertiliser target rate
5.	State and counter of tramline clutches <ul style="list-style-type: none"> • See instruction 6.3.3 Using the tramline counter
6.	User interface screen number

SHFT: adjustment and rotation tab

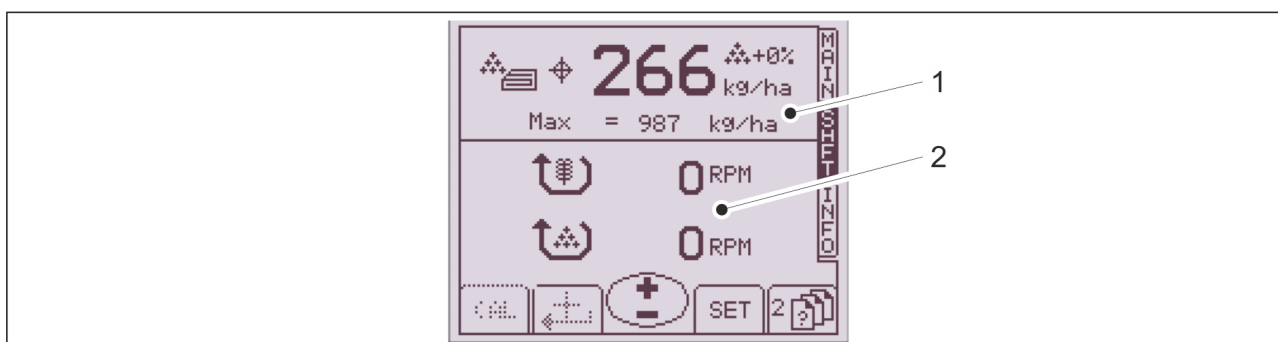

Figure. 4.1.3 - 27. SHFT: adjustment and rotation tab

1.	Adjusting of fertiliser target rate settings <ul style="list-style-type: none"> • See instruction 6.3.5 Selecting the remote control mode
2.	Rotation speed of seed and fertiliser feed shafts

INFO: counter tab

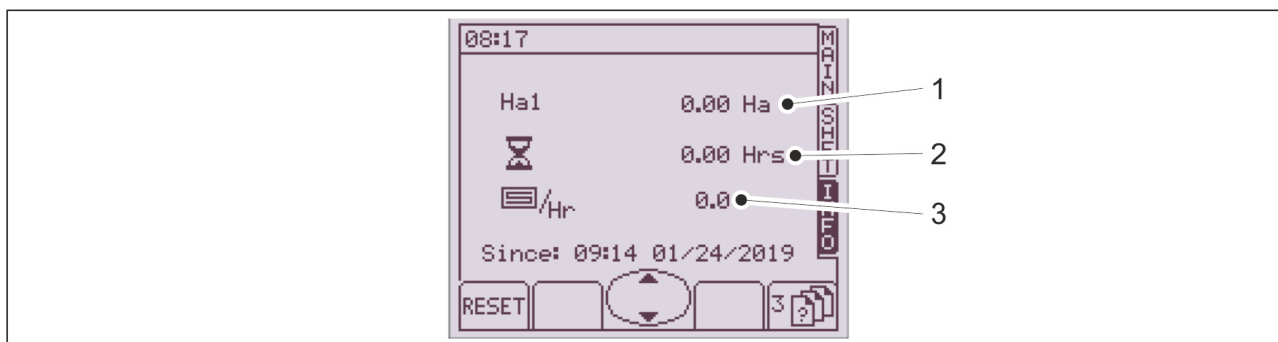

Figure. 4.1.3 - 28. INFO: counter tab

1.	Total area sown
2.	Work time
3.	Average work performed

- Instructions on use of the area counter use can be found in section [6.3.6 Using the area counters](#).

Setup display



Figure. 4.1.3 - 29. Setup display

1.	Product calibration
2.	User setup
3.	Factory settings
4.	Diagnostics

4.1.4 Using the user interface

- If you start the control system when the machine is in its working position, lift and lower the machine using the tractor's hydraulics before starting/resuming work. This will ensure that the user settings are implemented.

4.1.4.1 User setup

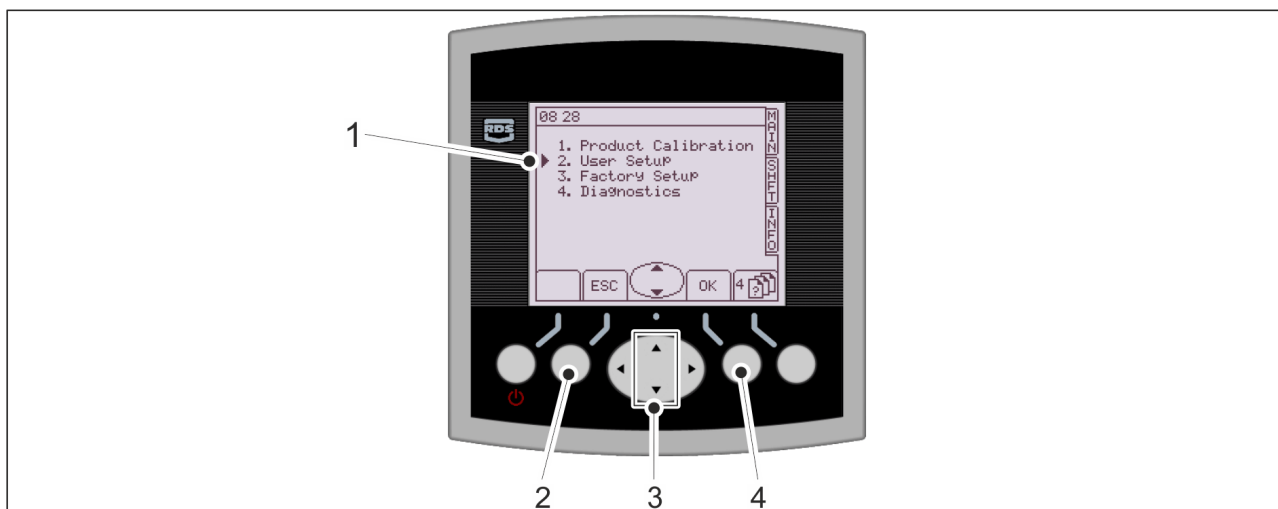

Figure. 4.1.4.1 - 30. User interface Settings screen

- Use the up/down arrow buttons to scroll through the menu. Press the ESC key (2) to return to the previous screen.

1. Move the cursor to User setup (1) and open the screen by pressing the OK key (4).



Figure. 4.1.4.1 - 31. User setup

1.	<p>Display</p> <ul style="list-style-type: none"> • Adjusting the display brightness
2.	<p>Customisation</p> <ul style="list-style-type: none"> • Adjusting the fertiliser target rate step
3.	<p>Time/date</p> <ul style="list-style-type: none"> • Time and date setting

4.	Technical support <ul style="list-style-type: none">• Technical support contact details
5.	Language <ul style="list-style-type: none">• Language selection
6.	Seed drill <ul style="list-style-type: none">• Setting the seed drill parameters
7.	Tramlines <ul style="list-style-type: none">• Tramline setting
8.	Alarms <ul style="list-style-type: none">• Setting alarms

4.1.4.2 Adjusting the fertiliser target rate step



Figure. 4.1.4.2 - 32. Adjusting the fertiliser target rate step

1. Press the OK key (1).
2. Set the new target value using the up/down arrow keys. Confirm the value by pressing the right arrow key.
3. Accept the step value by pressing the OK key (1).

4.1.4.3 Seed drill parameters



Figure. 4.1.4.3 - 33. Seed drill parameters

1.	<p>Seed drill width</p> <ul style="list-style-type: none"> • 3 m or 4 m
2.	<p>Speed sensor</p> <ul style="list-style-type: none"> • The factory setting is 0.214. • See instruction 7.10.1 Manual calibration of the speed sensor.
3.	<p>Speed sensor calibration</p> <ul style="list-style-type: none"> • See instruction 7.10.2 Calibration of the speed sensor while driving.
4.	<p>T Factor</p> <ul style="list-style-type: none"> • Electric fertiliser control calibration value, which varies according to the calibration test result. • Cannot be changed on this screen.

4.1.4.4 Setting the tramline automation

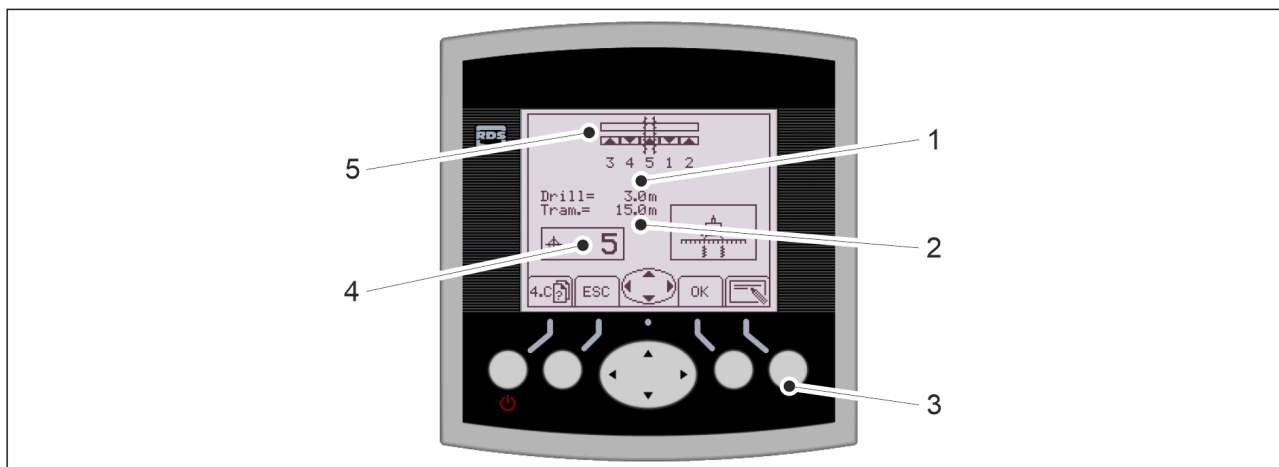

Figure. 4.1.4.4 - 34. Setting tramlines

- The seed drill width (1), the width of the sprayer used (2) and the number of passes (4) are displayed on the screen.
1. Select the number of passes (4) using the up/down arrow buttons.
 - If the machine is to be run without tramlines, select '0' for the number of tramlines. In this case, the tramlines are not used, but the middle markers will switch sides.
 2. Select the position of the tramlines using the (5) left/right arrow keys.

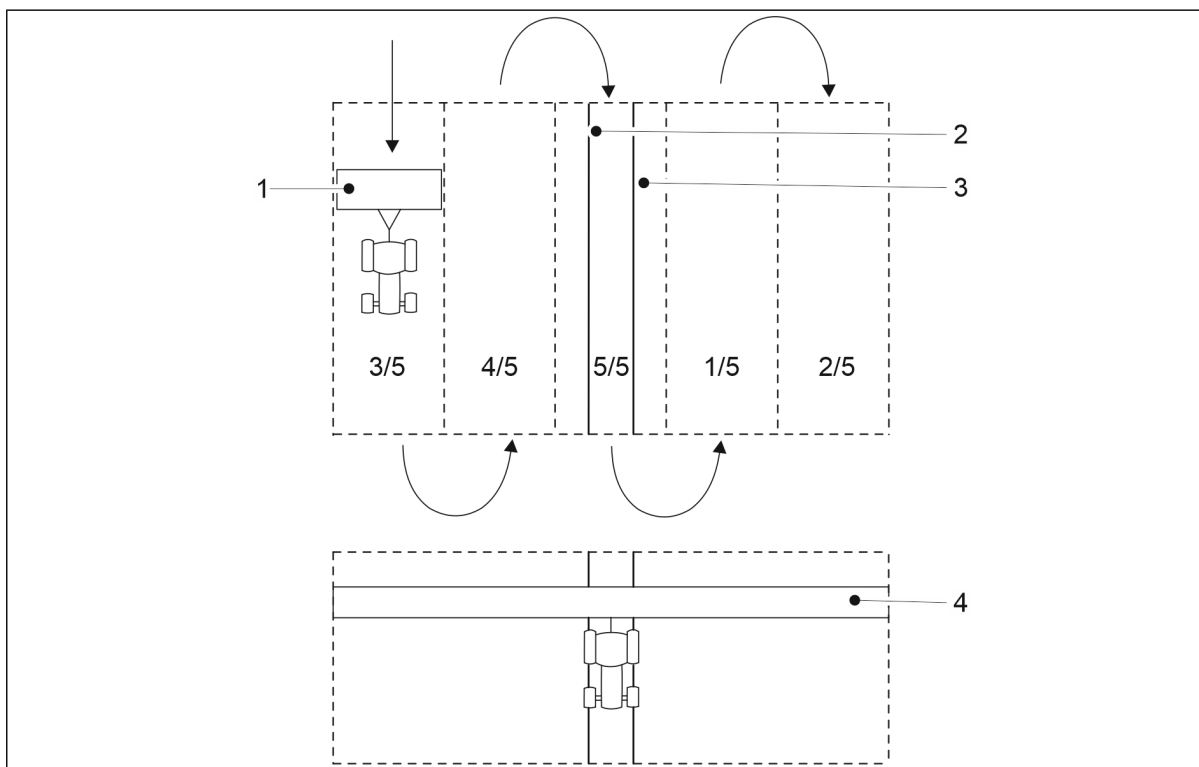

Figure. 4.1.4.4 - 35. Tramlines

- The width of the pass is the same as the width of the seed drill (1). In this case, the width of the seed drill is 3 m and there are 5 passes, so the width of the sprayer (4) is 15 m. The tramlines (2, 3) are made on the 5th pass.

4.1.4.5 Setting alarms

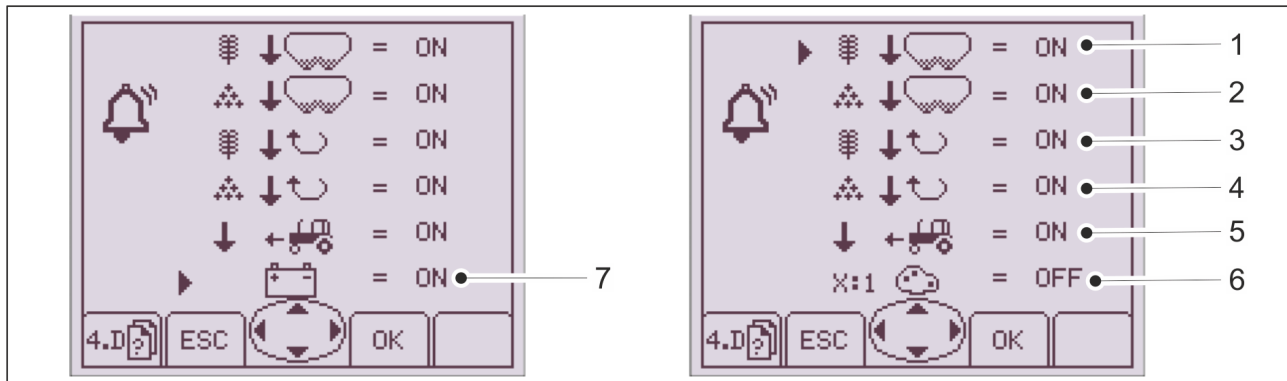

Figure. 4.1.4.5 - 36. Alarms

1.	Seed hopper level sensor <ul style="list-style-type: none"> • The alarm is triggered when the seed hopper is empty.
2.	Fertiliser hopper level sensor <ul style="list-style-type: none"> • The alarm is triggered when the fertiliser hopper is empty.
3.	Shaft rotation guard - seed <ul style="list-style-type: none"> • The alarm is triggered when the shaft stops but the transmission keeps running.
4.	Shaft rotation guard - fertiliser <ul style="list-style-type: none"> • The alarm is triggered when the shaft stops but the transmission keeps running.
5.	Tractor speed <ul style="list-style-type: none"> • The alarm is triggered when the seed drill is in the working position and the tractor is not moving. The driving speed begins to flash on the MAIN screen.
6.	X:1 <ul style="list-style-type: none"> • Disabled. The alarm is not activated.
7.	Voltage <ul style="list-style-type: none"> • The alarm is triggered when the voltage falls below 9 V.



Figure. 4.1.4.5 - 37. Selecting alarms

- Use the up/down arrow buttons to scroll through the menu.
1. Enable or disable the alarm with the right arrow key.
 2. Confirm the selection by pressing the OK button (1).

5 Commissioning and basic settings

5.1 Rendering to operating condition

5.1.1 Mounting the wheel packer



DANGER

The mounting of the wheel packer requires two people.



DANGER

Use a hoisting accessory when mounting the wheel packer.



DANGER

Lift and mount the wheel packer only when the machine is on a level surface.

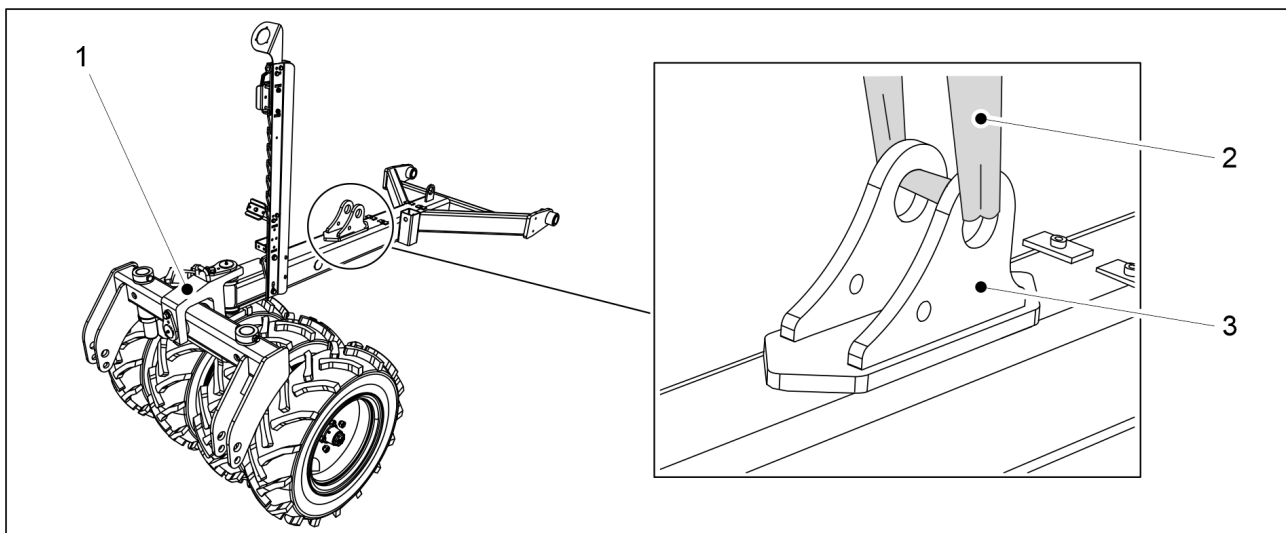

Figure. 5.1.1 - 38. Lifting the wheel packer

1. Place the wheel packer (1) to the centreline and to the front of the machine and attach the lifting sling (1) to the cylinder bracket (3).



DANGER

Ensure that the capacity of the lifting sling and the lifting device is sufficient. The wheel packer weighs 250 kg.

2. Lift the bar and align it with the attachment points.

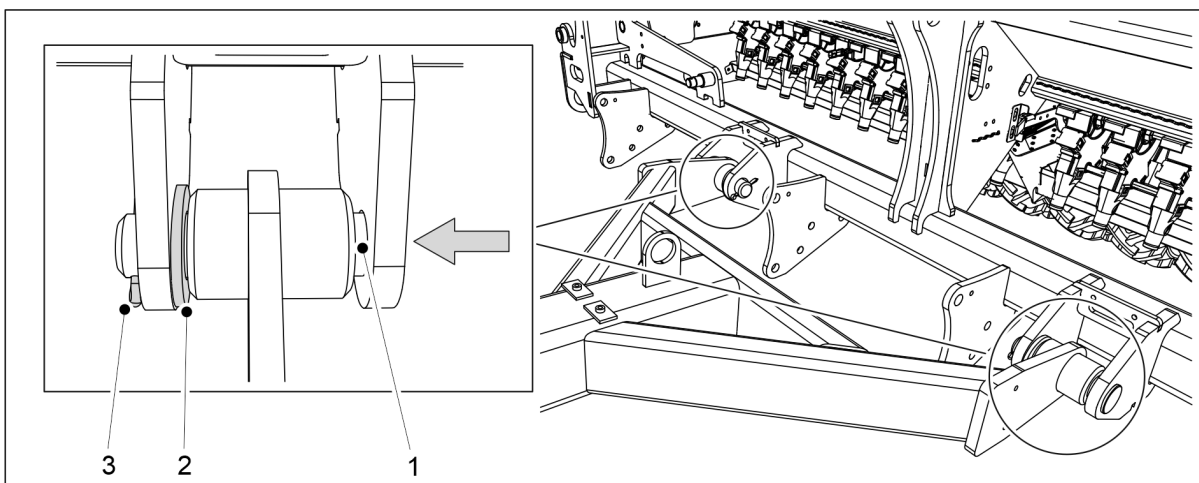

Figure. 5.1.1 - 39. Mounting the wheel packer

3. Place the washer (2) against the inner shoulder of the attachment points and insert the mounting pin (1) through the shoulders and the mounting cylinder of the bar.
4. Lock the mounting pin in place with a spring cotter (3).
5. Repeat steps 3-4 for the second attachment point.

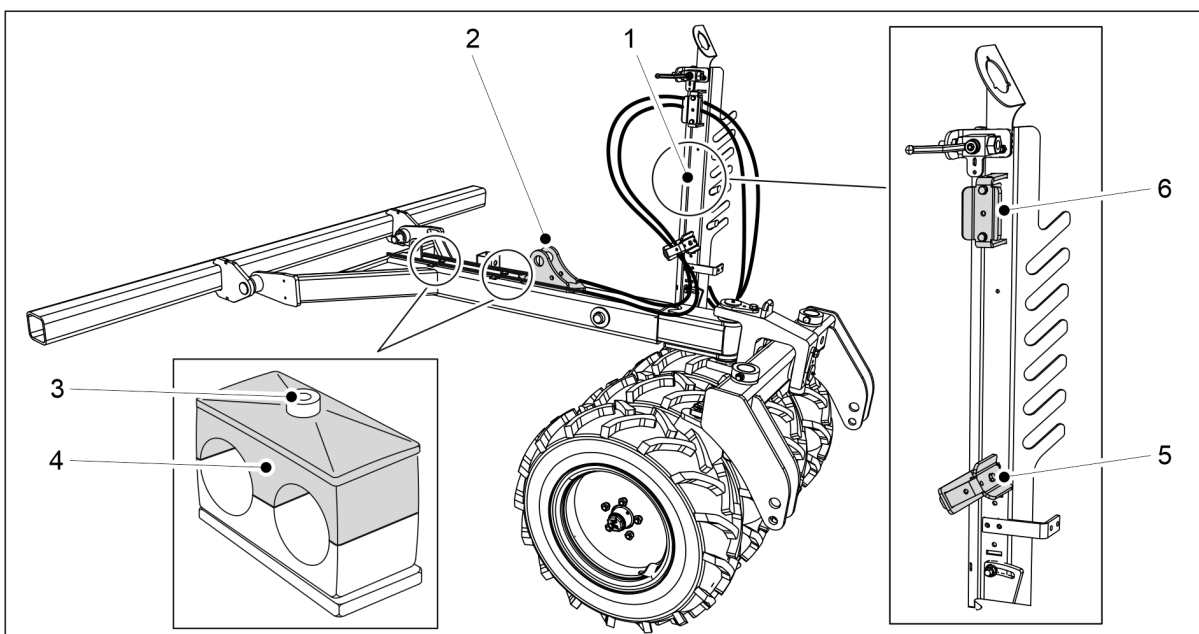

Figure. 5.1.1 - 40. Hydraulic hoses and electrical wires

6. Open the fastening screw (3) of the tube mounts and remove the top (4).
7. Pull the hydraulic hoses on both sides of the cylinder bracket (2) into the hose clamps (5, 6) of the hose rack (1).
8. Use cable ties to fasten the hoses on both sides of the cylinder bracket.
 - Do not tighten the cable ties to the final tightness.
9. Place the hoses in the tube mounts and fasten the top of the tube mounts and the fastening screws.

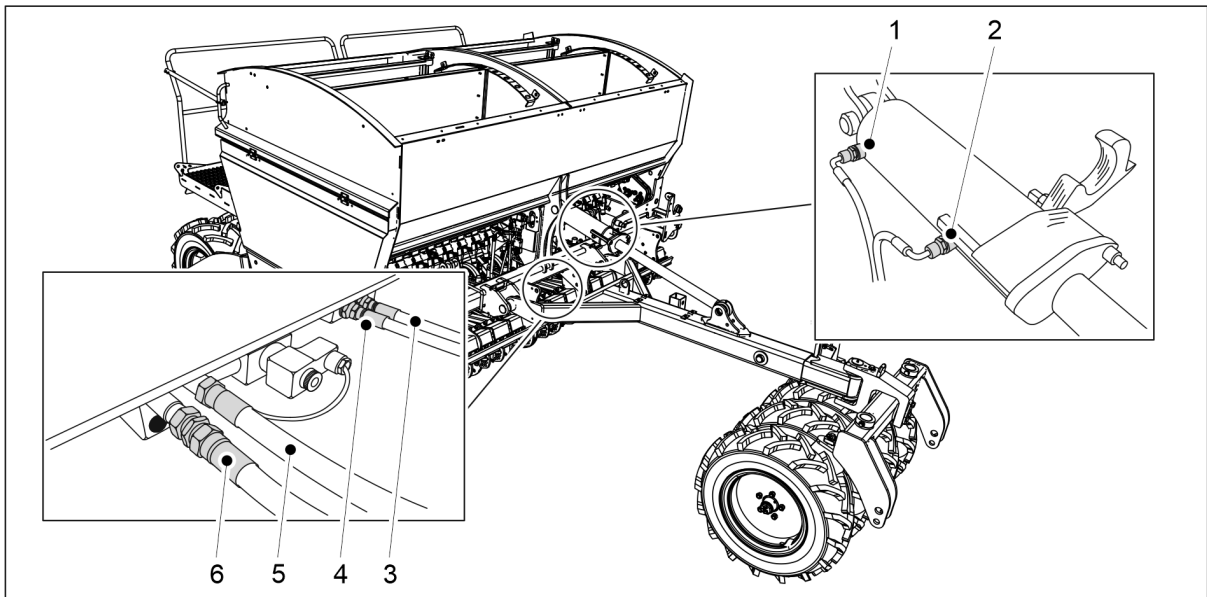

Figure. 5.1.1 - 41. Connecting the hydraulic hoses

1.	Green, one mark	Drawbar cylinder, cylinder extend
2.	Green, two marks	Drawbar cylinder, cylinder retract
3.	Blue, one mark	Coulter pressure, decreasing the coulter pressure
4.	Blue, two marks	Coulter pressure, increasing the coulter pressure
5.	Red, one mark	Lifting the seed drill
6.	Red, two marks	Lowering the seed drill

10. Connect the hydraulic hoses 3-6.
 - Connect the hydraulic hoses of the drawbar cylinder only when the drawbar cylinder is installed.
11. Push the hoses back towards the drawbar to eliminate slack and tighten the tube mounts and cable ties.
12. Attach the electrical wires contained in a protective tube to the hydraulic hoses with cable ties and guide the wires on the right side of the seed drill (viewed from the front).
13. Install the drawbar in accordance with section [5.1.2 Mounting the drawbar cylinder](#).

5.1.2 Mounting the drawbar cylinder

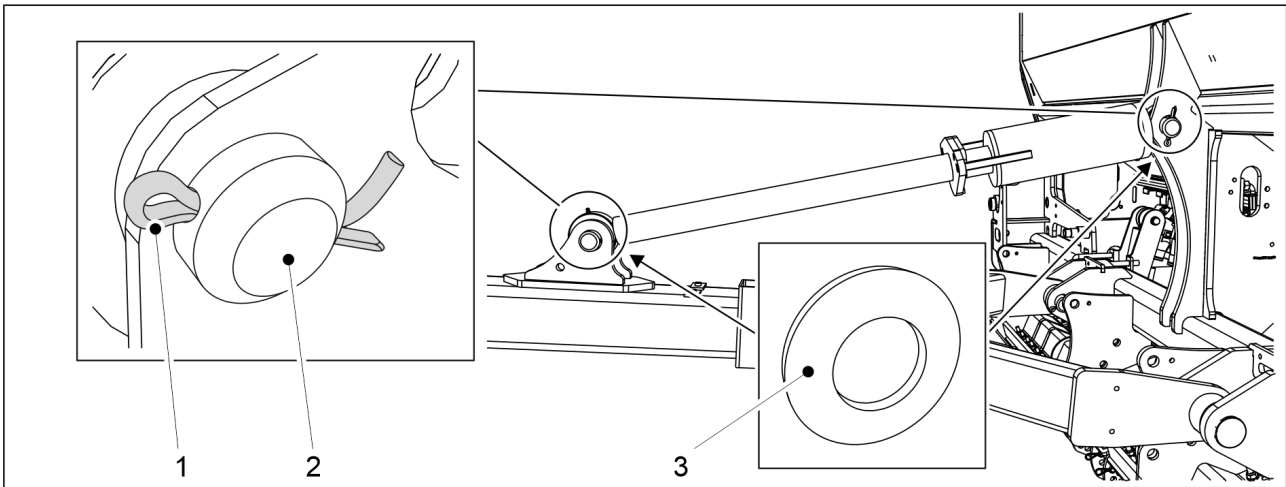

Figure. 5.1.2 - 42. Drawbar cylinder

Number	Component	Quantity
1.	Locking pin Ø8x71	2 pcs
2.	Pin Ø45x110	2 pcs
3.	Washer M45	4 pcs

1. Replace the washer (3) and fasten the drawbar cylinder to the seed drill with a mounting pin (2).
2. Lock the mounting pin in place with the cotter (1).
3. Repeat steps 1-2 for the second attachment point of the cylinder.

5.1.3 Attaching the turnbuckle

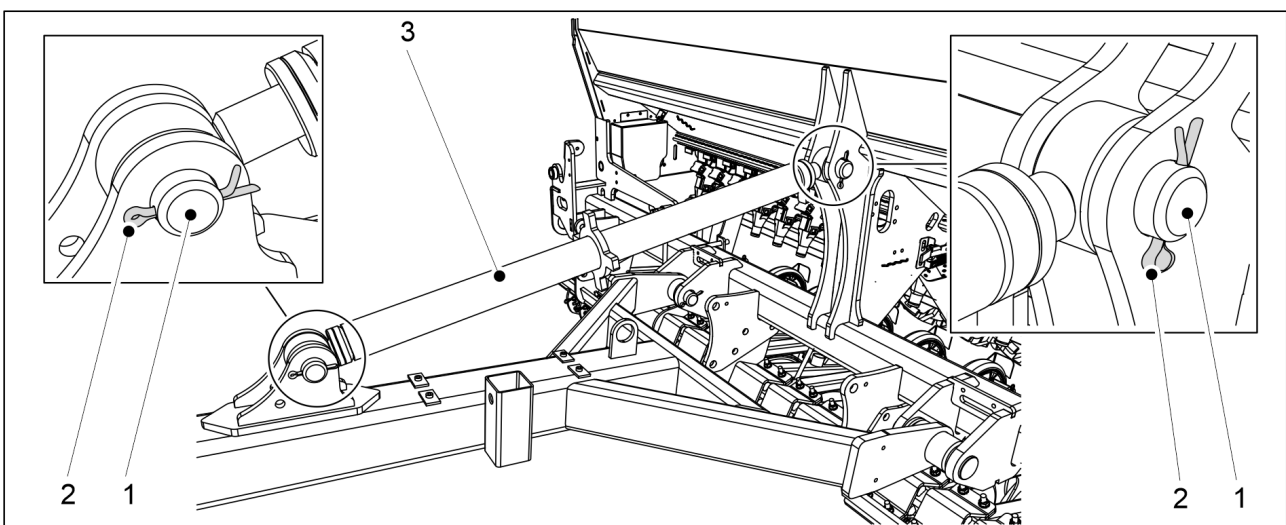

Figure. 5.1.3 - 43. Turnbuckle

Number	Component	Quantity
1.	Pin Ø45x110	2 pcs
2.	Locking pin Ø8x71	2 pcs

1. Attach the turnbuckle (3) to the seed drill with the mounting pin (1)
2. Lock the mounting pin in place with the cotter (2).
3. Repeat steps 1-2 for the second attachment point of the turnbuckle.

5.1.4 Mounting the front levelling board

- Using the front levelling board requires that a wheel packer be installed.



DANGER

The mounting of the front levelling board requires two people.



DANGER

Use a hoisting accessory when mounting the front levelling board.

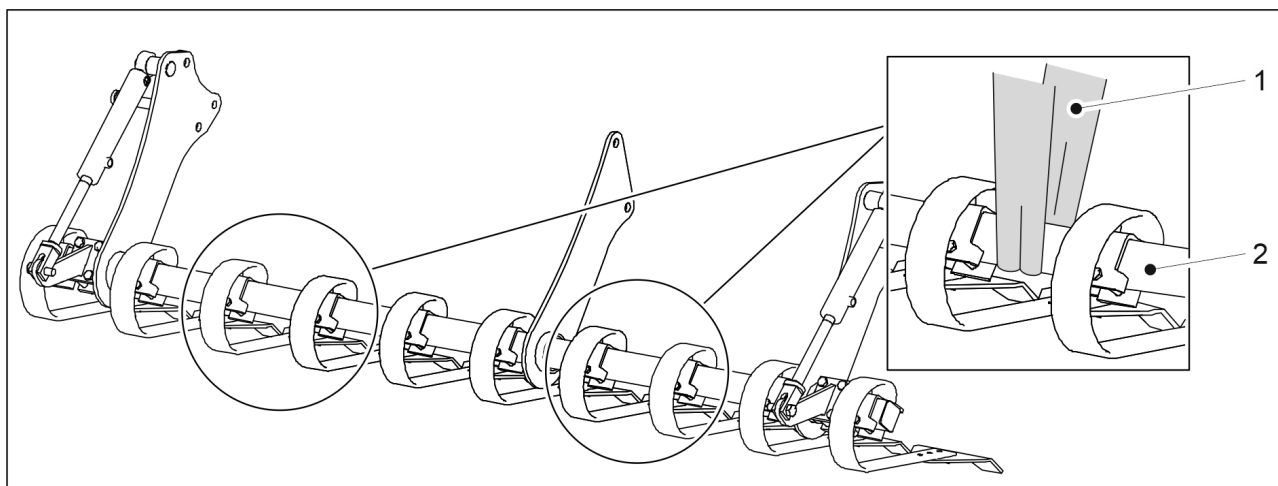

Figure. 5.1.4 - 44. Lifting the front levelling board

1. Fasten lifting slings (1) around the tube (2).



DANGER

Ensure that the capacity of the lifting sling and the lifting device is sufficient. The front levelling board weighs 250 kg.

2. Follow the mounting instructions for the FORTE 300 EVO- or FORTE 400 EVO .

Mounting the front levelling board on a FORTE 300 EVO

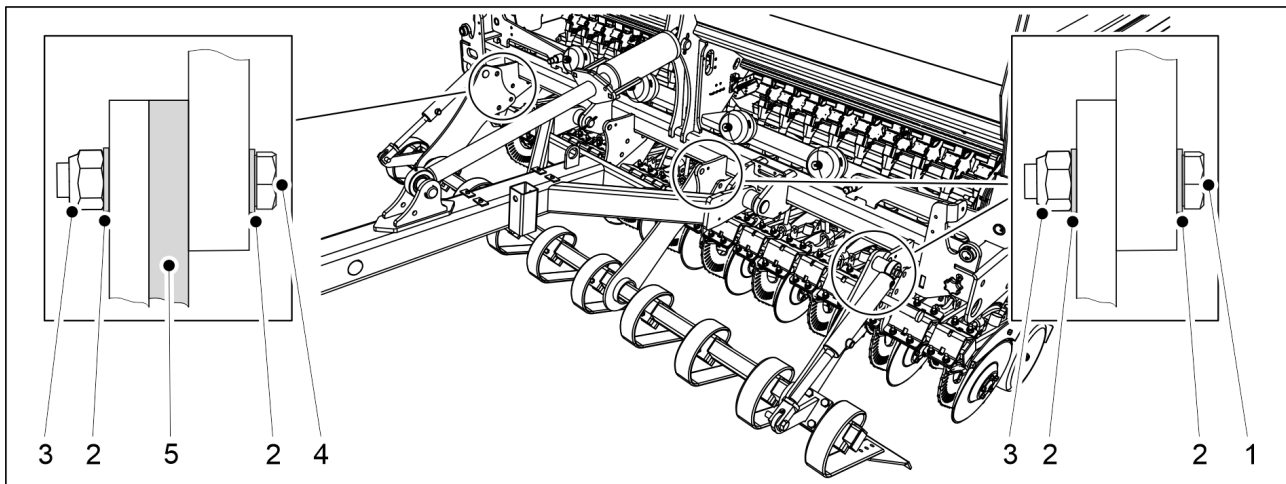

Figure. 5.1.4 - 45. Mounting the front levelling board on a FORTE 300 EVO

Number	Component	Quantity
1.	Hex screw M24x60	5 pcs
2.	Washer M24	16 pcs
3.	Locking nut M24	8 pcs
4.	Hex screw M24x75	3 pcs
5.	Shim	1 pcs

1. Raise the front levelling board using lifting slings and push it under the wheel packer drawbar to the body of the machine.
2. Attach the front levelling board to the machine body with components (1-5).
 - The front levelling board is fastened to the machine body at three fastening points. Place a shim between the front levelling board and machine body at the fastening point on the left side of the machine (looking from the front).

Mounting the front levelling board on a FORTE 400 EVO

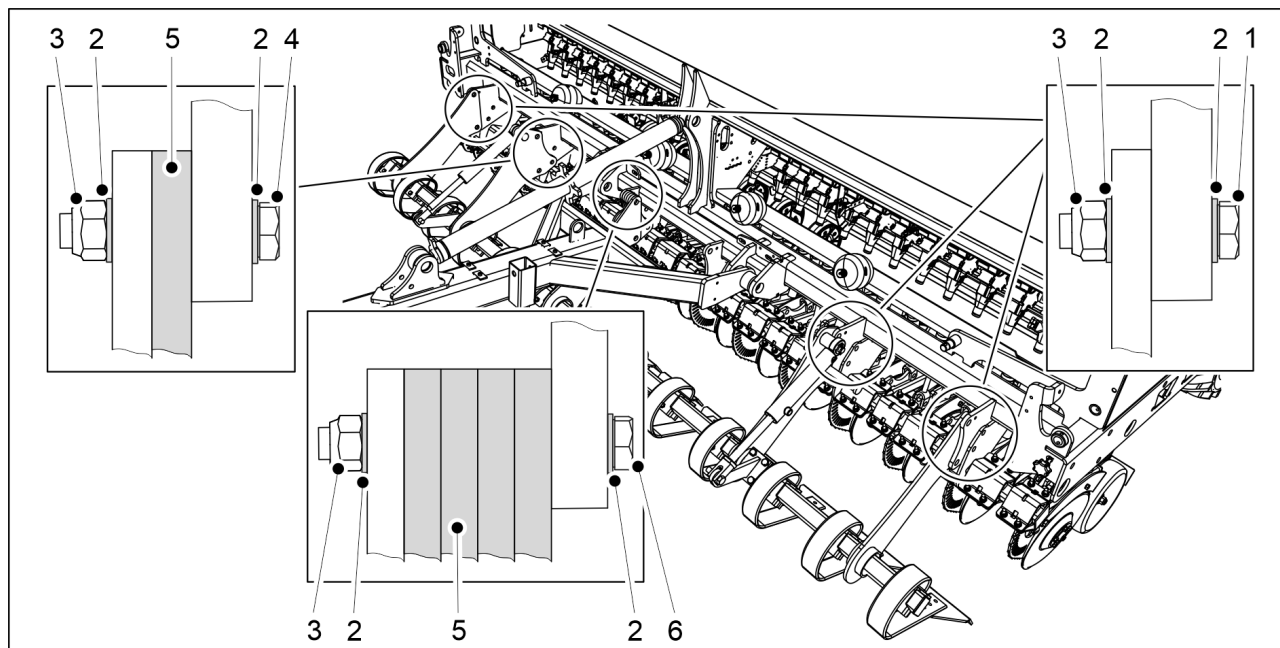

Figure. 5.1.4 - 46. Mounting the front levelling board on a FORTE 400 EVO

Number	Component	Quantity
1.	Hex screw M24x60	7 pcs
2.	Washer M24	26 pcs
3.	Locking nut M24	13 pcs
4.	Hex screw M24x75	3 pcs
5.	Shim	5 pcs
6.	Hex screw M24x120	3 pcs

1. Raise the front levelling board using lifting slings and push it under the wheel packer drawbar to the body of the machine.
2. Attach the front levelling board to the machine body with components (1-6).
 - The front levelling board is fastened to the machine body at five fastening points. Place a shim between the front levelling board and machine body at the second fastening point on the left side of the machine (looking from the left side). Place 4 shims between the front levelling board and machine body at the centremost fastening point.

5.1.5 Mounting the front harrow



DANGER

The mounting of the front harrow requires two people.



DANGER
 Use a hoisting accessory when mounting the front harrow.

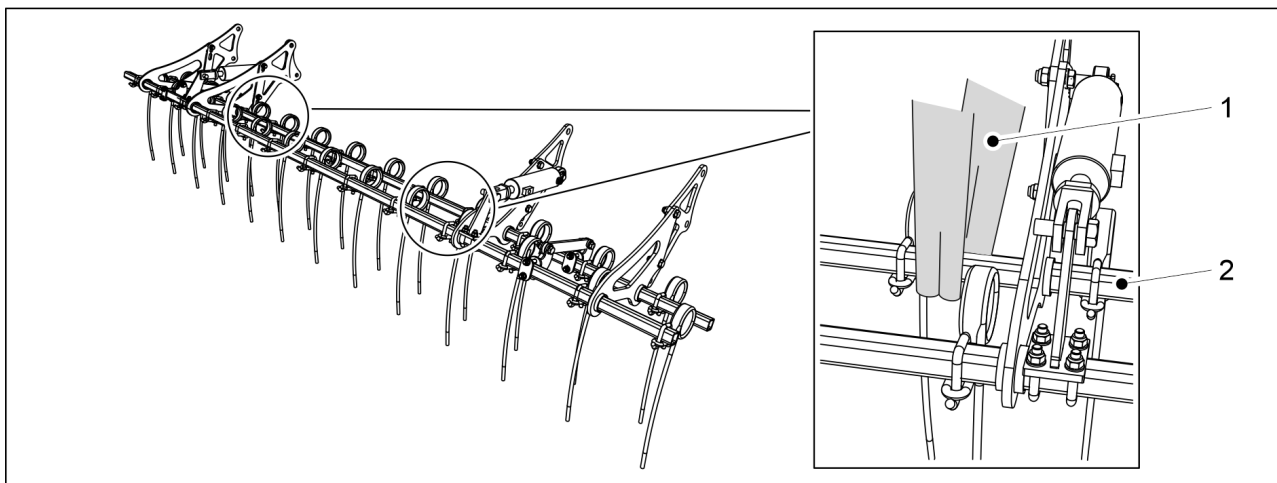

Figure. 5.1.5 - 47. Lifting the front harrow

1. Fasten lifting slings (1) around the tube (2).



DANGER
 Ensure that the capacity of the lifting sling and the lifting device is sufficient.
 FORTE 300 EVO: The front harrow weighs 140 kg. FORTE 400 EVO: The front harrow weighs 160 kg.

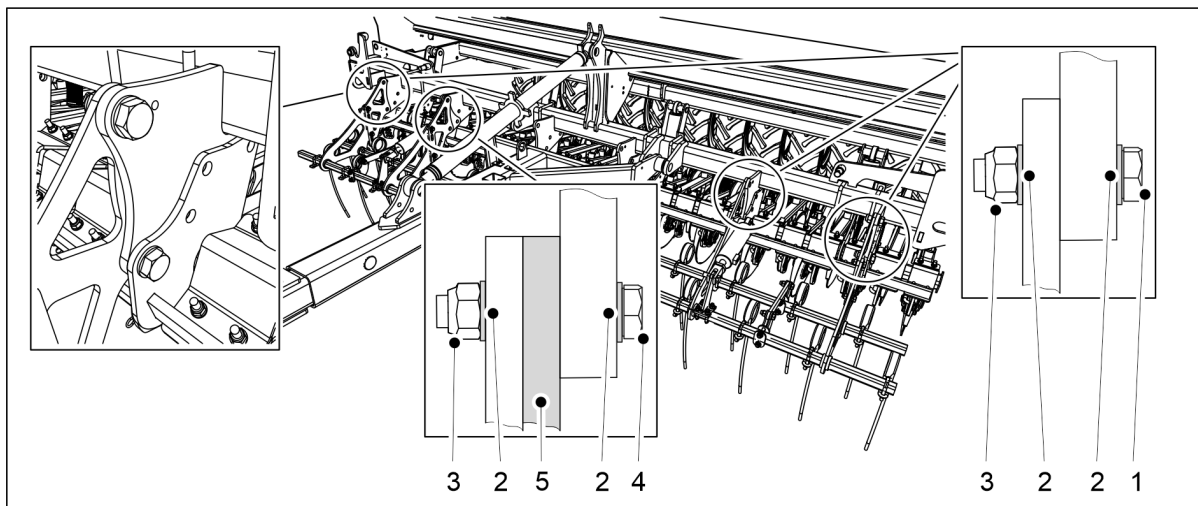

Figure. 5.1.5 - 48. Mounting the front harrow

Number	Component	Quantity
1.	Hex screw M24x60	6 pcs
2.	Washer M24	16 pcs
3.	Locking nut M24	16 pcs
4.	Hex screw M24x75	2 pcs
5.	Shim	1 pcs

2. Raise the front harrow using lifting slings and push it under the wheel packer drawbar all the way to the machine frame.
3. Attach the front harrow to the machine frame using components (1-5).
 - The front harrow is mounted to the frame at 4 mounting points. Place a shim between the front harrow and the machine frame at the other mounting point on the left (as seen from the front of the machine).

5.1.6 Mounting the front disc cultivator

- Using the front disc cultivator requires the installation of a wheel packer.



DANGER

Mounting the front disc cultivator requires two people.



DANGER

Use a hoisting accessory when mounting the front disc cultivator.

1. Set the front disc cultivator in front of the seed drill.

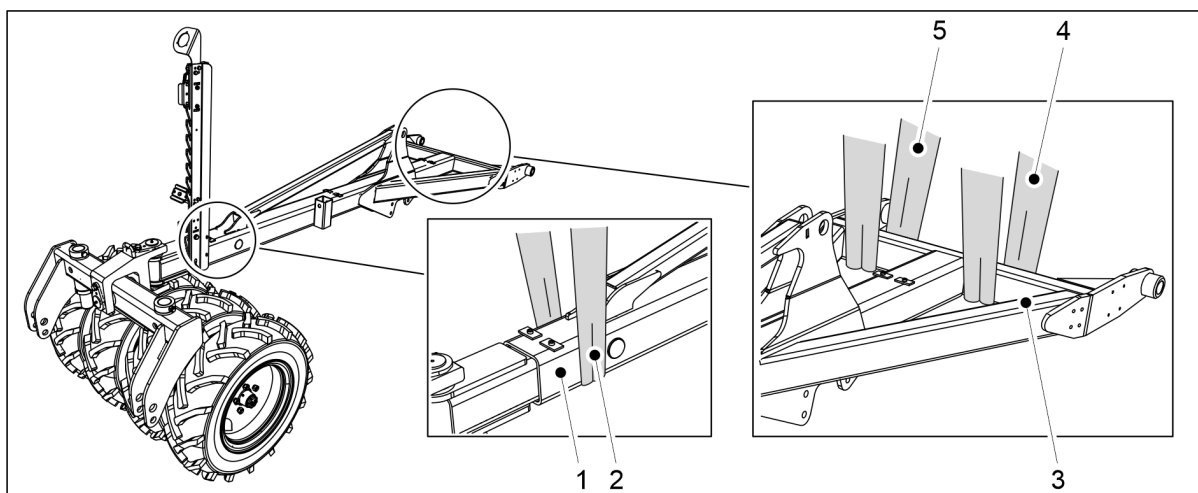

Figure. 5.1.6 - 49. Drawbar and wheel packer

2. Fasten a lifting sling (2) to the drawbar (1) close to the wheel packer and lifting slings (4, 5) to the cross-members of the drawbar (3).



DANGER

Ensure that the capacity of the lifting sling and the lifting device is sufficient. The drawbar mass (including the wheel packer) is 500 kg.

3. Lift the drawbar over the front disc cultivator.

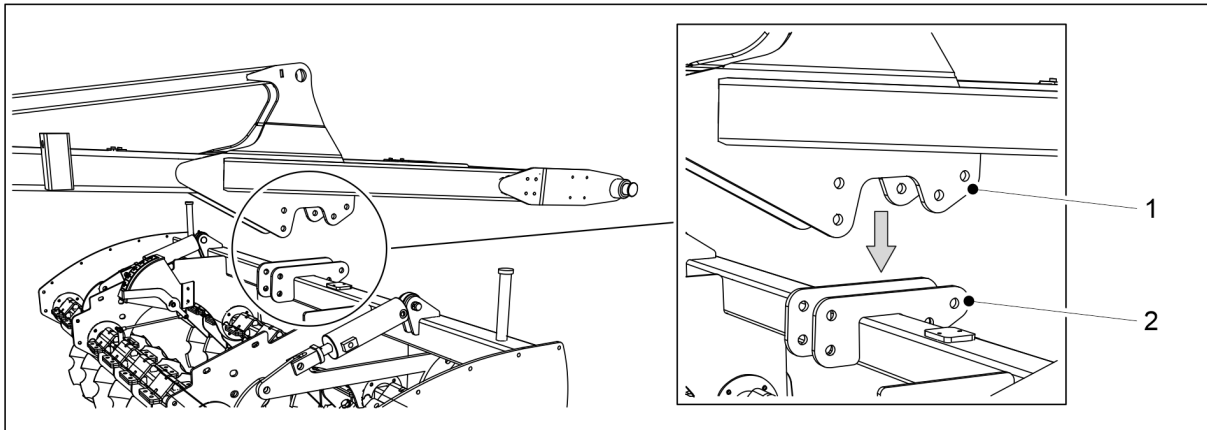

Figure. 5.1.6 - 50. Placement of the drawbar on the front disc cultivator

4. Lower the drawbar so that its middle brackets (1) line up with the mounting brackets (2) on the horizontal beam of the front disc cultivator (2).

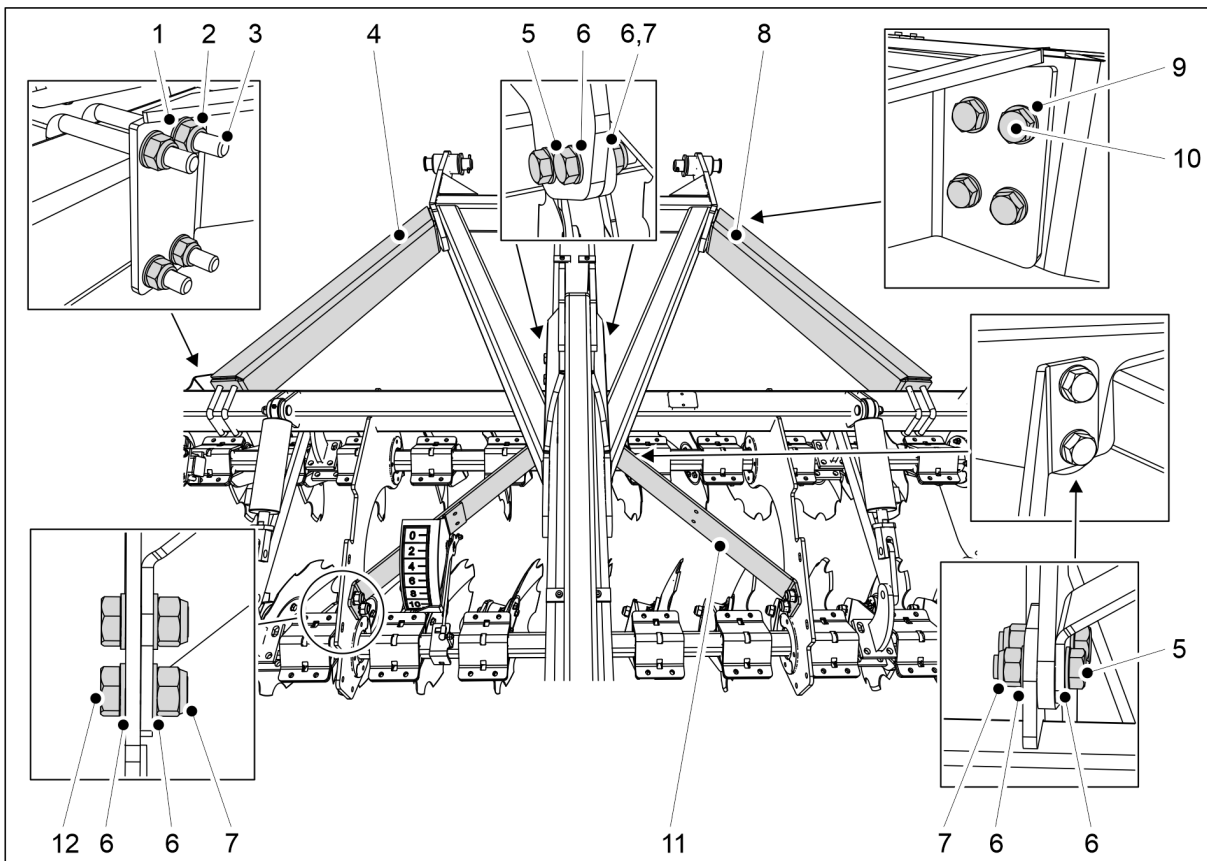

Figure. 5.1.6 - 51. Attaching the front disc cultivator to the drawbar

Number	Component	Quantity
1.	Washer M16	8 pcs
2.	Locking nut M16	8 pcs
3.	U-bolt M16 100x100	4 pcs
4.	Support iron	1 pcs
5.	Hex screw M20x65	8 pcs

6.	Washer M20	24 pcs
7.	Locking nut M20	12 pcs
8.	Support iron	1 pcs
9.	Washer M12	8 pcs
10.	Hex screw M12x45	8 pcs
11.	Support iron	2 pcs
12.	Hex screw M20x45	4 pcs

5. Attach the front disc cultivator to the drawbar with components (1-12).

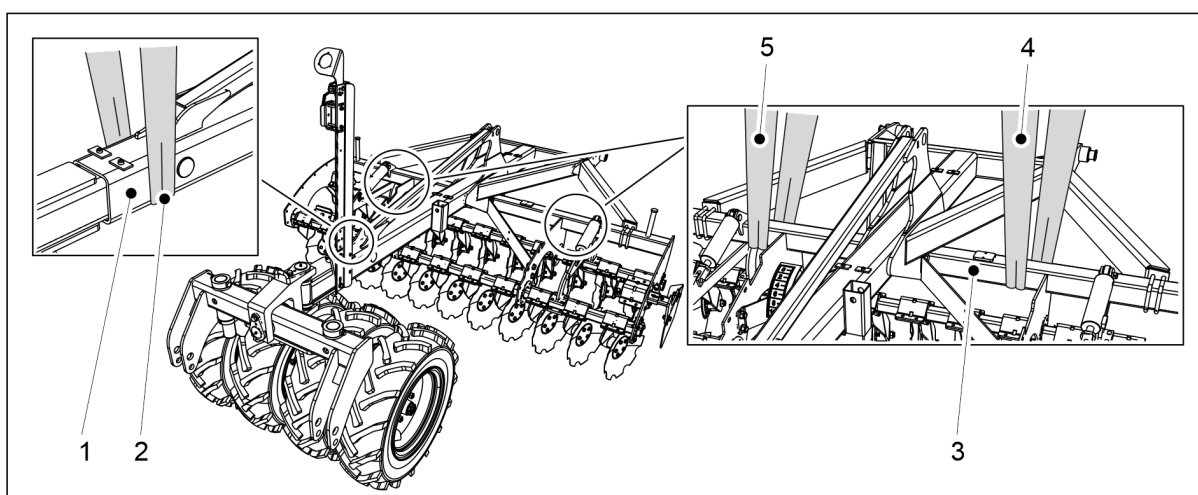

Figure. 5.1.6 - 52. Lifting the drawbar and front disc cultivator

6. Fasten a lifting sling (2) to the drawbar (1) close to the wheel packer and lifting slings (4, 5) to the cross-members of the drawbar (3).



DANGER

Ensure that the capacity of the lifting sling and the lifting device is sufficient.
FORTE 300 EVO: The total mass of the drawbar and front disc cultivator is 1100 kg.

FORTE 400 EVO: The total mass of the drawbar and front disc cultivator is 1300 kg.

7. Lift the drawbar and front disc cultivator.

8. Attach the drawbar to the seed drill as shown in section [5.1.1 Mounting the wheel packer](#).

9. Ensure that the front disc cultivator is lined up with the seed drill hopper.

- If necessary, loosen the mounting bolts and correct the front disc cultivator position.

5.1.7 Mounting the track eradicators



DANGER

The mounting of a track eradicator requires two people.



DANGER

Use a hoisting accessory when mounting a track eradicator.

Mounting track eradicators on a FORTE 300 EVO machine

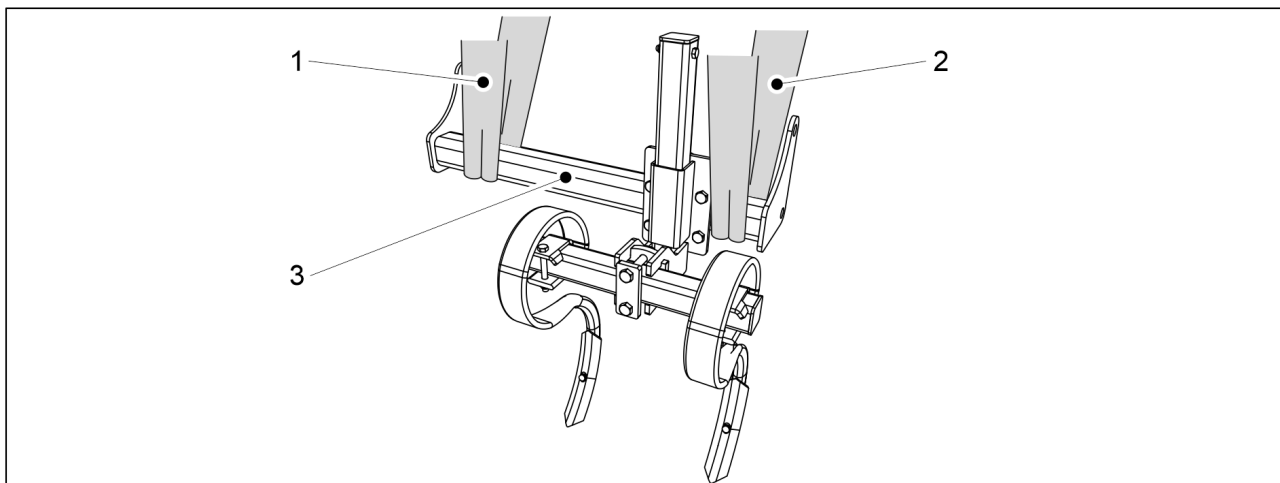

Figure. 5.1.7 - 53. Lifting a track eradicator

1. Fasten lifting slings (1, 2) around the tube (3).



DANGER

Ensure that the capacity of the lifting sling and the lifting device is sufficient. A track eradicator weighs 65 kg.

2. Use the lifting slings on the left side of the machine to lift the track eradicator up to the machine frame.

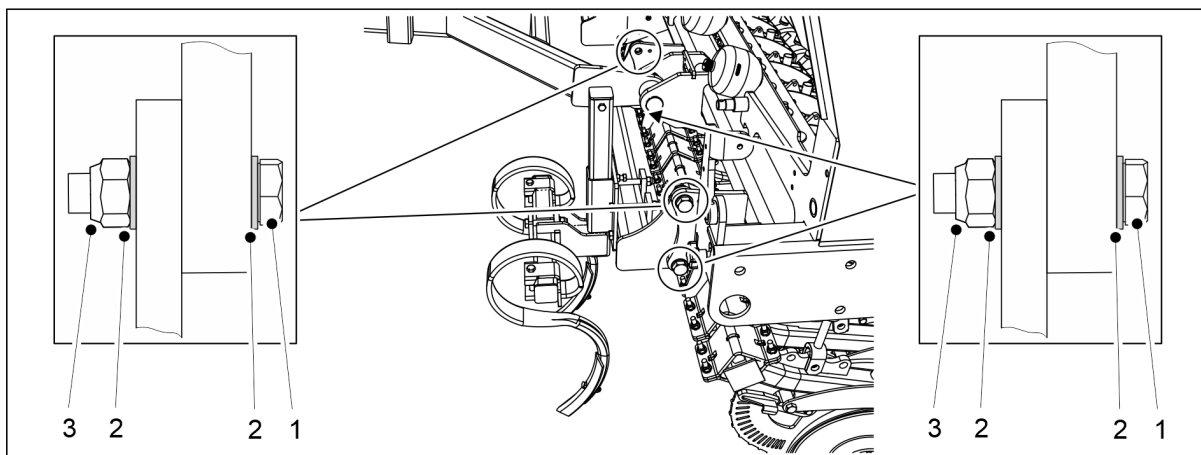

Figure. 5.1.7 - 54. Mounting a track eradicator

Number	Component	Pcs/track eradicator
1.	Hex screw M24x70	4
2.	Washer M24	8
3.	Locking nut M24	4

3. Attach the track eradicator to the machine frame using components (1-3).
4. Repeat steps 1 to 3 for the track eradicator on the right side of the machine.

Mounting track eradicators on a FORTE 400 EVO machine

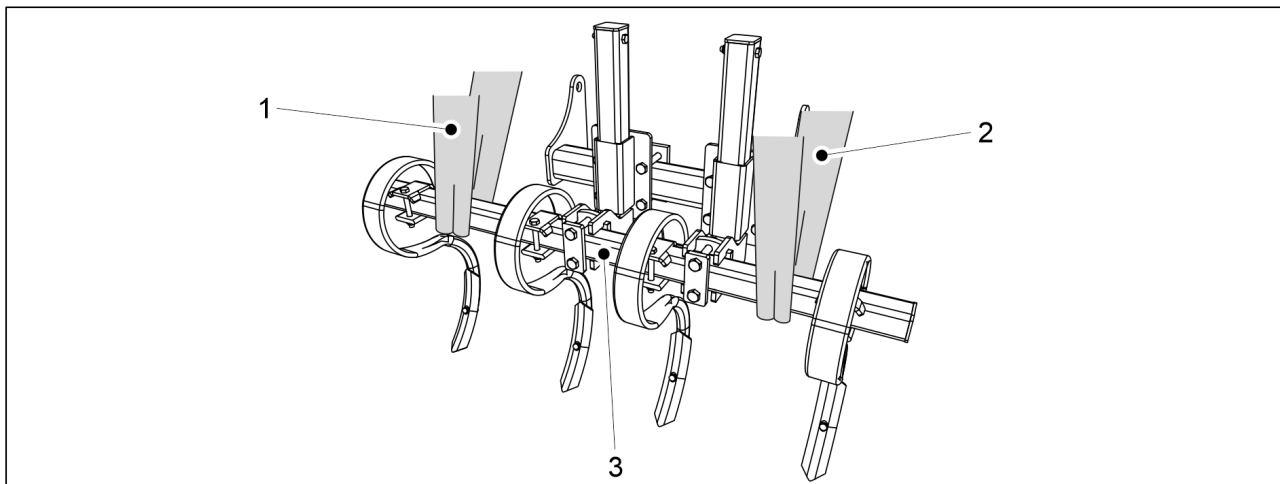

Figure. 5.1.7 - 55. Lifting a track eradicator

1. Fasten lifting slings (1, 2) around the tube (3).



DANGER

Ensure that the capacity of the lifting sling and the lifting device is sufficient. A track eradicator weighs 100 kg.

2. Use the lifting slings on the left side of the machine to lift the track eradicator up to the machine frame.

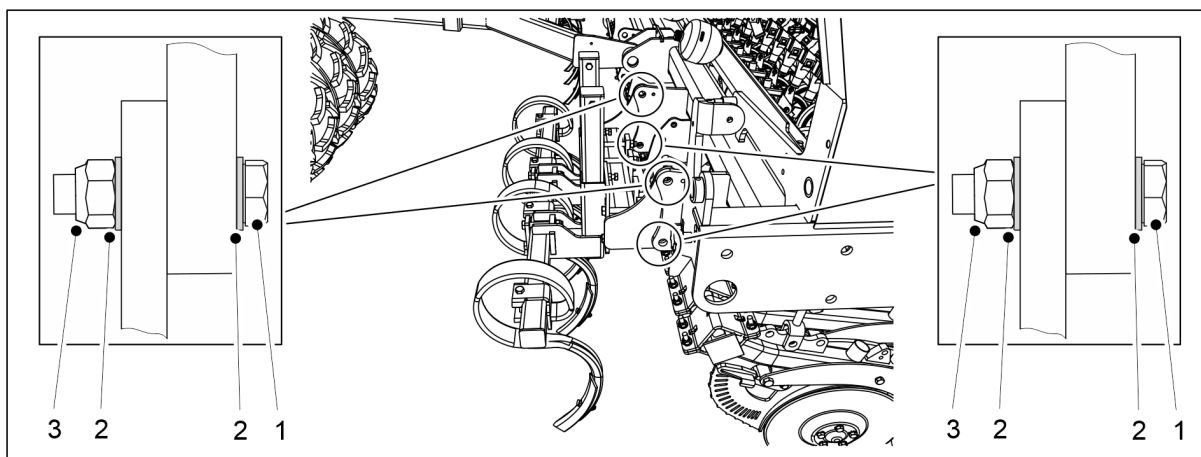

Figure. 5.1.7 - 56. Mounting a track eradicator

Number	Component	Pcs/track eradicator
1.	Hex screw M24x70	4
2.	Washer M24	8
3.	Locking nut M24	4

3. Attach the track eradicator to the machine frame using components (1-3).
4. Repeat steps 1 to 3 for the track eradicator on the right side of the machine.

5.1.8 Mounting the middle markers

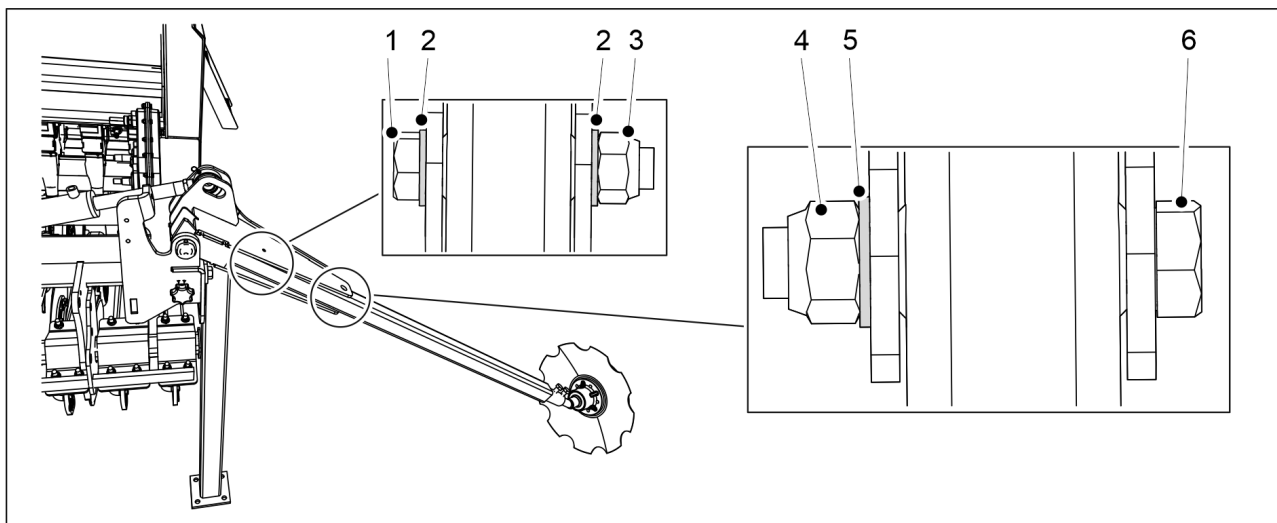

Figure. 5.1.8 - 57. Mounting the middle markers

Number	Component	Quantity
1.	Hex screw M8x100	2 pcs
2.	Washer M8	4 pcs
3.	Locking nut M8	2 pcs
4.	Locking nut M20	2 pcs
5.	Washer M20	2 pcs
6.	Hex screw M20x110	2 pcs

1. Mount the markers on the shaft of the markers on both sides of the seed drill by using components (1-6).
 - Tighten the bolts of the markers so that there is no clearance.

5.1.9 Removing the transport supports

- Once the front accessories have been mounted on the seed drill, it can be connected to the tractor in accordance with section [5.3 Connecting to tractor](#) and the transport supports can be removed.

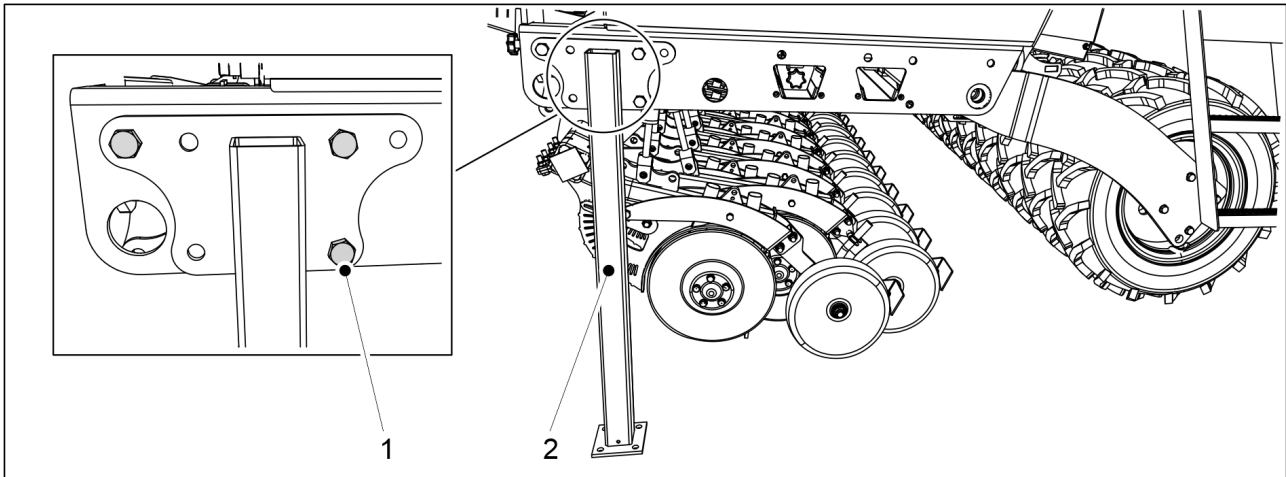

Figure. 5.1.9 - 58. Transport support

1. Open the three transport support bolts (1) and detach the transport supports (2) from both sides of the seed drill.

5.1.10 Fastening detached parts for packing

- The seed tube, fertiliser tube and cylinder may be detached from two of the seed drill's coulters during transport. Reattach the detached parts before operating the machine again.

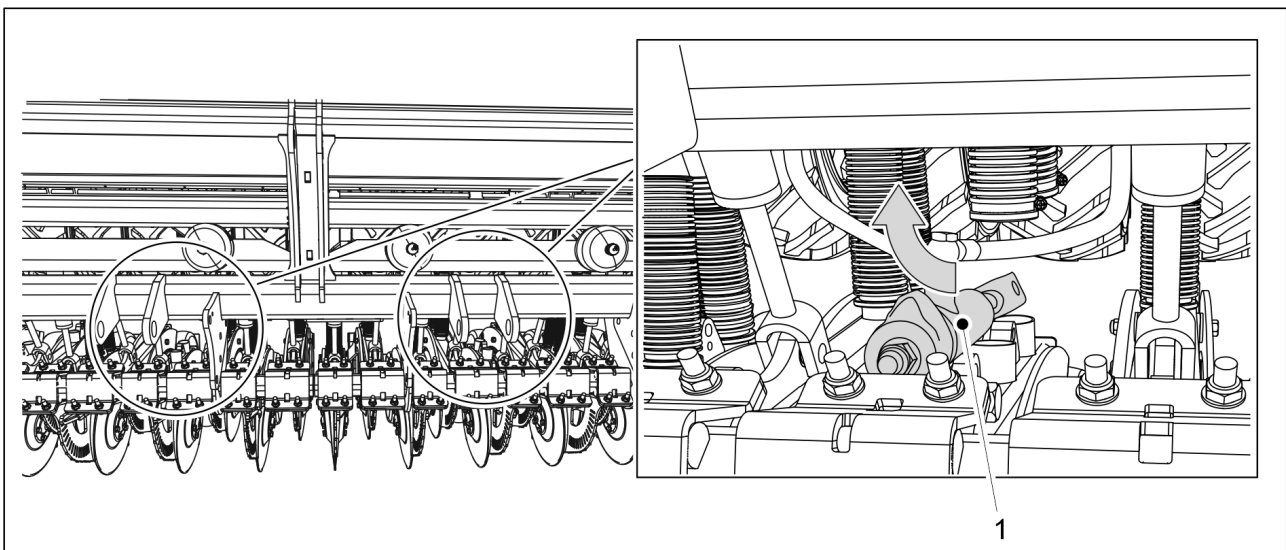

Figure. 5.1.10 - 59. Attaching the cylinder

1. Attach the coulters cylinder (1).
 - The fasteners are found on the cylinder.

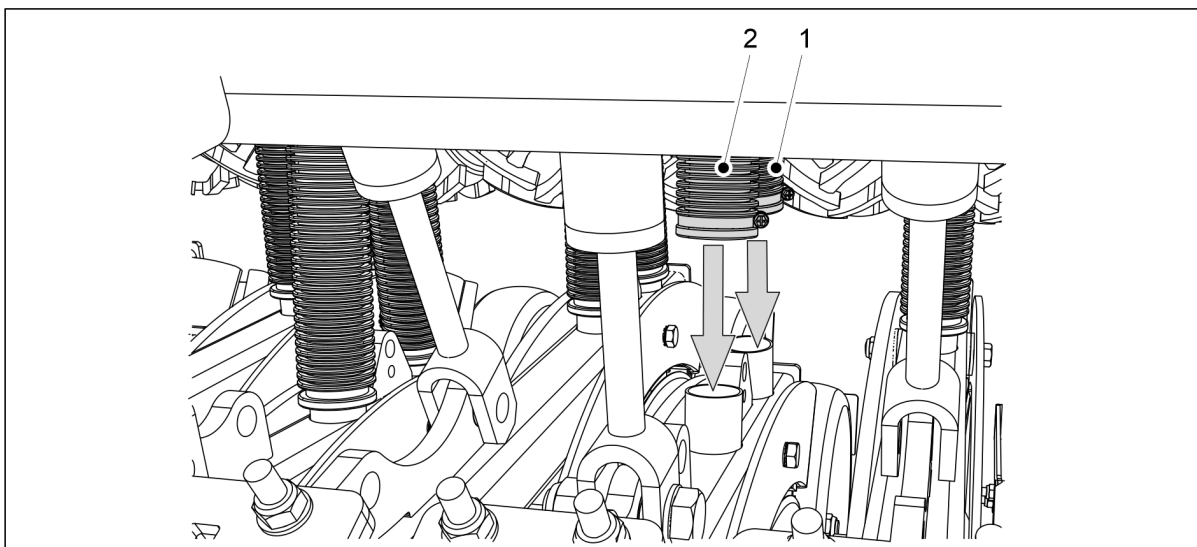

Figure. 5.1.10 - 60. Pulling down the seed and fertiliser tube

2. Pull the ends of the seed tube (1) and fertiliser tube (2) down to the coulter couplings.

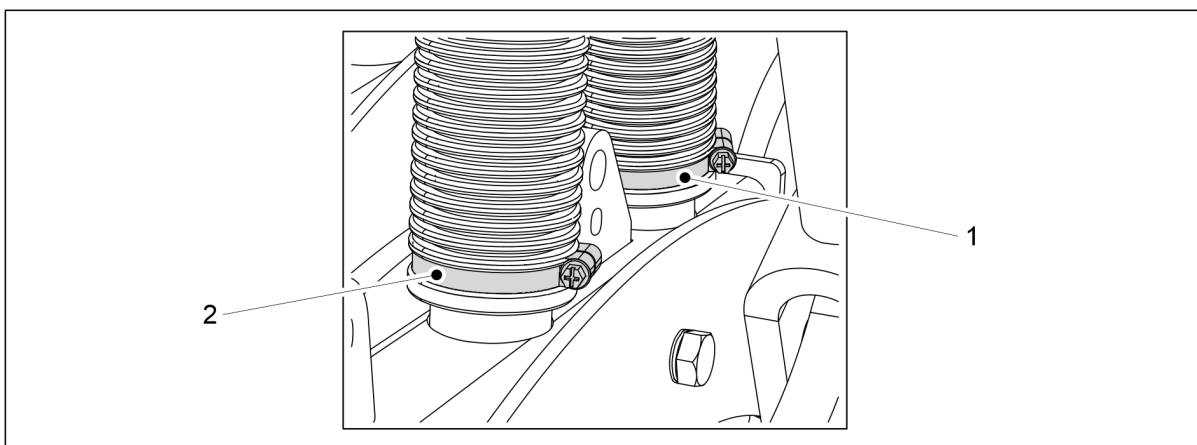

Figure. 5.1.10 - 61. Attaching the seed and fertiliser tube to the coulter

3. Attach the seed tube with the hose clamp (1).
4. Attach the fertiliser tube with the hose clamp (2).
 - The hose clamps are pre-installed on the tubes.

5.1.11 Mounting the scraper



DANGER
Mounting the scraper requires two people.

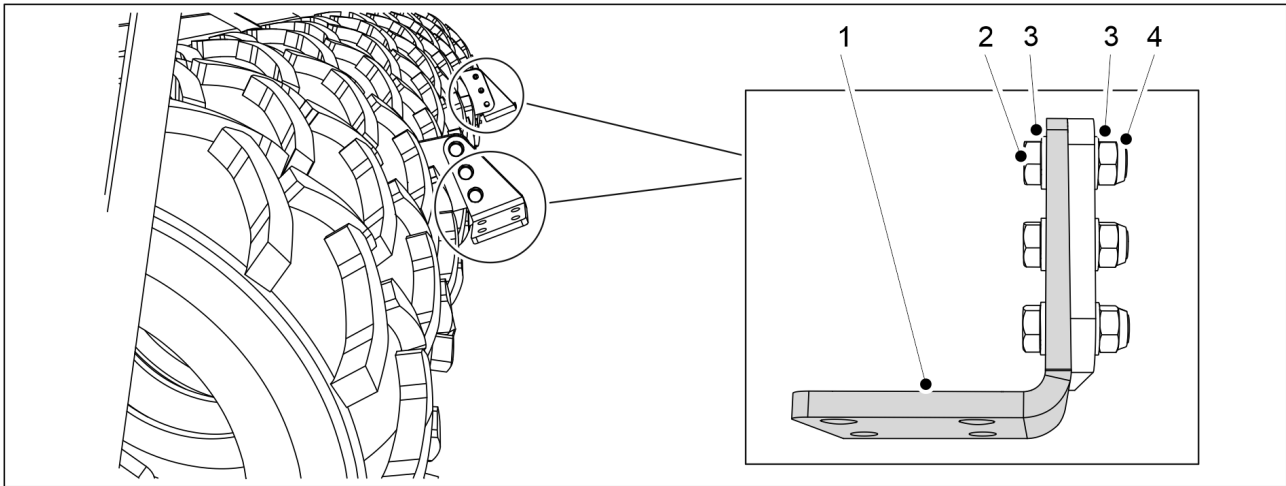

Figure. 5.1.11 - 62. Mounting the scraper suspension plates

Number	Component	Quantity
2.	Hex screw M16X50	6 pcs
3.	Washer M16	12 pcs
4.	Locking nut M16	6 pcs

1. Attach the two scraper suspension plates (1) to the machine with components (2-4).

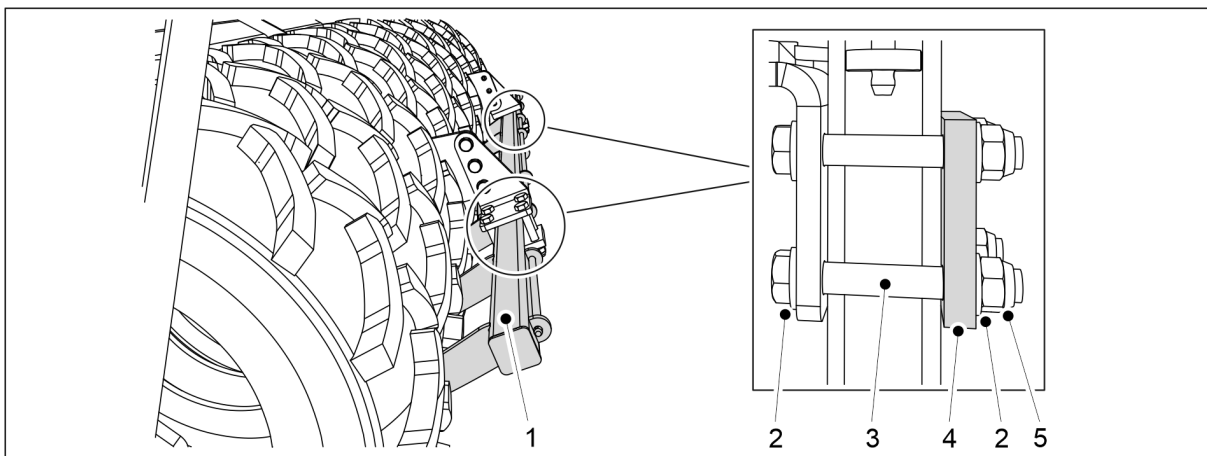

Figure. 5.1.11 - 63. Mounting the scraper

Number	Component	Quantity
2.	Washer M16	16 pcs
3.	Hex screw M16x110	8 pcs
4.	Plate	2 pcs
5.	Locking nut M16	8 pcs

2. Attach the scraper (1) to the suspension plates with components (2-5).

5.1.12 Attaching a scraper to a seed drill with brakes



DANGER
Mounting the scraper requires two people.

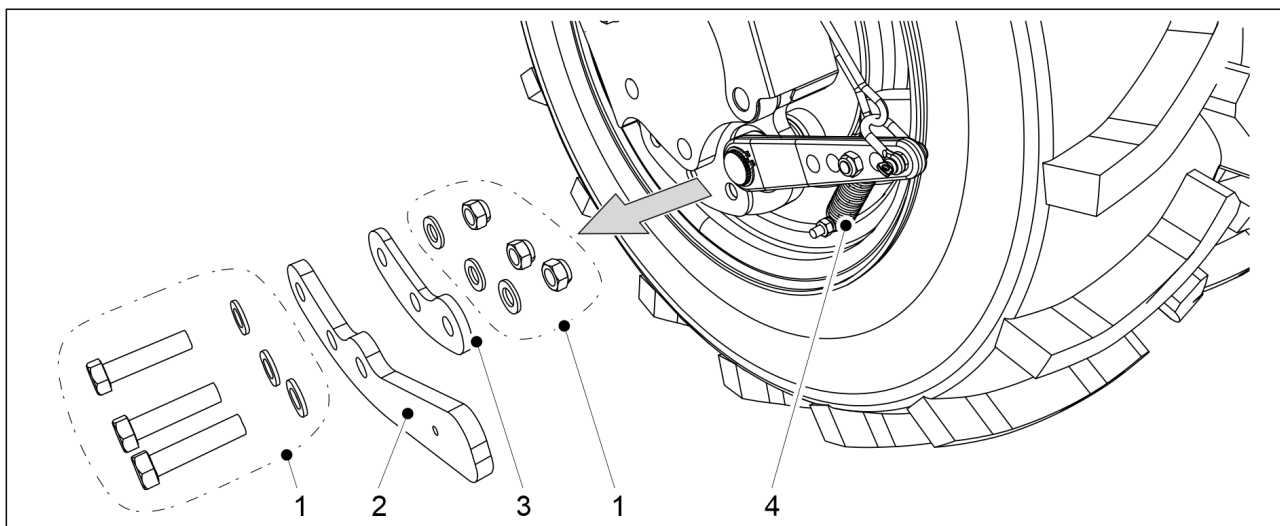

Figure. 5.1.12 - 64. Detaching the lever and shim

1. On the left side of the machine, remove the the lever (2) fasteners (1) from the outermost wheel with brakes at the rear.
2. Remove the lever (2) from the structure.
 - At the same time, remove the mounting at the bottom of the spring (4).
3. Repeat steps 1–2 on the right side of the machine.

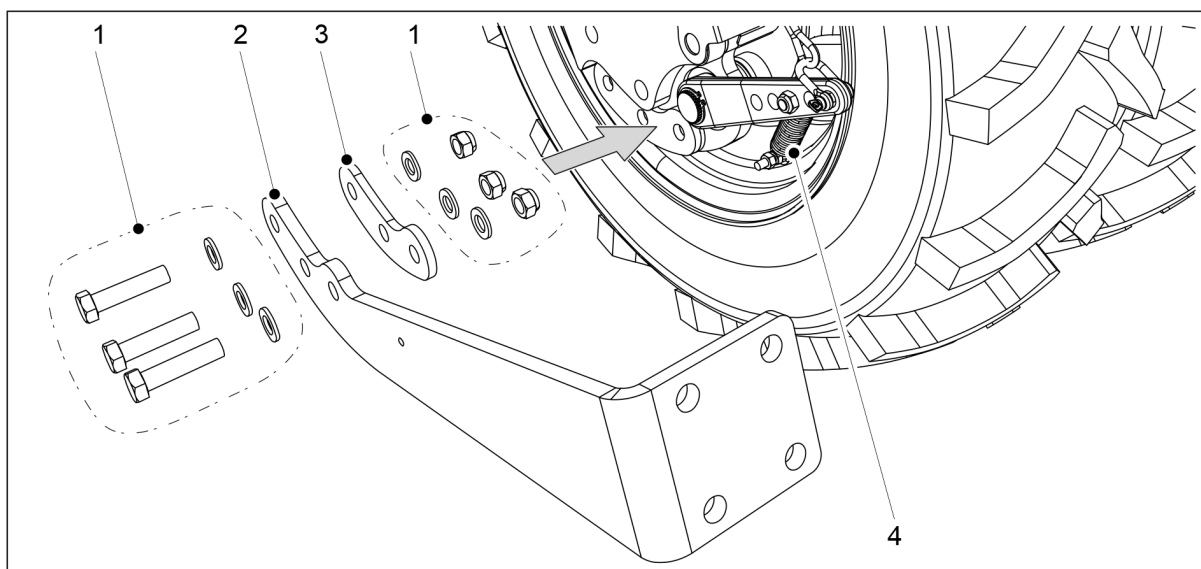

Figure. 5.1.12 - 65. Mounting the scraper to the attachment bracket

4. On the left side of the machine, attach the shim (3) and the scraper attachment bracket (2) to the outer wheel with the fasteners (1).
 - At the same time, fasten the bottom of the spring (4) to the attachment bracket.

5. Repeat steps 4 on the right side of the machine.

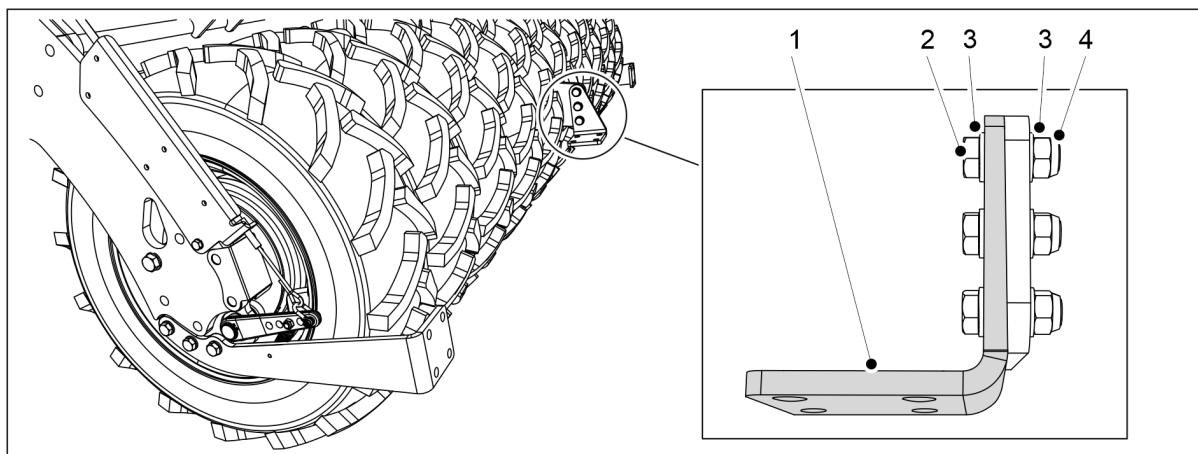

Figure 5.1.12 - 66. Mounting the scraper suspension plate

Number	Component	Quantity
2.	Hex screw M16X55	3 pcs
3.	Washer M16	6 pcs
4.	Locking nut M16	3 pcs

6. Attach the scraper suspension plates (1) to the machine with components (2-4).

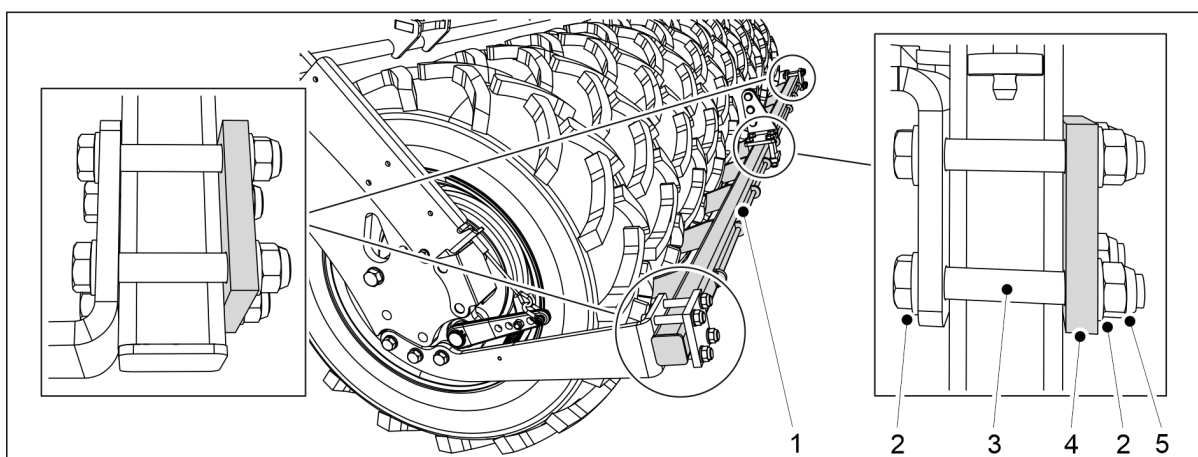

Figure 5.1.12 - 67. Mounting the scraper

Number	Component	Quantity
2.	Hex screw M16x110	12 pcs
3.	Washer M16	24 pcs
4.	Plate	3 pcs
5.	Locking nut M16	12 pcs

7. Attach the scraper (1) to the suspension plate and attachment brackets with components (2-5).

5.1.13 Mounting the rear harrow



DANGER

The mounting of the rear harrow requires two people.



DANGER

Use a hoisting accessory when mounting the rear harrow.

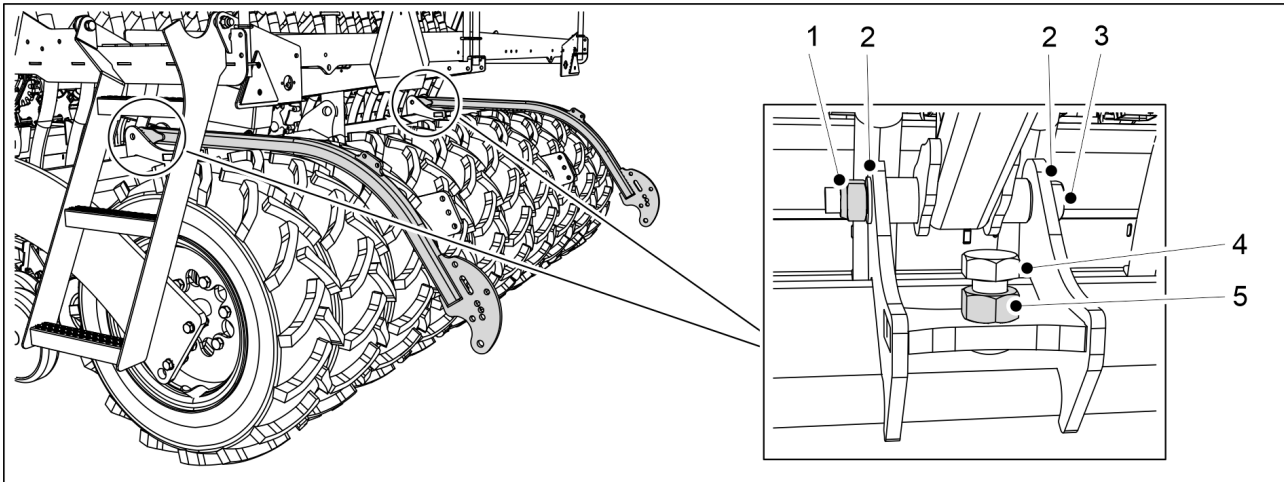

Figure. 5.1.13 - 68. Mounting the rear harrow arms

Number	Component	Quantity
1.	Locking nut M20	2 pcs
2.	Washer M20	4 pcs
3.	Hex screw M20x180	2 pcs
4.	Hex screw M24x55	2 pcs
5.	Hex nut M24	2 pcs

1. Attach the rear harrow arms to the seed drill with components (1-5).
 - Tighten the bolts of the rear harrow arms so that there is no clearance.

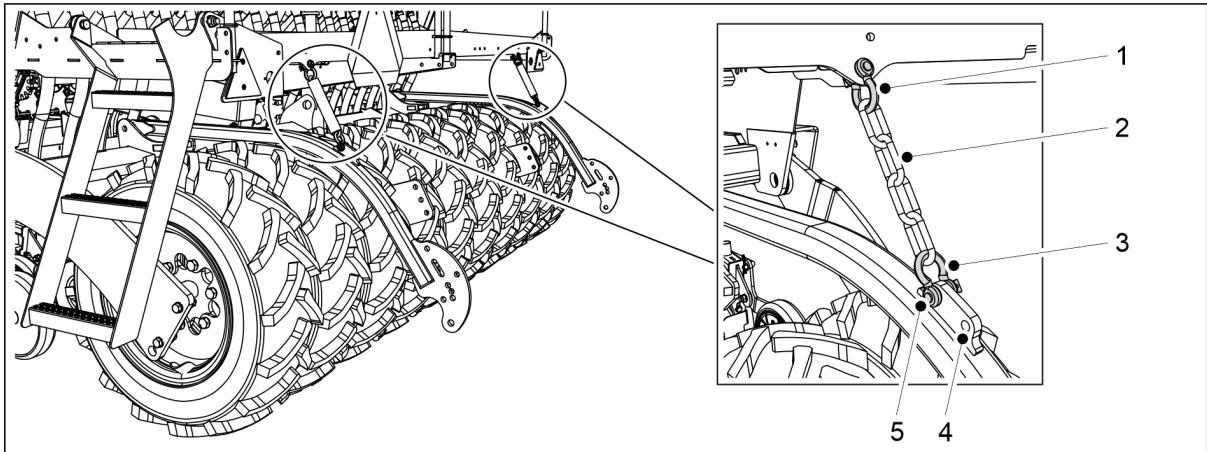

Figure. 5.1.13 - 69. Attaching the rear harrow chains

2. Attach the chains (2) to the working platform of the seed drill with shackles (1, 3).
 - There are two holes in the rear harrow arm for fastening the chain. The foremost hole is the default setting (5). If necessary, you can adjust the position of the rear harrow by using the rearmost hole (4).

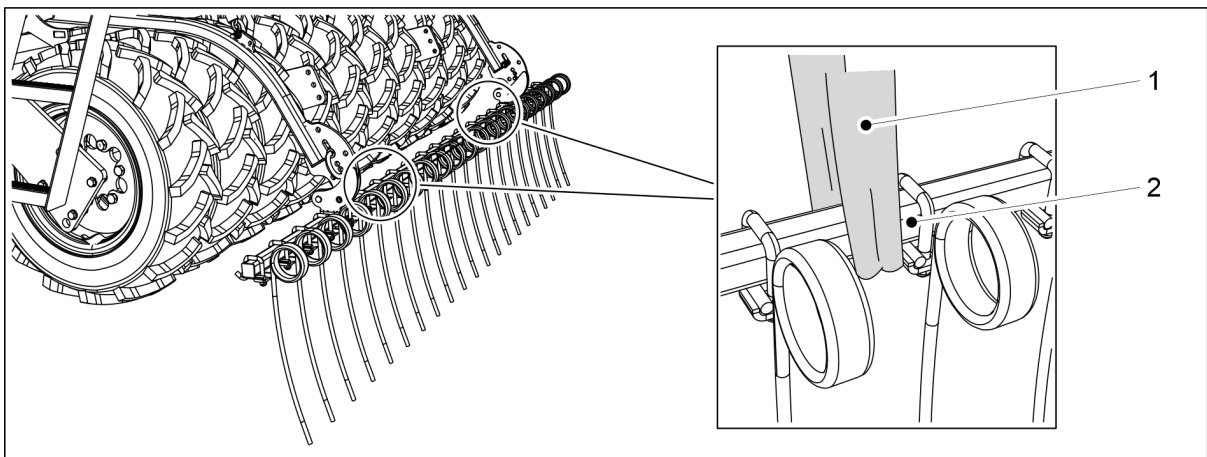

Figure. 5.1.13 - 70. Lifting the rear harrow

3. Tie a lifting sling (1) around the tube (2).



DANGER

Ensure that the capacity of the lifting sling and the lifting device is sufficient. The rear harrow weighs 100 kg.

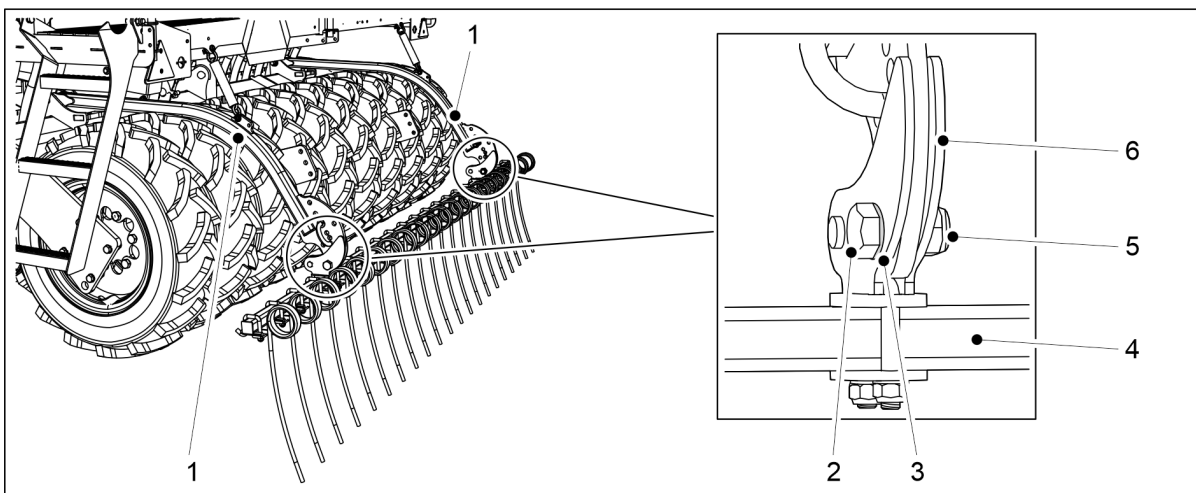

Figure. 5.1.13 - 71. Mounting the rear harrow

Number	Component	Quantity
1.	Rear harrow arm	2kpl
2.	Hex screw M20x60	2 pcs
3.	Washer M20	4 pcs
4.	Tube	1 pcs
5.	Locking nut M20	2 pcs
6.	Clamp	2 pcs

4. Use a lifting sling to raise the tube (4) of the rear harrow and position the tube so that the rear harrow arms (1) are between the clamps (6).
5. Attach the rear harrow tube to the rear harrow arms by fastening the clamp with washers (3), a hex screw (2) and a locking nut (5).
 - Tighten the bolts of the rear harrow so that there is no clearance.
6. Repeat step 5 for the other clamp.

5.1.14 Mounting the rear markers on the rear harrow



DANGER
 Mounting rear markers requires two people.



DANGER
 Use hoisting equipment when mounting the rear markers.

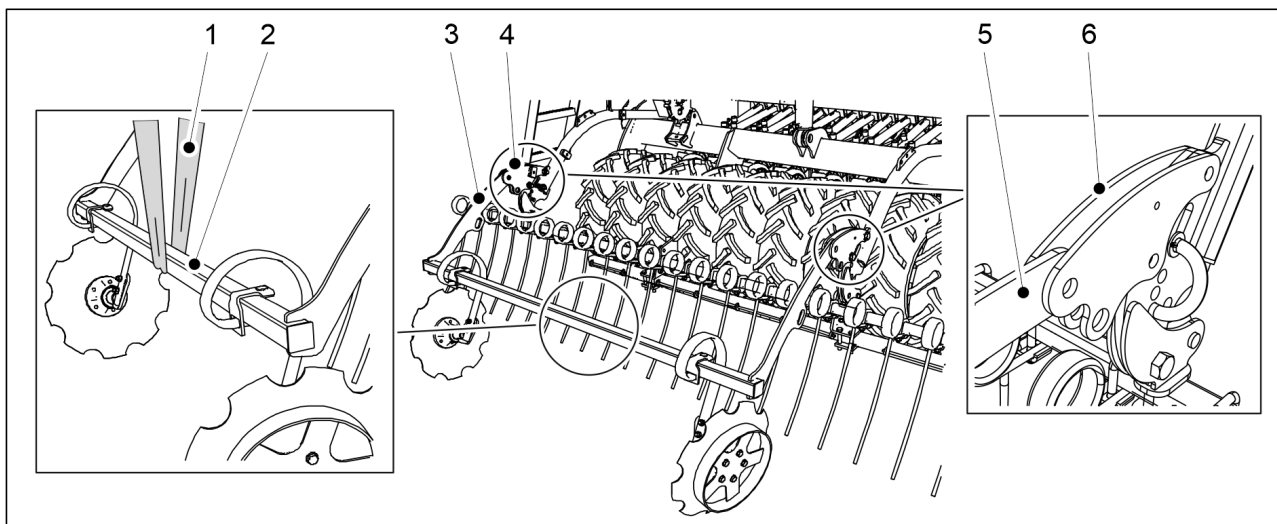

Figure. 5.1.14 - 72. Lifting the rear markers

1. Attach a lifting sling (1) around the marker frame (2).



DANGER

Ensure that the capacity of the lifting sling and the lifting device is sufficient. The rear markers weigh 75 kg.

2. Lift the rear markers with a lifting sling (1) through the frame (2) and place the frame so that the rear marker arms (3, 5) are between the front levelling board actuating arms (4, 6).

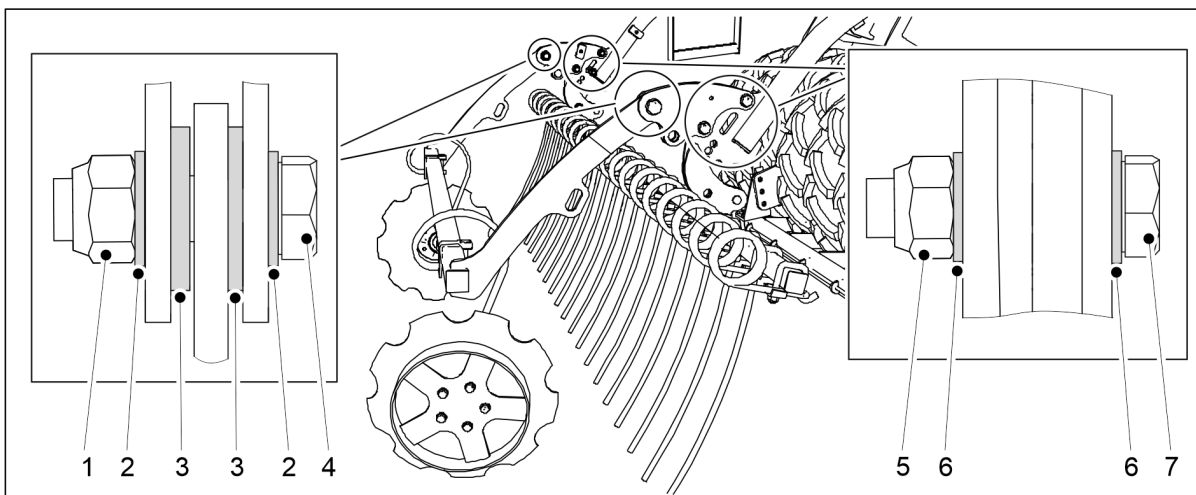

Figure. 5.1.14 - 73. Mounting the rear markers on the rear harrow

Number	Component	Quantity
1.	Locking nut M20	2 pcs
2.	Washer M20	4 pcs
3.	Washer M20	4 pcs
4.	Hex screw M20x70	2 pcs
5.	Locking nut M16	4 pcs

6.	Washer M16	8 pcs
7.	Hex screw M16x70	4 pcs

3. Attach the rear markers to front levelling board actuating arms with washers (2, 3, 6), hex screws (4, 7) and locking nuts (1, 5).
4. Repeat step 3 for the second attachment point.

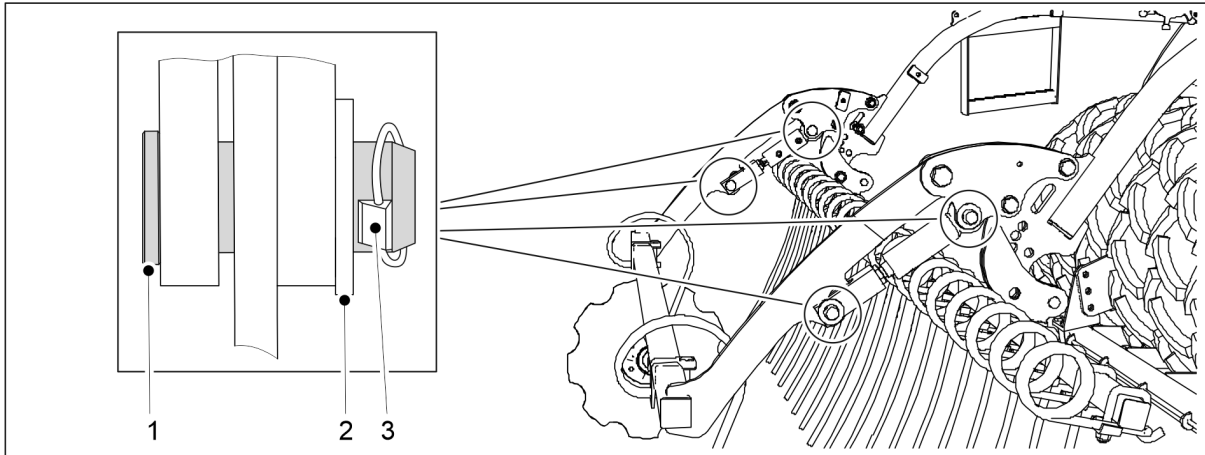

Figure. 5.1.14 - 74. Mounting rear marker cylinders

Number	Component	Quantity
1.	Pin Ø24	4 pcs
2.	Washer M24	4 pcs
3.	Linchpin	4 pcs

5. Take the cylinder from the working platform and mount it on the actuating arm with pins (1) and washers (2).
6. Lock the mounting pin in place with the linchpin (3).
7. Repeat steps 5-6 for the second cylinder.

5.1.15 Mounting the front working platform to a machine with a standard drawbar

- Attach the front working platform before installing the drawbar cylinder/turnbuckle.



DANGER

The mounting of the front working platform requires two people.



DANGER

Use a hoisting accessory to install the front working platform walkway.

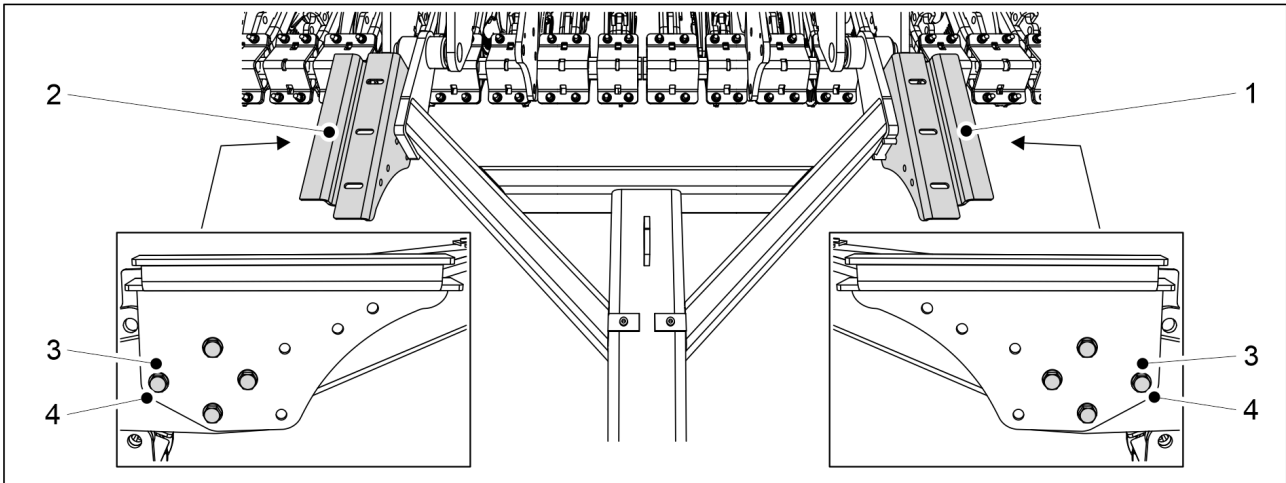

Figure. 5.1.15 - 75. Mounting the walkway support brackets

1. Mount the walkway support brackets (1, 2) to the drawbar with 8 bolts M12x75 (3) and 8 washers M12 (4).

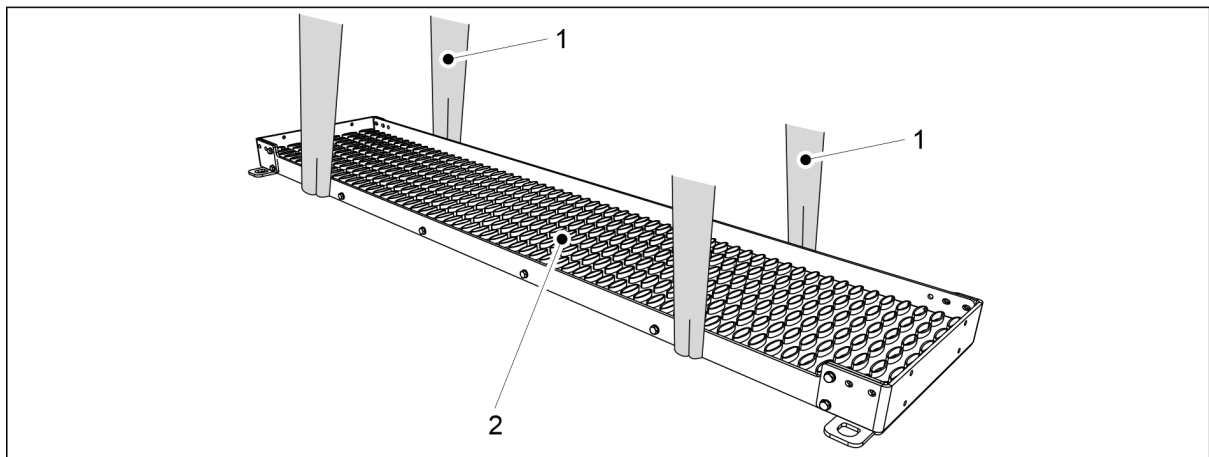

Figure. 5.1.15 - 76. Lifting the walkway

2. Fasten 2 lifting slings (1) around the walkway (2).



DANGER

Ensure that the capacity of the lifting sling and the lifting device is sufficient.
FORTE 300 EVO: The walkway weighs 60 kg. FORTE 400 EVO: The walkway weighs 80 kg.

3. Use the lifting slings to lift the walkway above the drawbar.
4. Align the walkway symmetrically with the centre of the machine and lower it onto the support brackets.

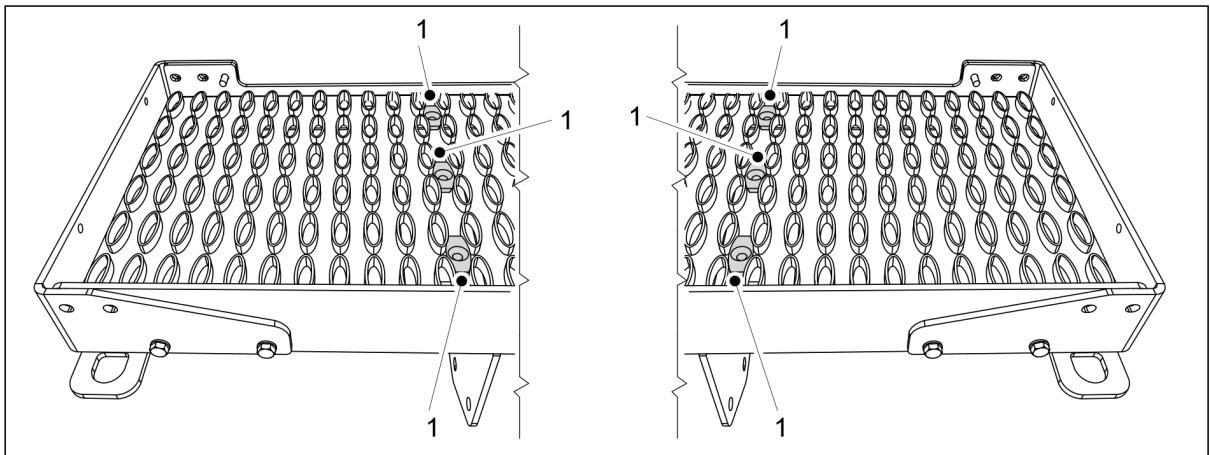

Figure. 5.1.15 - 77. Walkway brackets

5. Fit 6 brackets (1). in the screw holes of the walkway brackets.

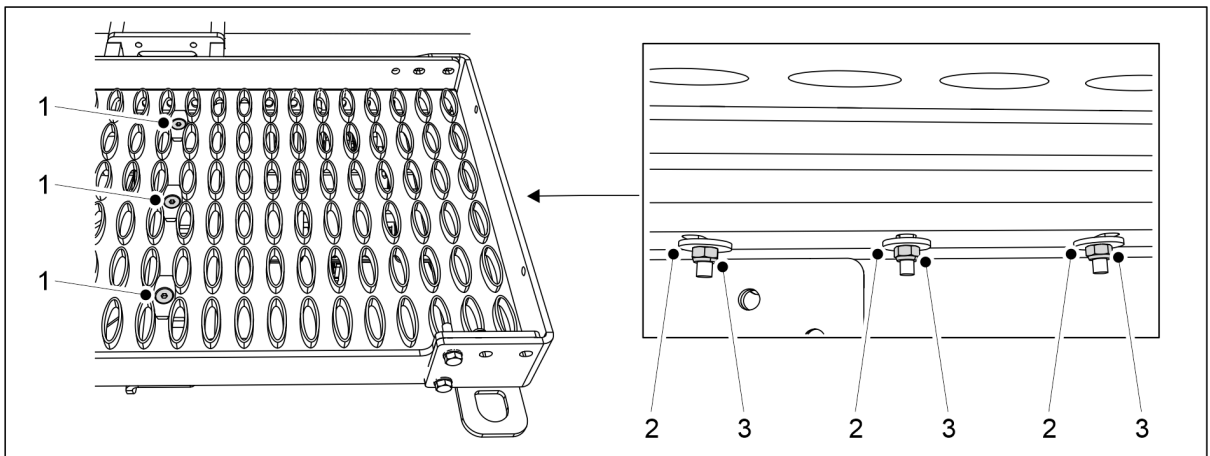

Figure. 5.1.15 - 78. Mounting the walkway onto the brackets

Number	Component	Pcs
1.	Hex screw, countersunk M8x70	6
2.	Washer M8	6
3.	Locking nut M8	6

6. Attach the walkway to the brackets with components (1-3).

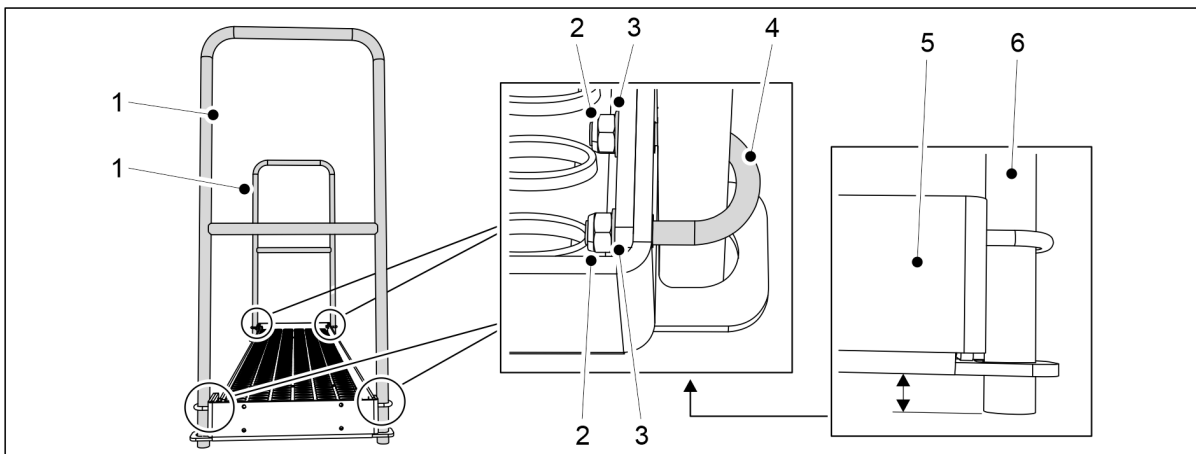

Figure. 5.1.15 - 79. Mounting handrails on a FORTE 300 EVO machine

Number	Component	Pcs
2.	U-bolt	4
3.	Washer M8	8
4.	Locking nut M8	8

7. FORTE 300 EVO: Attach 2 handrails (1) to the ends of the walkway with components (2-4).

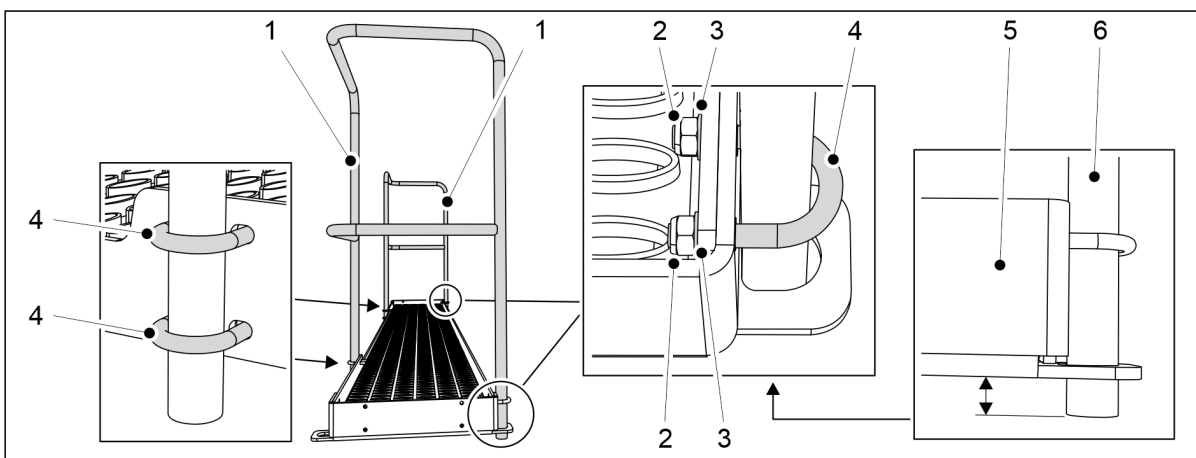

Figure. 5.1.15 - 80. Mounting handrails on a FORTE 400 EVO machine

Number	Component	Pcs
2.	Locking nut M8	12
3.	Washer M8	12
4.	U-bolt	6

8. FORTE 400 EVO: Attach 2 handrails (1) to the ends and front of the walkway with components (2-4).

- Position the ends of the handrail tubes (5) slightly below the end plates (6) of the walkway.

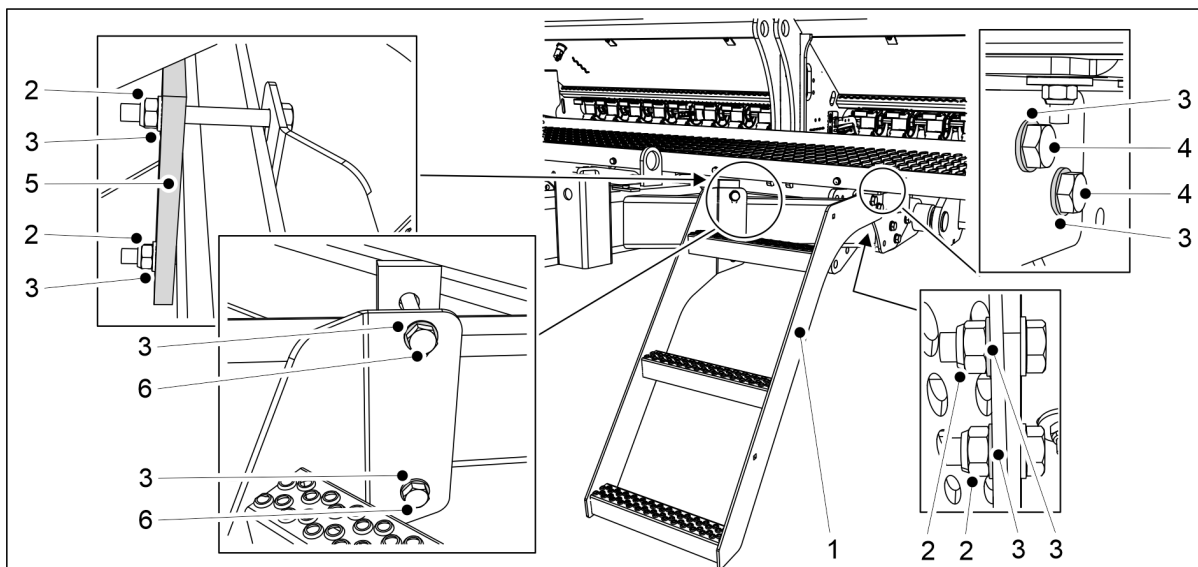

Figure. 5.1.15 - 81. Installing the stairs

Number	Component	Pcs
2.	Locking nut M12	4
3.	Washer M12	8
4.	Hex screw M12x35	2
5.	Mounting plate	1
6.	Hex screw M12x110	2

9. Attach the stairs (1) to the drawbar with components (2-6).

5.1.16 Mounting the front working platform to a machine with a front disc cultivator

- Attach the front working platform before installing the drawbar cylinder/turnbuckle.



DANGER

The mounting of the front working platform requires two people.



DANGER

Use a lifting aid to install the front working platform walkway.

1. Mount the front disc calculator onto the machine as stated in chapter [5.1.6 Mounting the front disc cultivator](#).

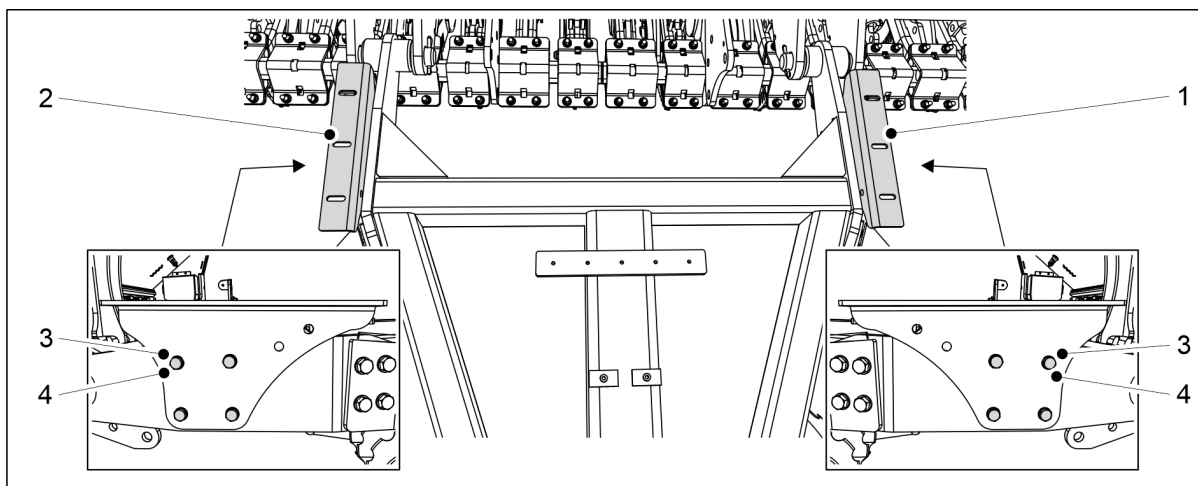

Figure. 5.1.16 - 82. Mounting the walkway support brackets

2. Mount the walkway support brackets (1, 2) to the drawbar with bolts M10x30 (3) 8 pcs and washers M10 (4) 8 pcs.

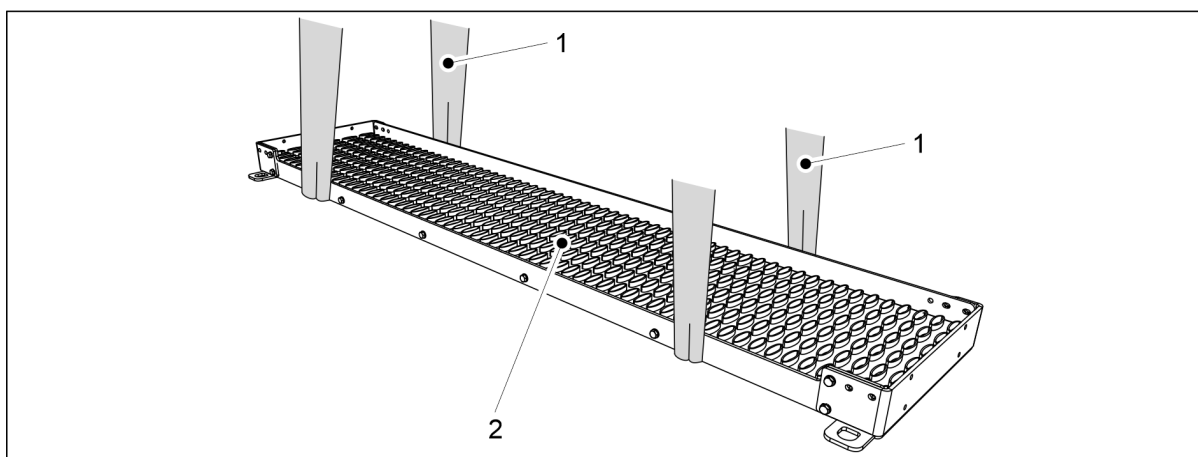

Figure. 5.1.16 - 83. Lifting the walkway

3. Fasten 2 lifting slings (1) around the walkway (2).



DANGER

Ensure that the capacity of the lifting sling and the lifting device is sufficient.
FORTE 300 EVO: The walkway weighs 60 kg. FORTE 400 EVO: The walkway weighs 80 kg.

4. Use the lifting slings to lift the walkway above the drawbar.
5. Align the walkway symmetrically with the centre of the machine and lower it onto the support brackets.

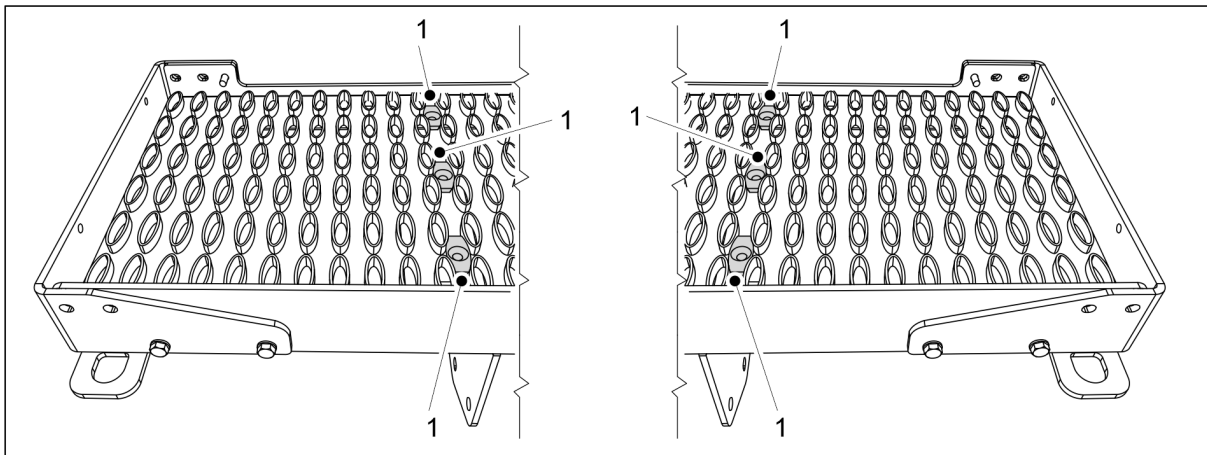

Figure. 5.1.16 - 84. Walkway brackets

6. Fit 6 brackets (1). in the screw holes of the walkway brackets.

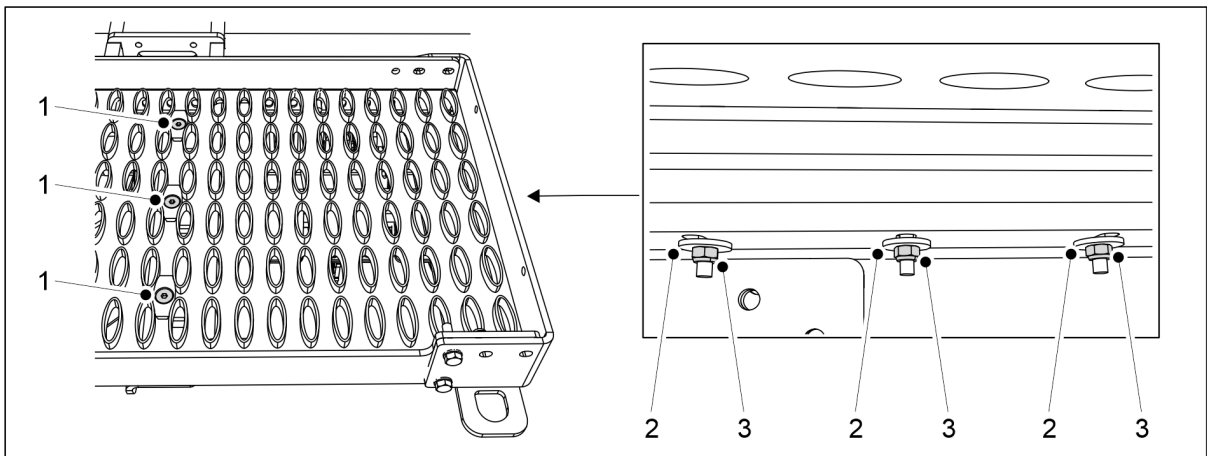

Figure. 5.1.16 - 85. Mounting the walkway onto the brackets

Number	Component	Pcs
1.	Hexagon socket head screw, countersunk M8x70	6
2.	Washer M8	6
3.	Locking nut M8	6

7. Attach the walkway to the brackets with components (1-3).

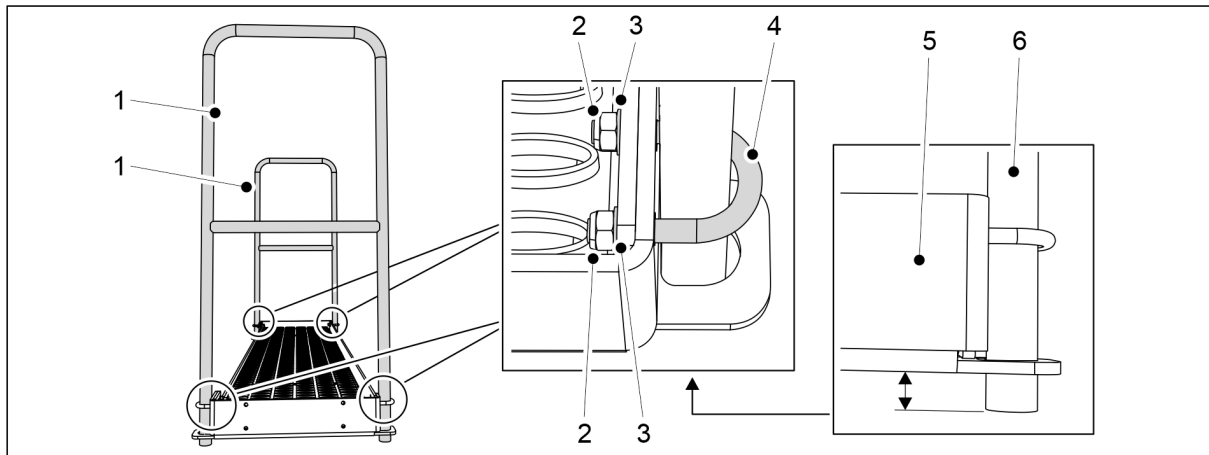

Figure. 5.1.16 - 86. Mounting handrails on a 300 machine

Number	Component	Pcs
2.	U-bolt	4
3.	Washer M8	8
4.	Locking nut M8	8

8. 300 machine: Attach 2 rails (1) to the ends of the walkway with components (2-4).

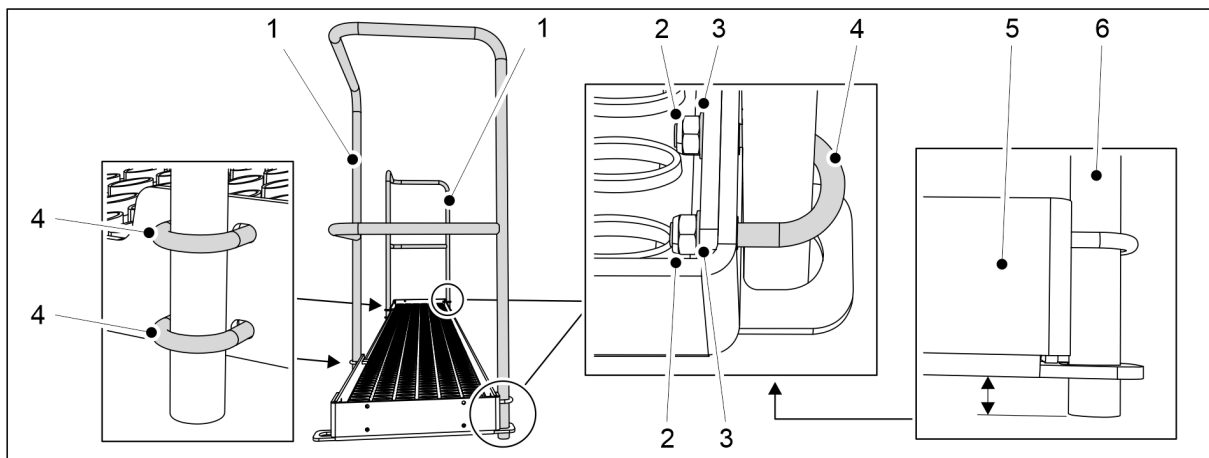

Figure. 5.1.16 - 87. Mounting handrails on a 400 machine

Number	Component	Pcs
2.	Locking nut M8	12
3.	Washer M8	12
4.	U-bolt	6

9. 400 machine: Attach 2 handrails (1) to the ends and front of the walkway with components (2-4).

- Position the ends of the handrail tubes (5) slightly below the end plates (6) of the walkway.

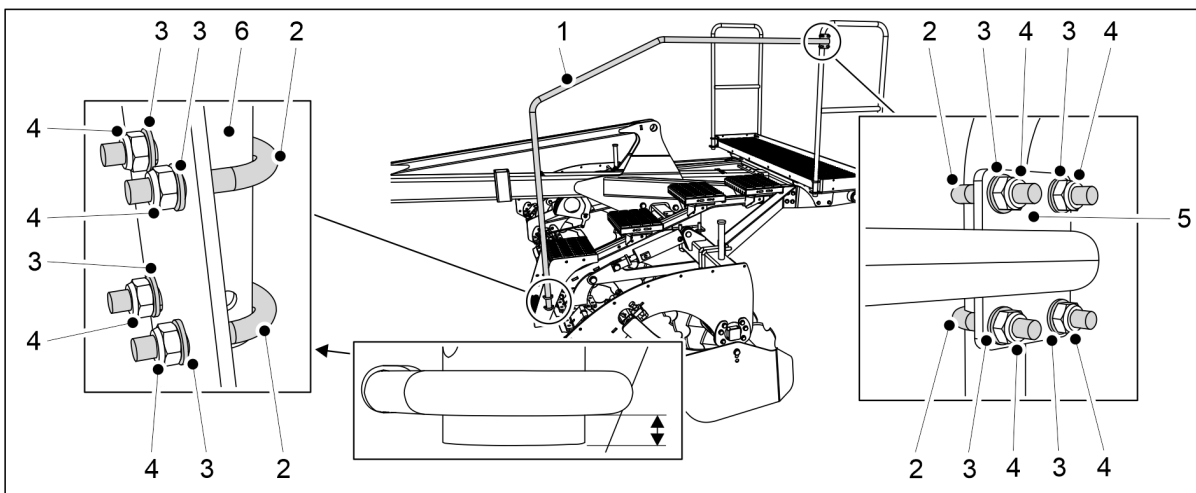

Figure. 5.1.16 - 88. Mounting the stair rail

Number	Component	Pcs
2.	U-bolt	4
3.	Washer M8	8
4.	Locking nut M8	8

10. Attach the bottom (6) of the stair rail (1) to the front disc cultivator stairs with components (2-4).

- Position the bottom of the stair rail just below the U-bolt.

11. Use components (2-4) to attach the top bracket (5) of the stair rail (1) to the front working platform.

5.1.17 Turning the rear railing of the working platform and attaching the end railing

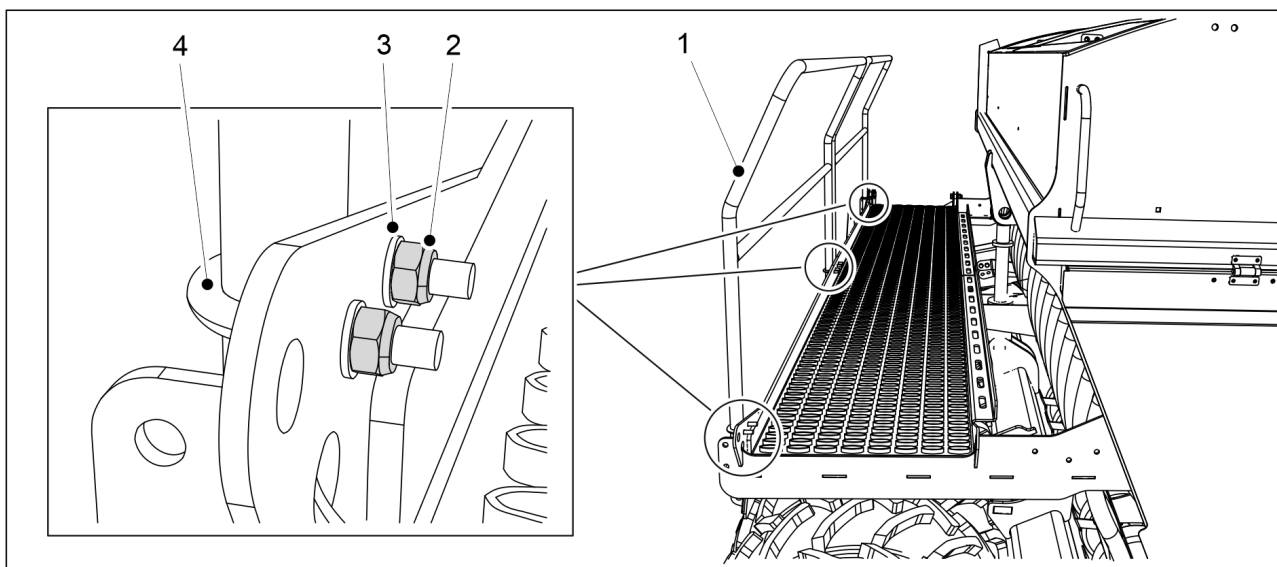

Figure. 5.1.17 - 89. Turning the rear railing of the working platform

Number	Component	Quantity
1.	Rear railing	1 pcs
2.	Locking nut M8	8 pcs
3.	Washer M8	8 pcs
4.	U-bolt	4 pcs

- For transport, the rear railing (1) of the working platform has been turned inward.
1. Open the bolts of the rear railing of the working platform.
 2. Turn the railing outward and attach it to the working platform with washers (3), U-bolt (4) and locking nuts (2).
 3. Repeat step 2 for all attachment points of the rear railing.

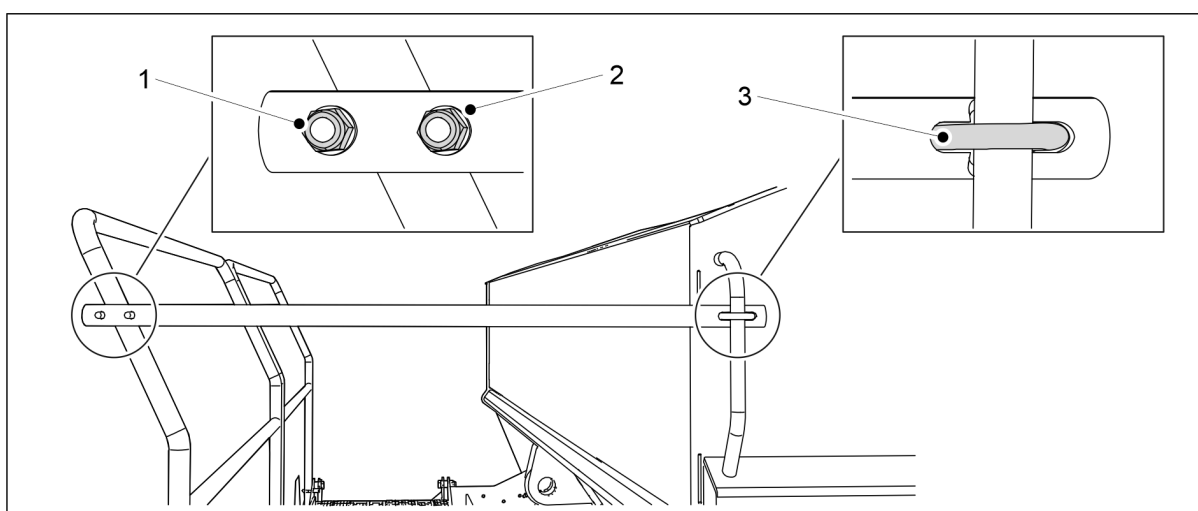

Figure. 5.1.17 - 90. Attaching the end railing of the working platform

Number	Component	Quantity
1.	Locking nut M8	4 pcs
2.	Washer M8	4 pcs
3.	U-bolt	2 pcs

4. Attach the end railing to the working platform with washers (2), U-bolt (3) and locking nuts (1).
5. Repeat step 4 for the second attachment point.

5.2 Commissioning

5.2.1 Installing the Comfort control panel

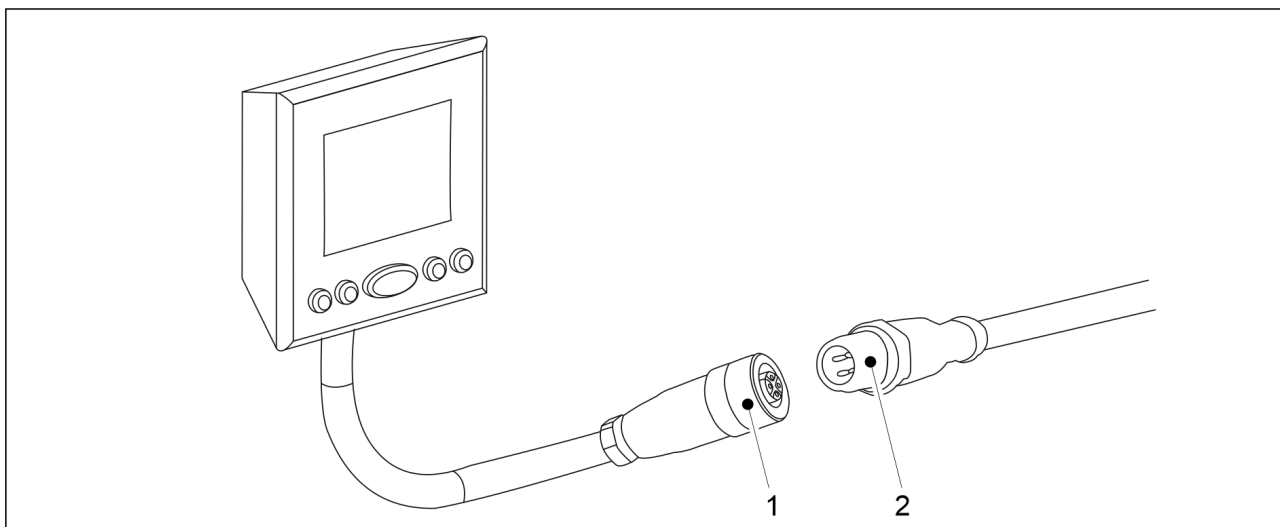

Figure. 5.2.1 - 91. Installing the Comfort control panel

1. Connect the cable (1) of the Comfort control panel to the cable (2) connected to the seed drill.
 - Fasten the cable properly so that it is not pinched during turns or lifting.

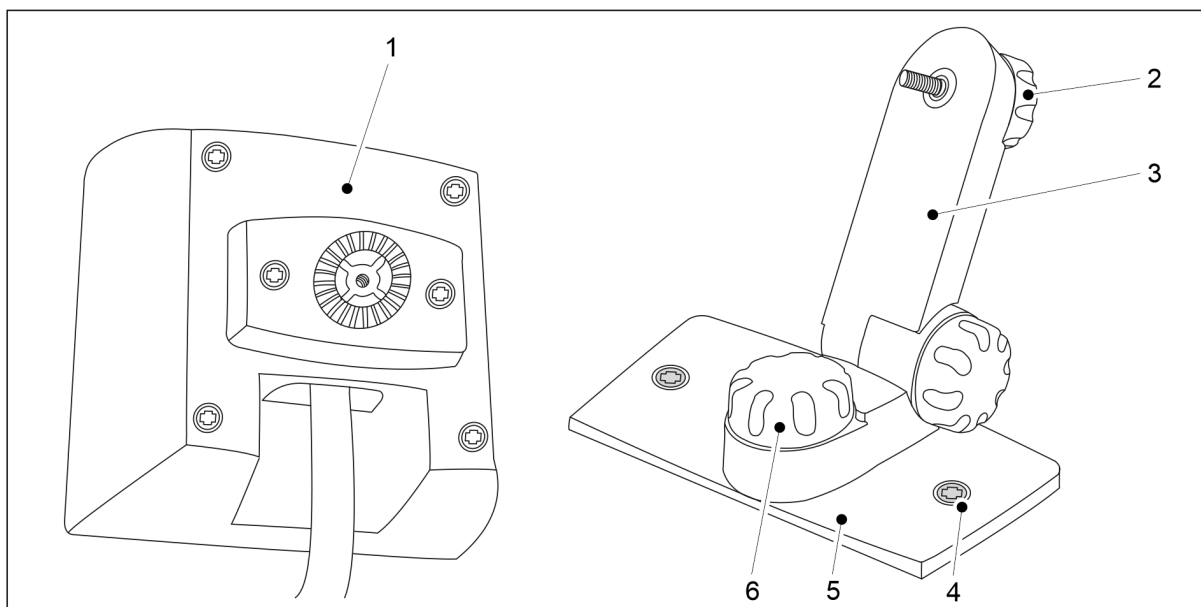

Figure. 5.2.1 - 92. Fastening the Comfort control panel

2. Fasten the display bracket (3) to the plate (5) by using a screw (6).
3. Fasten the display bracket (4) to the cabin with two fastening screws (4).
 - Attach the display in a location where view is not obstructed but where the display is easily viewable by turning one's glance while driving. Fasten the display at a suitable height so that the buttons can be reached effortlessly.
4. Fasten the controller display (1) to the display bracket (3) by using a screw (2).

5.3 Connecting to tractor



DANGER

Crushing hazard when connecting and disconnecting the seed drill. The minimum safe distance - 5 m. Exercise extreme caution when there are personnel near the seed drill and tractor giving instructions on connecting and disconnecting.

- Wear protective gloves when connecting the seed drill to the tractor.
1. Ensure that the tractor valve used for the hydraulics to lift the seed drill into its transport position is not in the float position.
 2. If the machine is equipped with a wheel packer, adjust the length of the wheel packer drawbar in accordance with section 5.3.1 Adjusting the wheel packer boom length.
 3. Connect the drawbar of the seed drill to the tractor hitch or the wheel packer draw boom to the tractor's link arms.
 4. Raise the machine with the tractor hydraulics.
 5. Raise the ground support to the top position according to the instructions given in section 5.3.2 Using the ground support.

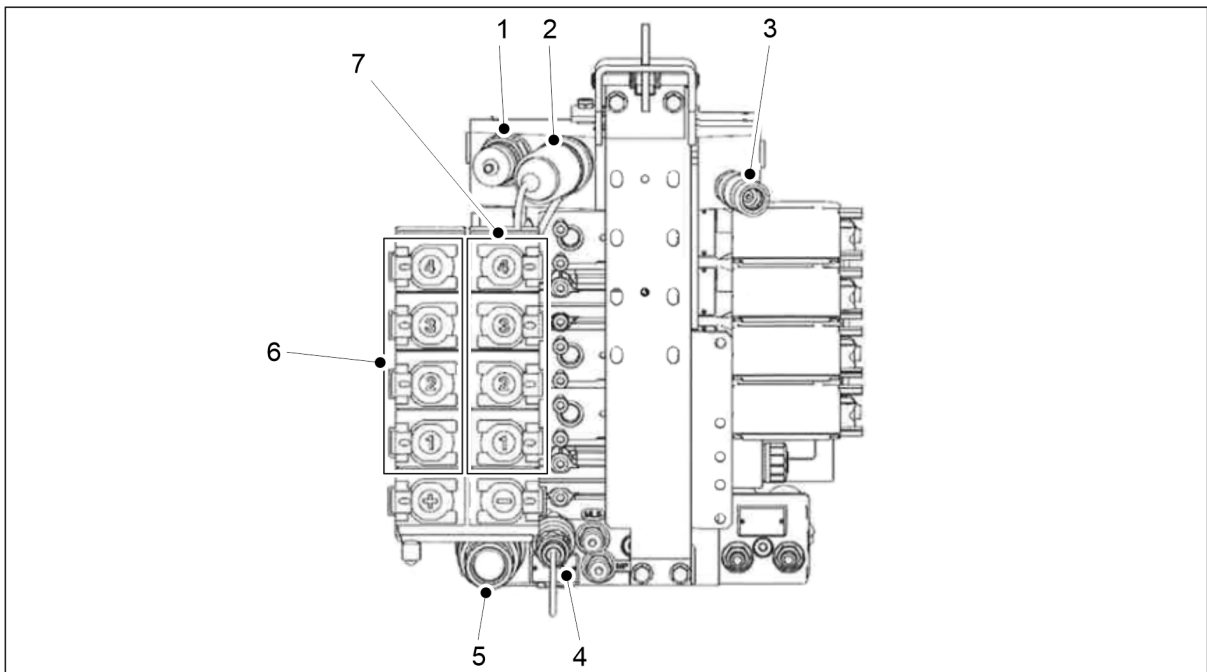

Figure. 5.3 - 93. Valtra T series hydraulic couplings are provided as a coupling model

1.	Power Beyond return (back pressure 8 bar)
2.	Power Beyond pressure
3.	LS control
4.	Overflow connection (do not connect a return line)
5.	Free return connection
6.	Double-acting connections 1- 4. + function connections
7.	Double-acting connections 1- 4. - function connectors

6. Connect the hydraulic hoses of the seed drill to the tractor's double-acting spool valve (6, 7).



DANGER
 Ensure that the tractor is turned off and the key is removed from the ignition.



DANGER
 Hydraulic hoses must be depressurised when connecting them.

- Connect hydraulic hoses in pairs so that the directions of flow are correct. The hydraulic hoses are marked with colour-coded collars. Check the tractor manual to ensure the hydraulic connections are suitable.

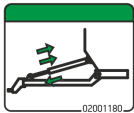
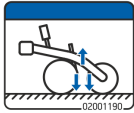
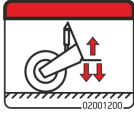
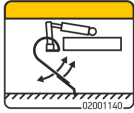
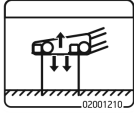
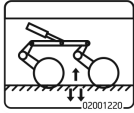
Number	Hydraulic hose	Colour code and symbol
1.	Hydraulic connection of the drawbar adjustment ◦ 2 male connectors of 1/2"	
2.	Hydraulic connection of the coulter pressure adjustment ◦ 2 male connectors of 1/2"	
3.	Hydraulic connection for raising the machine to the transport position ◦ 2 male connectors of 1/2"	
4.	Hydraulic connection of the adjustment of the front levelling board position ◦ 2 male connectors of 1/2"	
5.	Hydraulic connection of the front harrow position adjustment ◦ 2 male connectors of 1/2"	
6.	Hydraulic connection of the adjustment of the front disc cultivator position ◦ 2 male connectors of 1/2"	

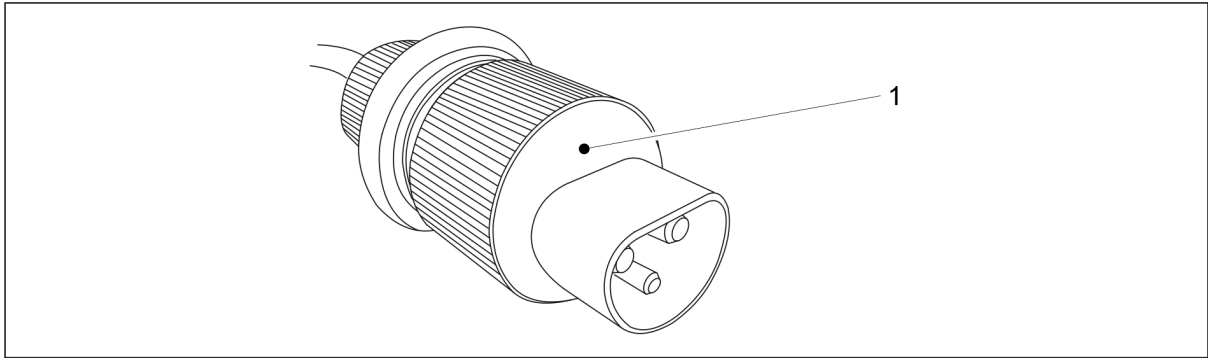

Figure. 5.3 - 94. Comfort controller power cable DIN 9680

7. Connect the power cable (1) from the control panel of the Comfort to the tractor cab socket.



DANGER

Ensure that the tractor is turned off and the key is removed from the ignition.

- Ensure the cable is not crushed by the tractor's rear window. Fasten the cable properly so that it is not pinched during turns or lifting.
8. Hydraulic brakes, single line (if installed): Connect the seed drill brake line to the tractor brake coupling.
 - There is no colour-coding on the hose.
 9. Pneumatic brakes, dual line (if installed): Connect the seed drill palm couplings to the tractor brake couplings.
 - The palm couplings are colour-coded.
 - Yellow = control
 - Red = feed
 10. If necessary, straighten the machine according to the instructions in section [5.3.3 Adjusting the lengthwise level of the machine with a turnbuckle](#) or [5.3.4 Adjusting the lengthwise level of the machine with a drawbar cylinder](#).

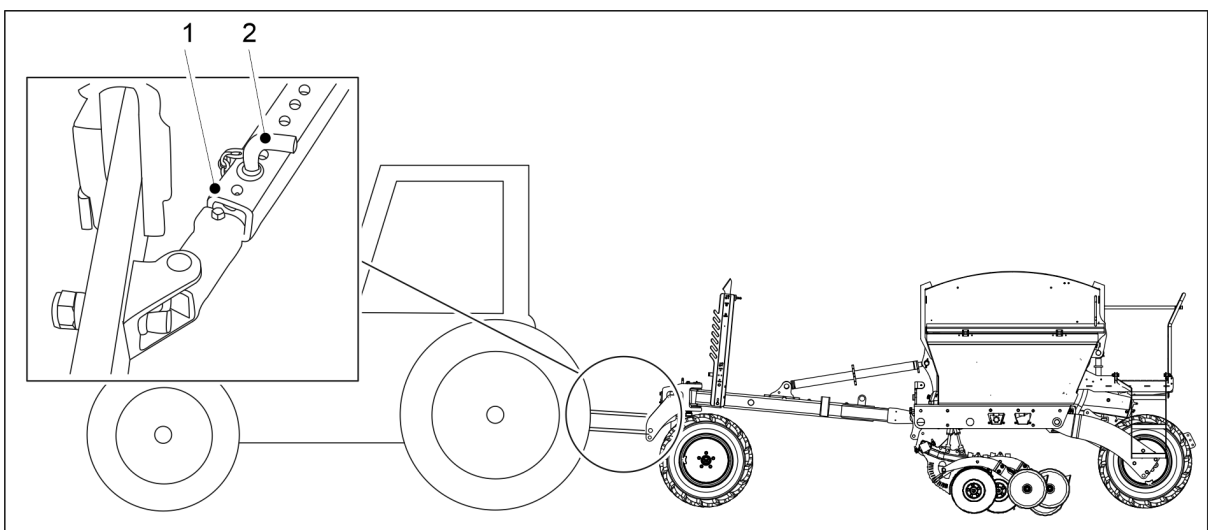

Figure. 5.3 - 95. Side limiters of the tractor link arms

11. Lock the side limiters (1) of the tractor link arms by inserting the pin (2) to the appropriate hole so that the link arm does not touch the tyres.
12. Open the machine lifting circuit ball valve according to the instructions in section [5.3.5 Using the machine lifting circuit ball valve](#).
13. Ensure the steerability of the tractor in accordance with the instructions in section [5.3.7 Ensuring the steerability of the tractor](#).
14. When driving on a field for the first time, set the middle markers according to the instructions given in section [5.3.8 Adjusting the middle markers](#).

5.3.1 Adjusting the wheel packer boom length

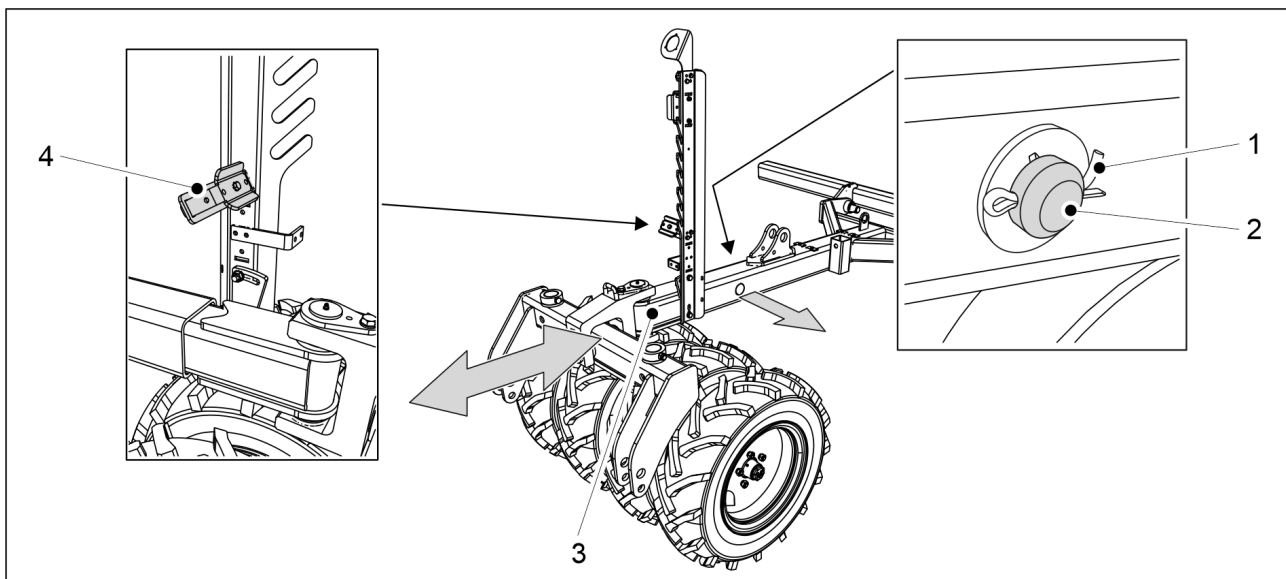

Figure. 5.3.1 - 96. Adjusting the length of the boom

1. Remove the cotter (1) of the boom mounting pin (2) and pull the mounting pin out of the boom.
2. Adjust the length of the boom (3) so that it is appropriate for the tractor.
 - The boom has three adjustment position at 200 mm intervals. The maximum length adjustment is 400 mm.
When adjusting the drawbar length, you can remove the lower hose clamp (4), which makes it easier to position the hydraulic hoses.
3. Insert the mounting pin in the boom and lock it in place with the cotter.

5.3.2 Using the ground support

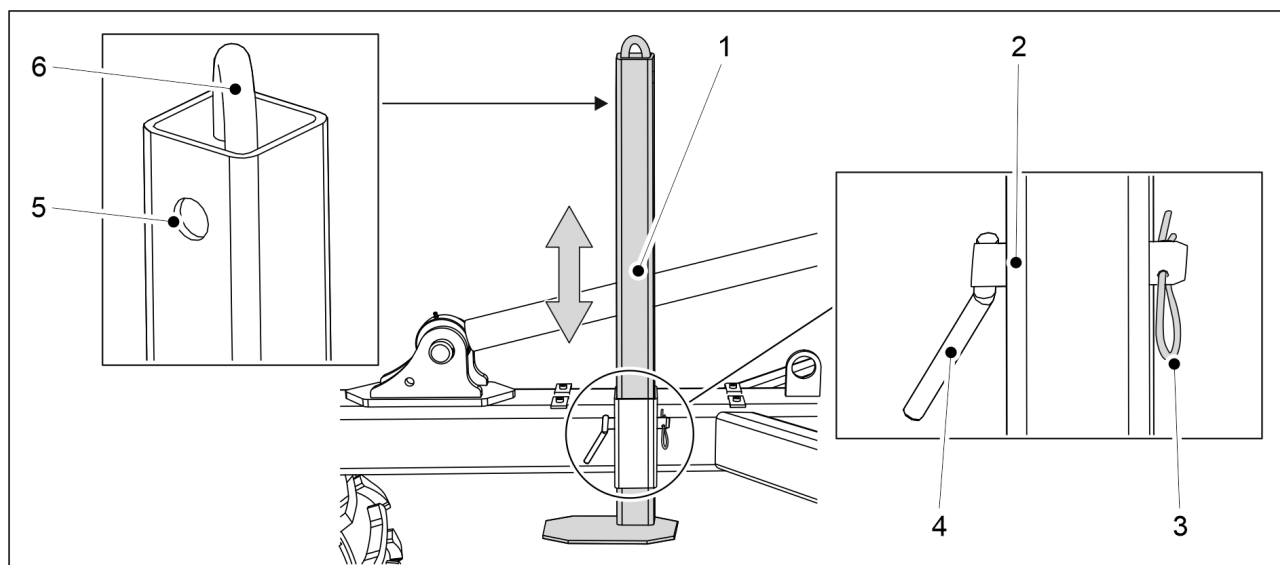

Figure. 5.3.2 - 97. Ground support

1. Remove the cotter pin (3) from the ground support (1) mounting pin (4).
2. Pull the mounting pin out of the ground support.
3. Move the ground support up or down by the lever (6).
4. Choose a mounting hole.
 - Hole (2) = Ground support lower position
 - Hole (5) = Ground support transportation position
5. Insert the mounting pin into the hole and lock in place with the cotter pin.

5.3.3 Adjusting the lengthwise level of the machine with a turnbuckle

- Perform the adjustment when the machine is on a level surface.

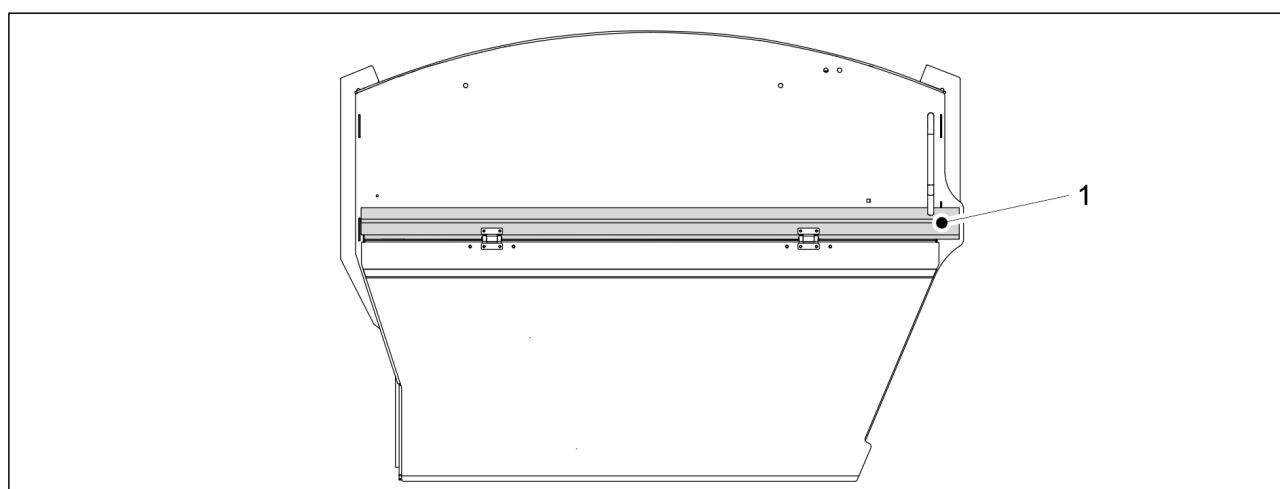

Figure. 5.3.3 - 98. Lengthwise level

- The machine is level when the sidebar (1) of the machine is horizontal.
Connect the seed drill to the tractor in accordance with section [5.3 Connecting to tractor](#).

1. Lower the machine by using the tractor hydraulics.
2. Switch off power in the tractor, remove the key from the ignition and engage the parking brake.

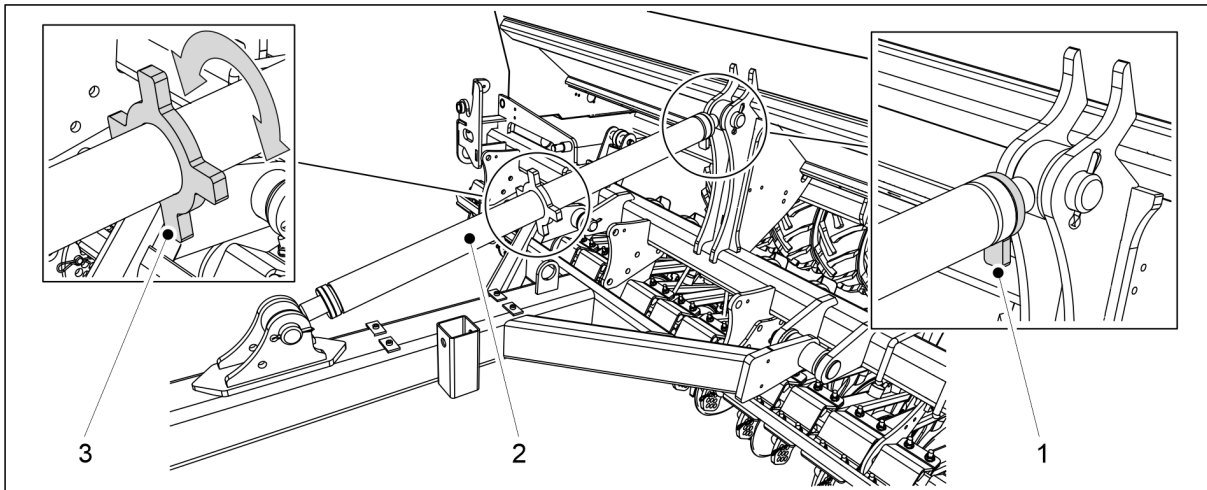

Figure. 5.3.3 - 99. Adjustment with a turnbuckle

3. Open the turnbuckle (2) lock by turning the lock (1).
4. Adjust the turnbuckle by turning the shaft (3) and visually ensure that the machine is level.
5. When the machine is level, tighten the turnbuckle lock.

5.3.4 Adjusting the lengthwise level of the machine with a drawbar cylinder

- Connect the seed drill to the tractor before adjusting the lengthwise level in accordance with section [5.3 Connecting to tractor](#). The tractor should be on during the adjustment. Perform the adjustment when the machine is on a level surface.

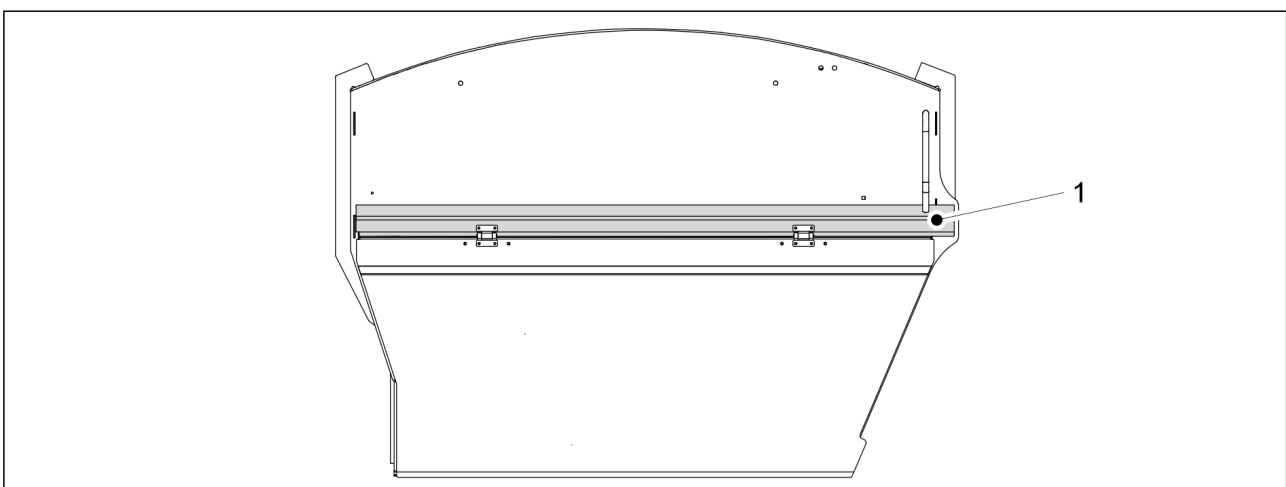

Figure. 5.3.4 - 100. Lengthwise level

- The machine is level when the sidebar (1) of the machine is horizontal.

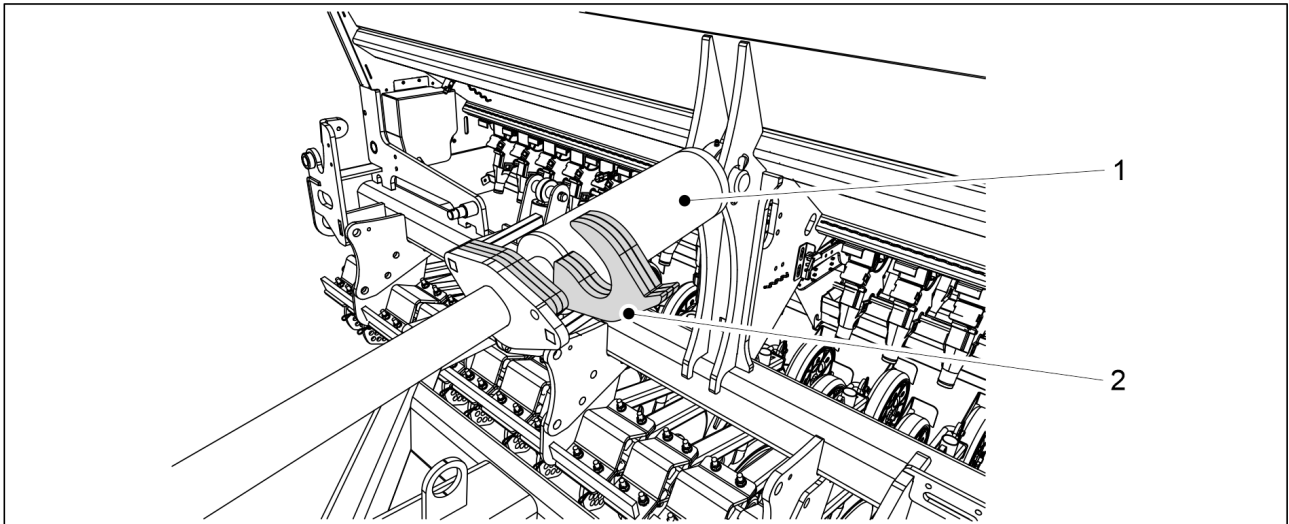

Figure. 5.3.4 - 101. Cylinder adjustment slats

1. Turn slats (2) over the cylinder (1) shaft.
2. Carefully run the cylinder against the slats and check visually that the machine is straight.
 - If needed, extend the cylinder and add or remove slats, if needed, until the machine is level.

5.3.5 Using the machine lifting circuit ball valve

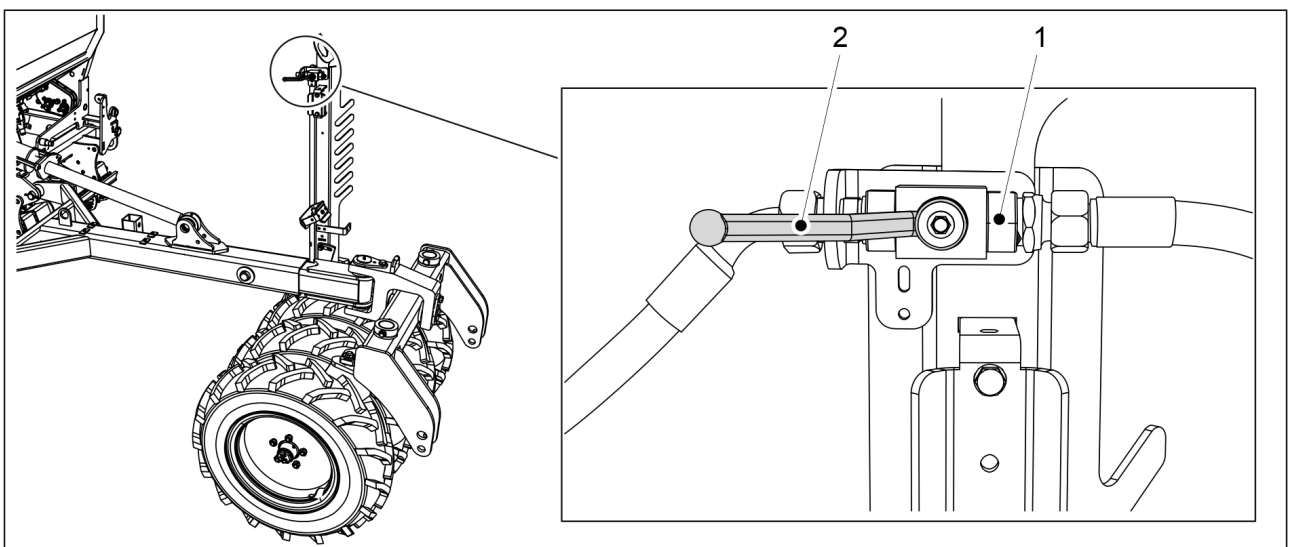

Figure. 5.3.5 - 102. Opening the lifting circuit ball valve

1. Open the machine's lifting circuit ball valve (1) after moving the machine into its working position.
 - The ball valve is closed when the handle (1) is in line with the ball valve.

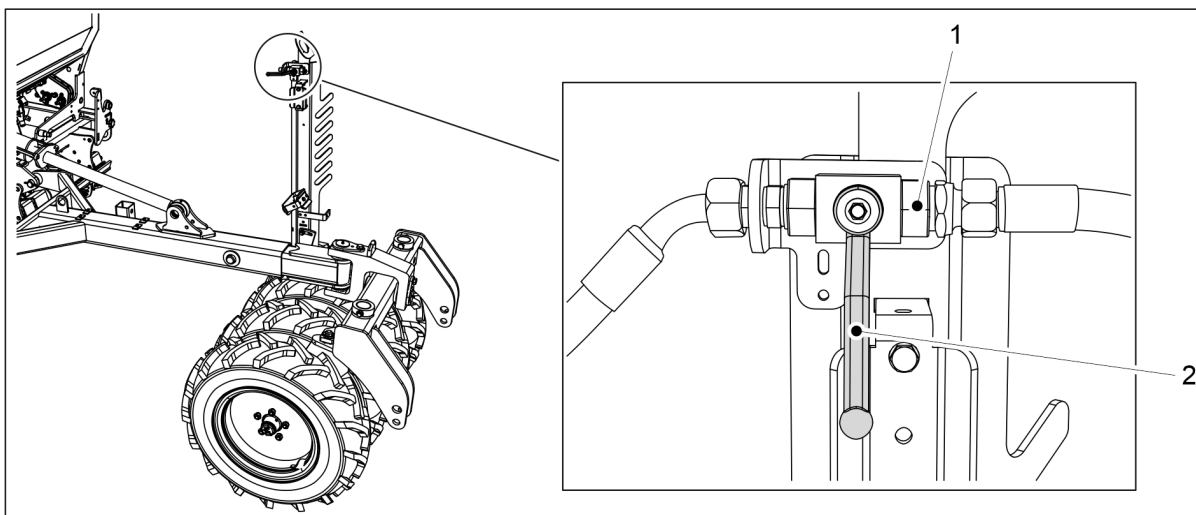

Figure. 5.3.5 - 103. Closing the lifting circuit ball valve

2. Close the lifting circuit ball valve (1) before starting out and performing maintenance.
 - The ball valve is closed when the handle (2) is perpendicular to the ball valve.

5.3.6 Using the transport wheels centre axle lift ball valve

- These instructions only apply to the FORTE 400 EVO seed drill with a brake system.

The ball valve is located in the upper part of the hose rack, which is attached to the top of the machine's transport wheels.

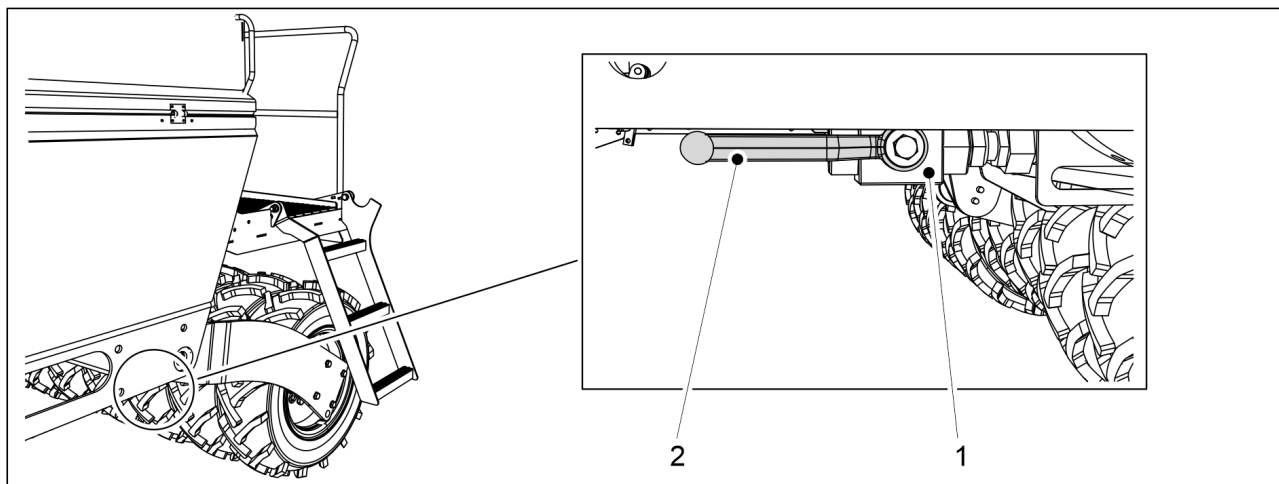

Figure. 5.3.6 - 104. Ball valve open

1. Open the transport wheels centre axle lift ball valve (1) when putting the machine into its transport position.
 - The ball valve is closed when the handle (2) is in line with the ball valve. In this case, the centre axle lift is operational.

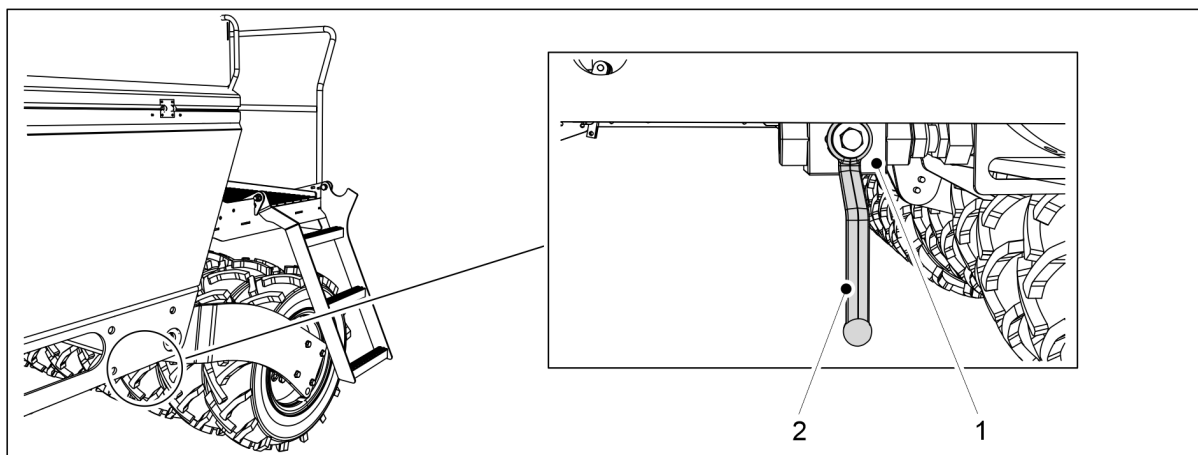

Figure. 5.3.6 - 105. Ball valve closed

2. Close the transport wheels centre axle lift ball valve (1) when putting the machine into its working position.
 - The ball valve is closed when the handle (2) is perpendicular to the ball valve. In this case, the centre axle lift is not operational.

5.3.7 Ensuring the steerability of the tractor

The calculation of the stability of the tractor - seed drill combination is provided in the attachment *Calculating the stability of the tractor - seed drill combination*. The steering response of a small tractor may be compromised when it pulls the seed drill, because some of the weight of the seed drill rests on the tractor's rear axle. If steering response is weak, we recommend the use of front weights on the tractor. The tractor's weight transfer system should also be switched off, since when using the weight control system, the height of the lifting device may change based on the load and impact the seeding depth.

5.3.8 Adjusting the middle markers

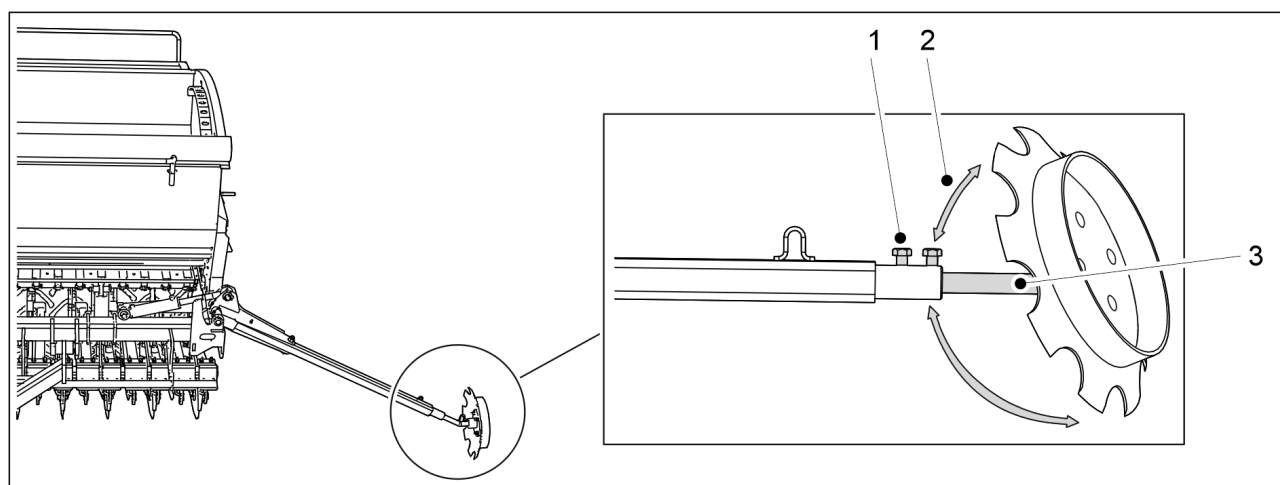

Figure. 5.3.8 - 106. Adjusting the middle markers

1. Loosen the two screws (1).
2. Adjust the toe-in (2) by rotating the disc around the axle (3).

- The middle marker should plough a furrow deep enough to be visible in the ground.
The distance between the centre line of the seed drill and the furrow made by the middle marker should be 3 metres on the FORTE 300 EVO and 4 metres on the FORTE 400 EVO. However, the adjustment is indicative. Check the adjustment in the field to avoid seeding overlaps and 6.18 Securing the position of the middle markers stripes. Seeding overlaps and stripes may occur if the operator sits at an angle in the tractor, for example.

3. Adjust the width of the marker axle (3).

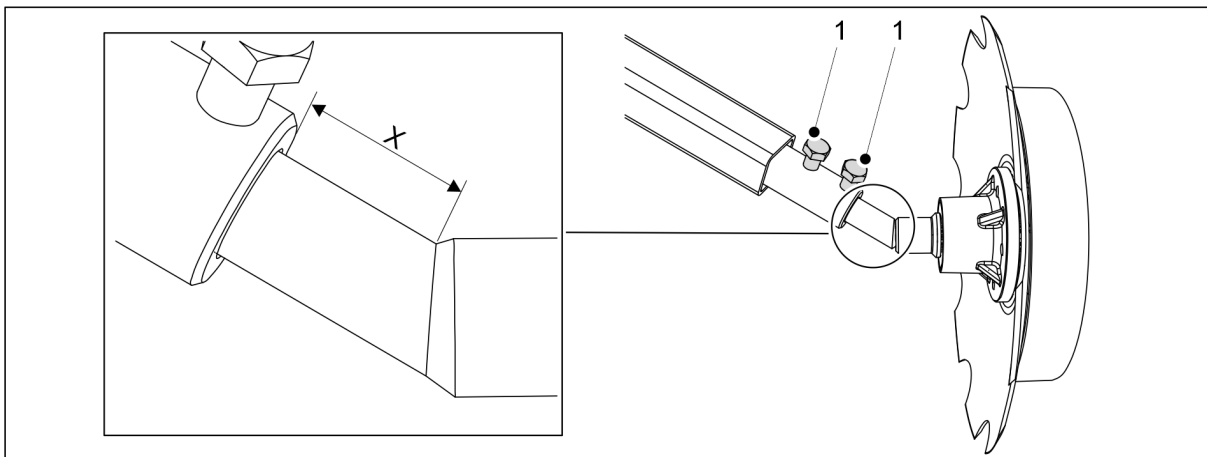

Figure. 5.3.8 - 107. Default width adjustment measurement

- FORTE 300 EVO: X = 50 mm
FORTE 400 EVO: X = 180 mm
The measurements are indicative.

4. Tighten the two screws (1).

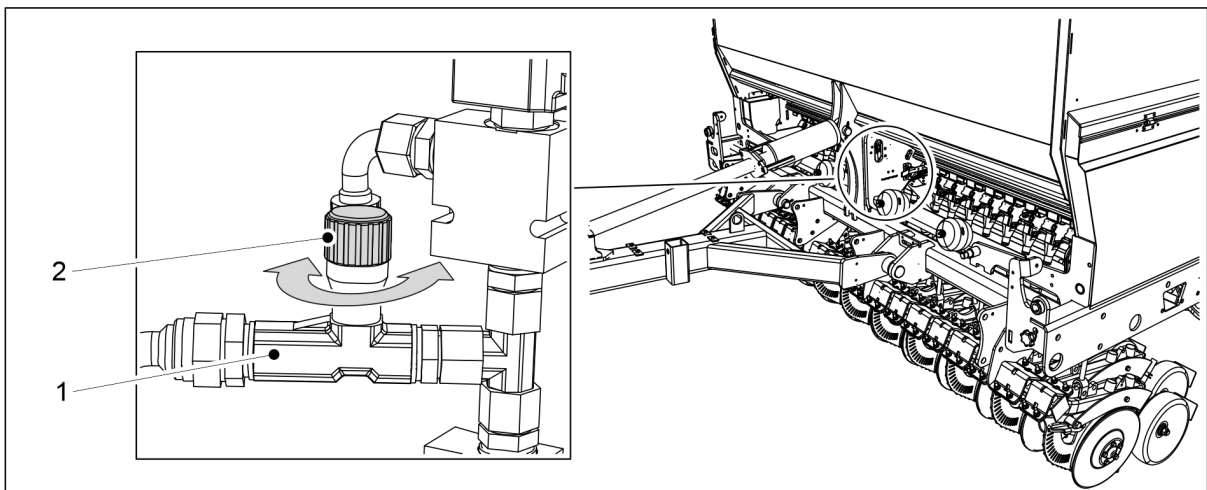

Figure. 5.3.8 - 108. Adjusting the lifting speed of the middle markers

5. Adjust the lifting speed of the middle markers by turning the restrictor valve (1) knob (2).
- Turn the knob clockwise to reduce the speed.
Turn the knob counterclockwise to increase the speed.

5.3.9 Adjusting the width of the rear markers

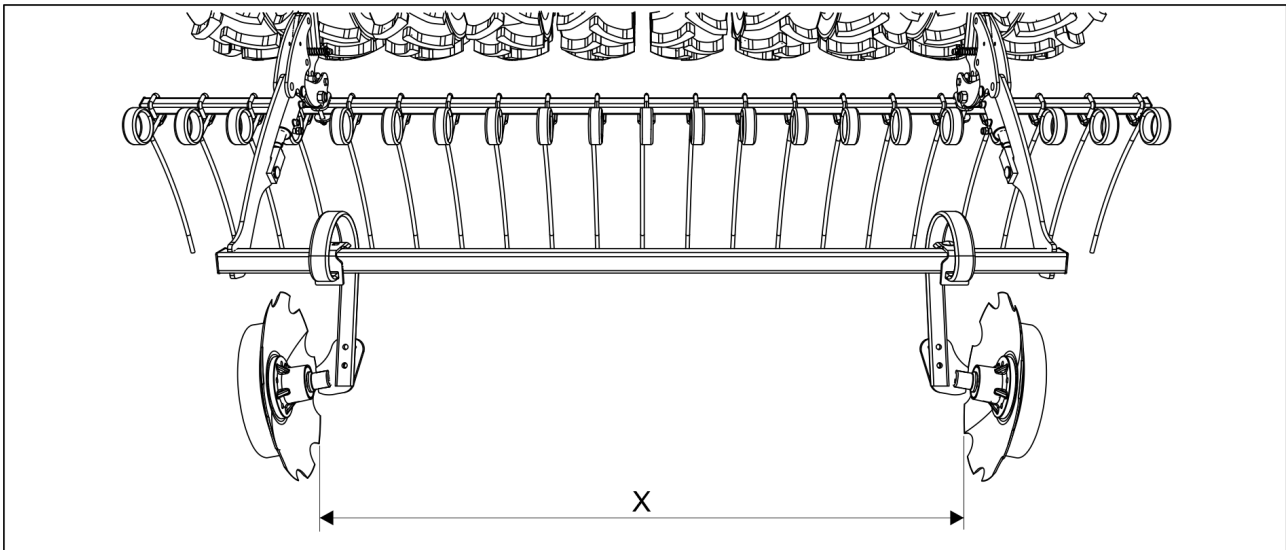

Figure. 5.3.9 - 109. Adjusting the width of the rear markers

1. Adjust the disc spacing - measurement X - according to the tramline track width.
 - The possible tramline track widths are presented in section [1.2 Specifications](#).

6 Machine adjustment and use

6.1 Rendering the machine to the transport position

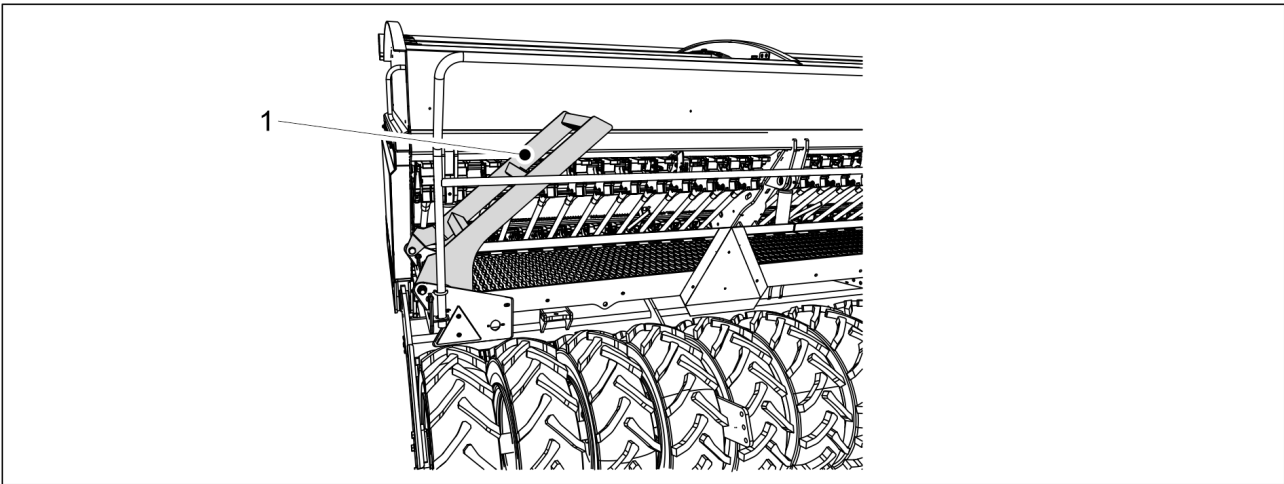

Figure. 6.1 - 110. Working platform stairs

1. Fold the working platform stairs (1) up.
 - When raised, the stairs will be at an approximately 40 degree angle to the working platform.
2. Open the transport wheels centre axle lift ball valve in accordance with section [5.3.6 Using the transport wheels centre axle lift ball valve](#).
 - These instructions apply only to FORTE 400 EVO equipped with a braking system.
3. Raise the machine with the tractor hydraulics.
4. If the machine is equipped with middle markers, ensure that the middle markers have settled into their transport position and their ball valves are closed in accordance with section [3.4 Using the middle marker ball valves](#).
5. Close the machine lifting circuit ball valve in accordance with section [5.3.5 Using the machine lifting circuit ball valve](#).
6. Check the tyre pressure in accordance with section [7.1.3 Checking tyre pressure](#).
7. Ensure that the machine is clean.
 - If necessary, clean the machine in accordance with section [7.3 Cleaning](#).
8. Visually check that the bolts of the transport wheels are tight in accordance with section [7.1.2.1 Checking the tightness of the wheel bolts of the transport wheels](#) and tighten if necessary.
9. Check that the bolts of the bearings are tight in accordance with section [7.1.2.2 Checking the tightness of the bolts in the flange bearings of the transport wheels](#) and tighten if necessary.
10. If the machine is equipped with a standard drawbar, visually check that the bolts of the towing device are tight in accordance with section [7.1.2.6 Checking the tightness of the towing eye bolts](#) and tighten if necessary.

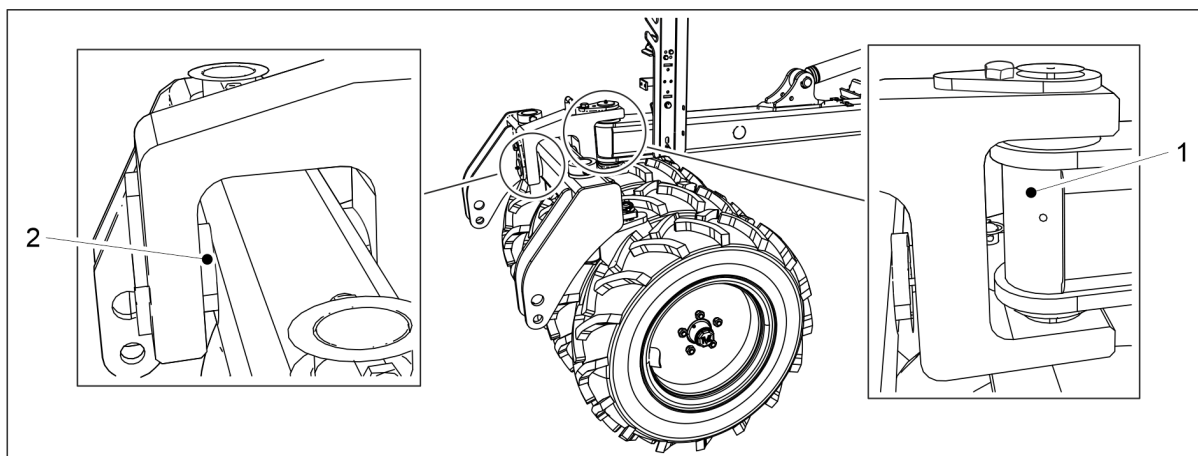

Figure. 6.1 - 111. Wheel packer pins

11. If the machine is equipped with a wheel packer, visually check that the wheel packer pins (1, 2) are closed.
12. If the seed drill is equipped with a standard drawbar, ensure that the tractor hitch is engaged and locked.
13. If the seed drill is equipped with a wheel packer, ensure that the tractor's link arms are locked to the wheel packer.

6.2 Rendering the machine to the working position

1. Ensure that the tractor valve connected to the lifting circuit is not in the floating position.
2. Open the machine lifting circuit ball valve in accordance with section [5.3.5 Using the machine lifting circuit ball valve](#).
3. Close the transport wheels centre axle lift ball valve in accordance with section [5.3.6 Using the transport wheels centre axle lift ball valve](#).
 - These instructions apply only to FORTE 400 EVO equipped with a braking system.
4. If the machine is equipped with middle markers, open the middle marker ball valves in accordance with section [3.4 Using the middle marker ball valves](#).

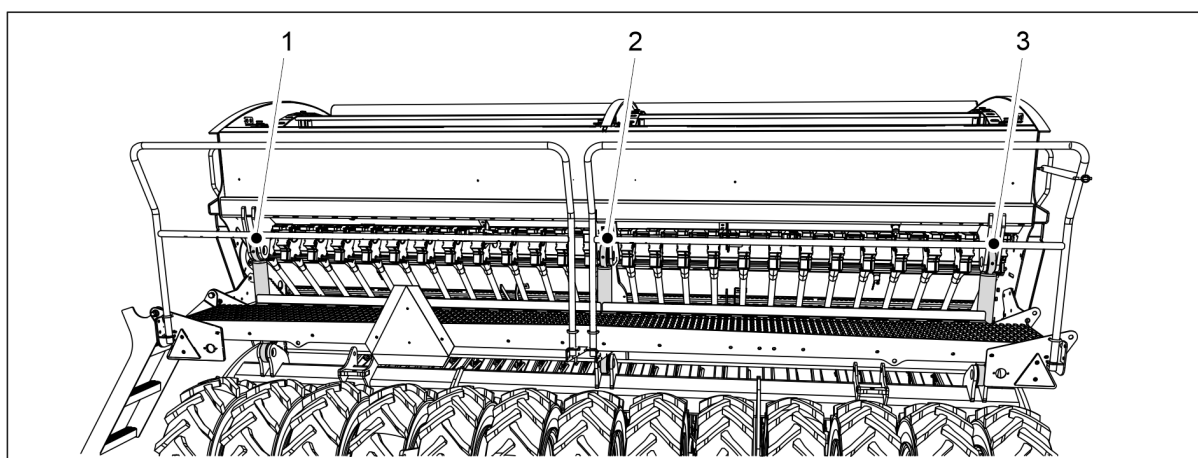

Figure. 6.2 - 112. Lifting cylinder

5. Lower the lifting cylinders to their lower position using the tractor hydraulics.
 - The FORTE 300 EVO has 1 lifting cylinder (2). The FORTE 400 EVO has 3 lifting cylinders (1-3).

6.3 Comfort control system user settings

- If you start the control system when the machine is in its working position, lift and lower the machine using the tractor's hydraulics before starting/resuming work. This will ensure that the user settings are implemented.

6.3.1 Active operating mode

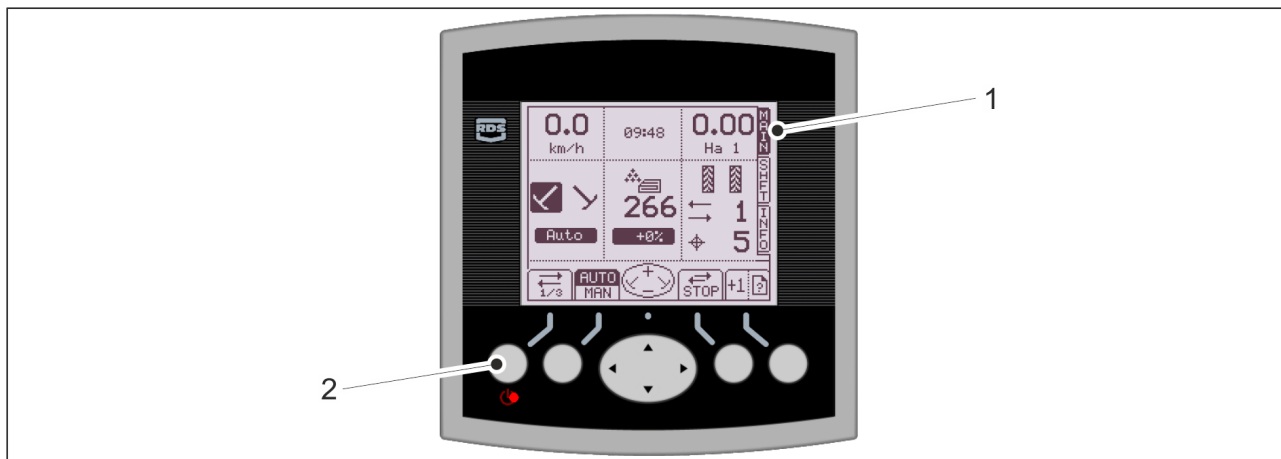

Figure. 6.3.1 - 113. Active operating mode

- Select the desired active operating mode (3 options) on the MAIN screen (1) by pressing the controller power button (2). Normal mode is the default operating mode.

Normal status

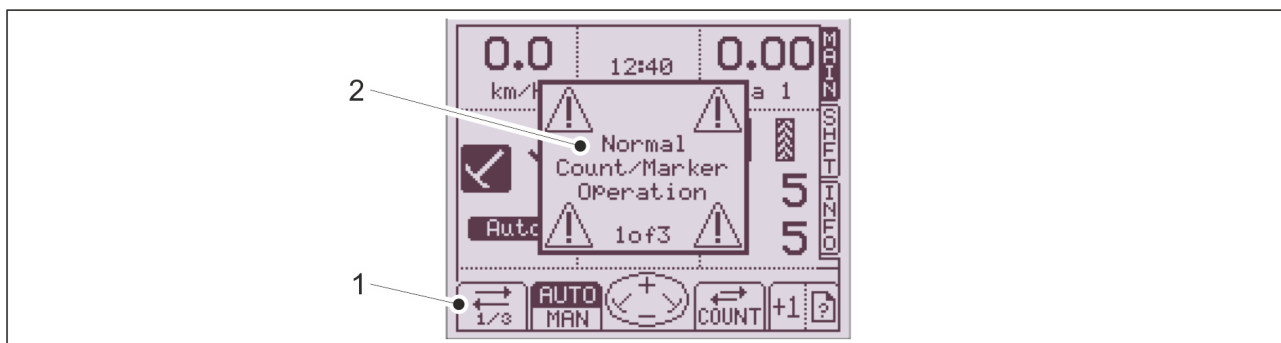

Figure. 6.3.1 - 114. Normal status

- In Normal mode, the machine and middle markers operate normally. The counters and switching of the middle marker side are operational whenever lifting. The function screen number (1) is shown in the bottom left corner of the user interface. The function info box (2) flashes on the screen when entering Normal mode.

Lift inhibit mode

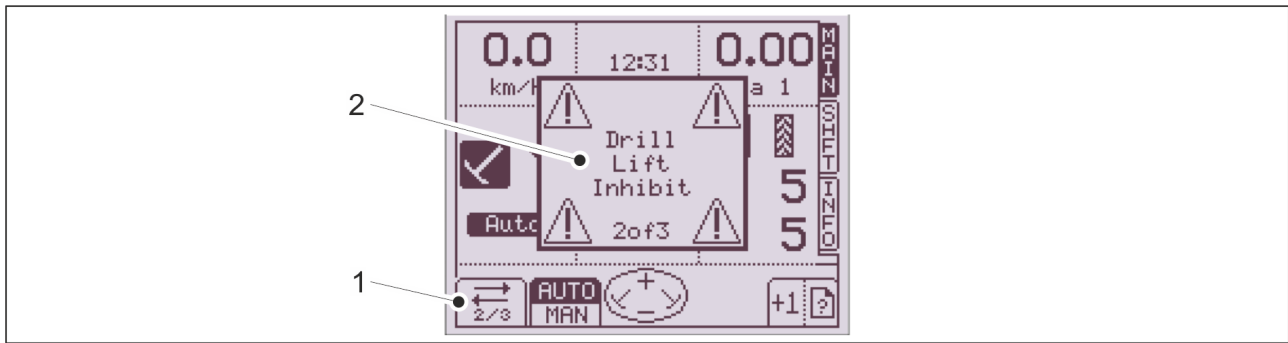

Figure. 6.3.1 - 115. Lift inhibit mode

- The machine remains in seeding position but the middle markers are lifted. This function is used when the operator wants to avoid an obstacle in front of the middle markers during operation. The function screen number (1) is shown in the bottom left corner of the user interface. The function info box (2) also flashes on the screen.

Counter stop mode

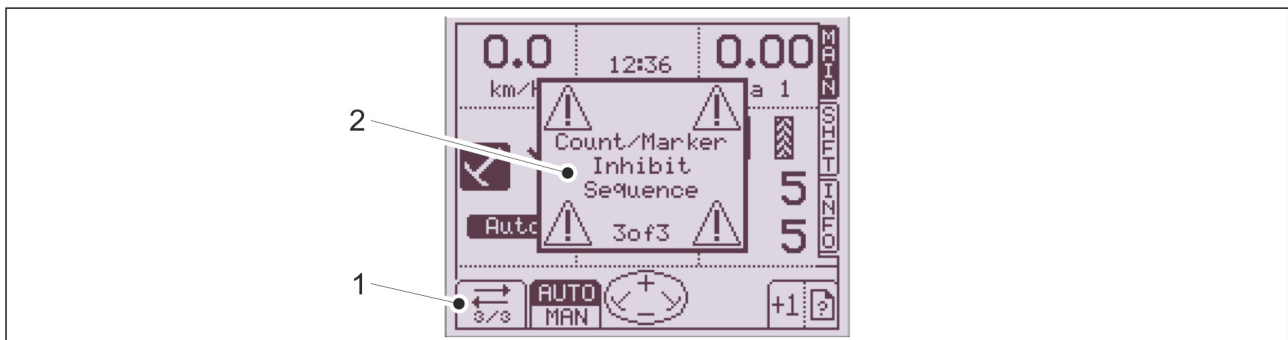

Figure. 6.3.1 - 116. Counter stop mode

- Corresponds with the Stop tramlines function. See instruction [6.3.3.2 Tramline counter hold](#). The tramline counter is shut off. The automatic switching of middle marker sides is not in use. Used when filling if the machine must be lowered. The function screen number (1) is shown in the bottom left corner of the user interface. The function info box (2) also flashes on the screen.

6.3.2 Using middle markers

6.3.2.1 Selecting automatic and manual mode

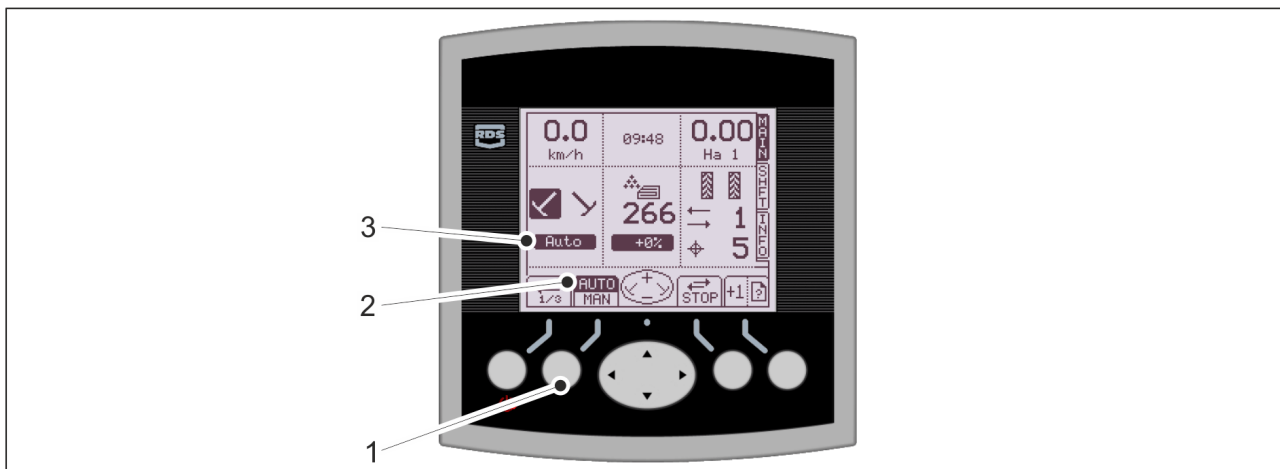

Figure. 6.3.2.1 - 117. Selecting automatic and manual mode for middle markers

1. Change the middle marker function by pressing the AUTO-MAN key (1).
 - The middle marker mode appears on the screen highlighted (2) and (3).

6.3.2.2 Selecting middle markers

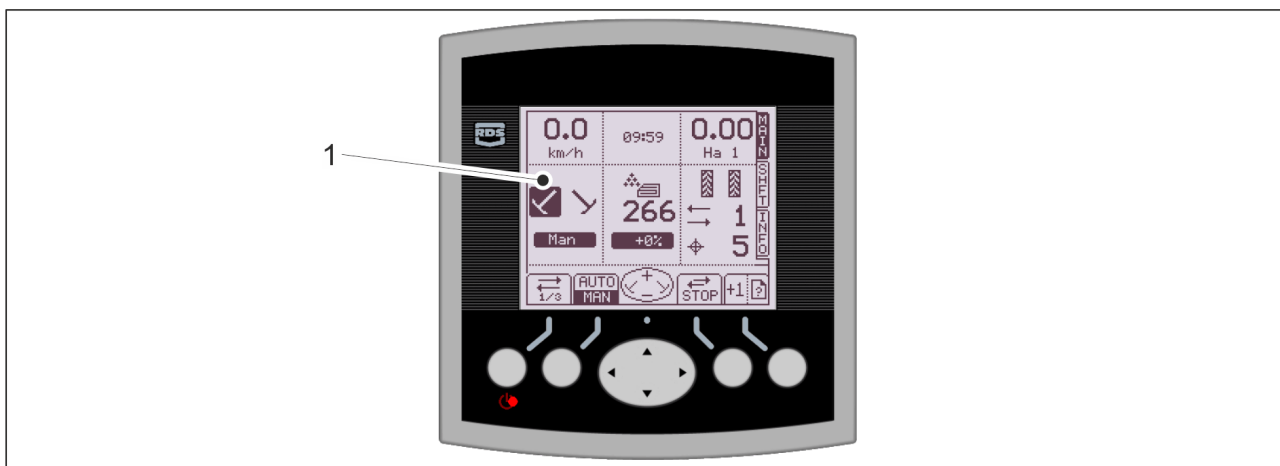

Figure. 6.3.2.2 - 118. Selecting middle markers

1. Select a middle marker using the arrow keys.
 - Press the left arrow key to activate the left middle marker. Press the right arrow key to activate the right middle marker. The active middle marker appears highlighted (1) on the screen.
In Automatic mode, the middle marker automatically switches the side when reaching the edge of the field. In Manual mode, the middle marker is turned on and off using the arrow keys.

6.3.3 Using the tramline counter

6.3.3.1 Tramline counter correction

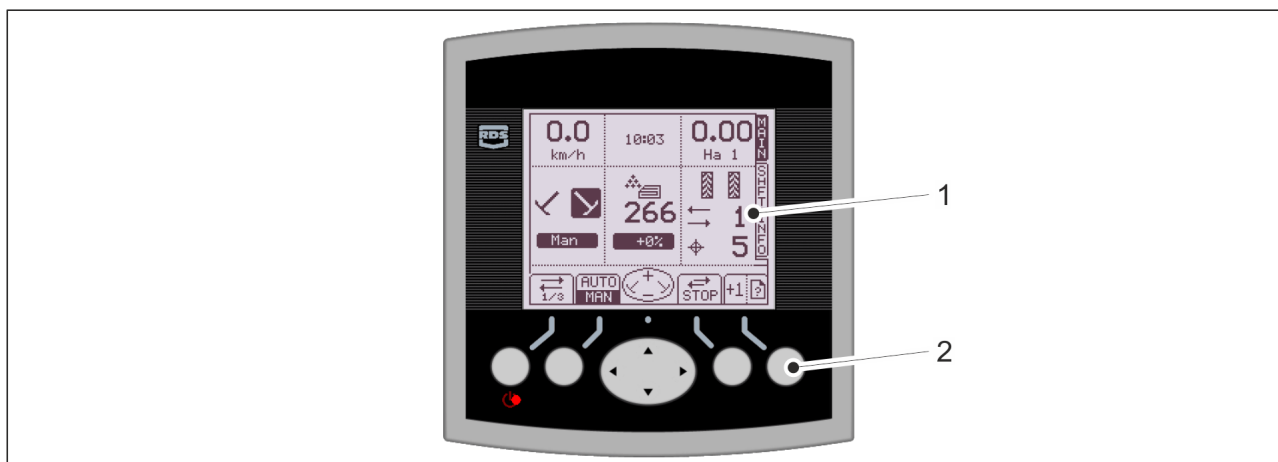

Figure. 6.3.3.1 - 119. Tramline counter correction

- Press the ADD TRAMLINE COUNTER key (2) to add a tramline (1) on drive-around runs or subtract a tramline (1) on back-and-forth runs, if the machine is unintentionally raised one too many times.

1. Press the ADD TRAMLINE COUNTER key.
2. To subtract a tramline, press the ADD TRAMLINE COUNTER key several times in a row until you reach the desired number of tramlines.
 - The tramline number first increases and then start from 1 again.

6.3.3.2 Tramline counter hold



Figure. 6.3.3.2 - 120. Tramline counter hold

- The tramline counter can be stopped when work is interrupted and when filling the machine. The tramline counter can be stopped when the lift inhibit function is in normal mode (1/3). See instruction [6.3.1 Active operating mode](#).

1. Press the STOP TRAMLINE COUNTER key (1) to stop the tramline counter

6.3.4 Setting the fertiliser target rate

- Adjusting of fertiliser target rate is optional.



Figure. 6.3.4 - 121. Setting the fertiliser target rate

- The fertiliser target rate (1) is set on the SHFT screen.
1. Press the SET key (2).
 - The first number starts to flash.
 2. Change the value by pressing the up/down arrow keys.
 3. Confirm the value by pressing right arrow key.
 4. Repeat steps 2-3 for the other numbers.



Figure. 6.3.4 - 122. Confirming the fertiliser target rate

5. Confirm the fertiliser target rate by pressing the OK key (1).

6.3.5 Selecting the remote control mode



Figure. 6.3.5 - 123. Changing the adjusting of fertiliser target rate

1. Change the adjusting of fertiliser target rate (1) by pressing the arrow keys.
 - Press the up arrow key to increase the fertiliser target rate by the set step (default 5%). Press the down arrow key to decrease the fertiliser target rate by the set step (default 5%). The change in rate is displayed as a percentage (2) on the screen. Instructions on setting the step are provided in section [4.1.4.2 Adjusting the fertiliser target rate step](#).
2. If the fertiliser target rate does not decrease when pressing the arrow key, go to lift inhibit mode on the Main screen (see instruction [6.3.1 Active operating mode](#)) and then return to adjust the target rate.

6.3.6 Using the area counters

The Comfort control system has two counters for measuring area: Ha1 and Ha2. During operation, the values in both counters increase, regardless of whether either counter is active on the Main screen.

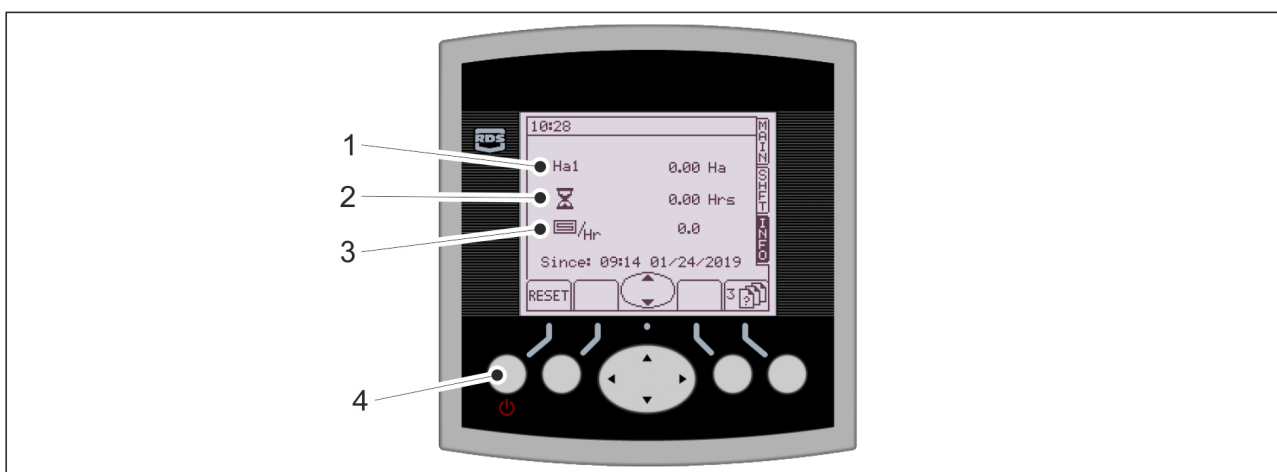

Figure. 6.3.6 - 124. Resetting area counters

- The area seeded (1), seeding time (2) and average work performed (3) are displayed on the screen. Use the up/down arrow buttons to select information on each field (Ha1, Ha2 and total machine quantity). The total quantity cannot be reset.

1. Reset the field by pressing the RESET button (4).



Figure. 6.3.6 - 125. Confirming the resetting of area counters

2. Confirm the reset by pressing the YES button (1).

6.4 Feeders

The feeders are powered by the machine's left running gear via a chain.

The fertiliser and seed feed rates are adjusted by means of control levers on the left-hand transmission of the machine. The small seed rate is adjusted by means of a control lever on the right hand transmission of the machine.

In each feeder, there a shut-off plate between the feeder chamber and the hopper to completely shut off the feed of the feeder, if necessary. This allows seeding with incomplete working width or, for example, increasing row spacing by seeding with only every second coulter.

6.5 Seeding quantities

The seeding tables that contain the basic values for adjusting the seeding quantity are located under the transmission cover in the seed drill. The seeding tables for different varieties are presented below.

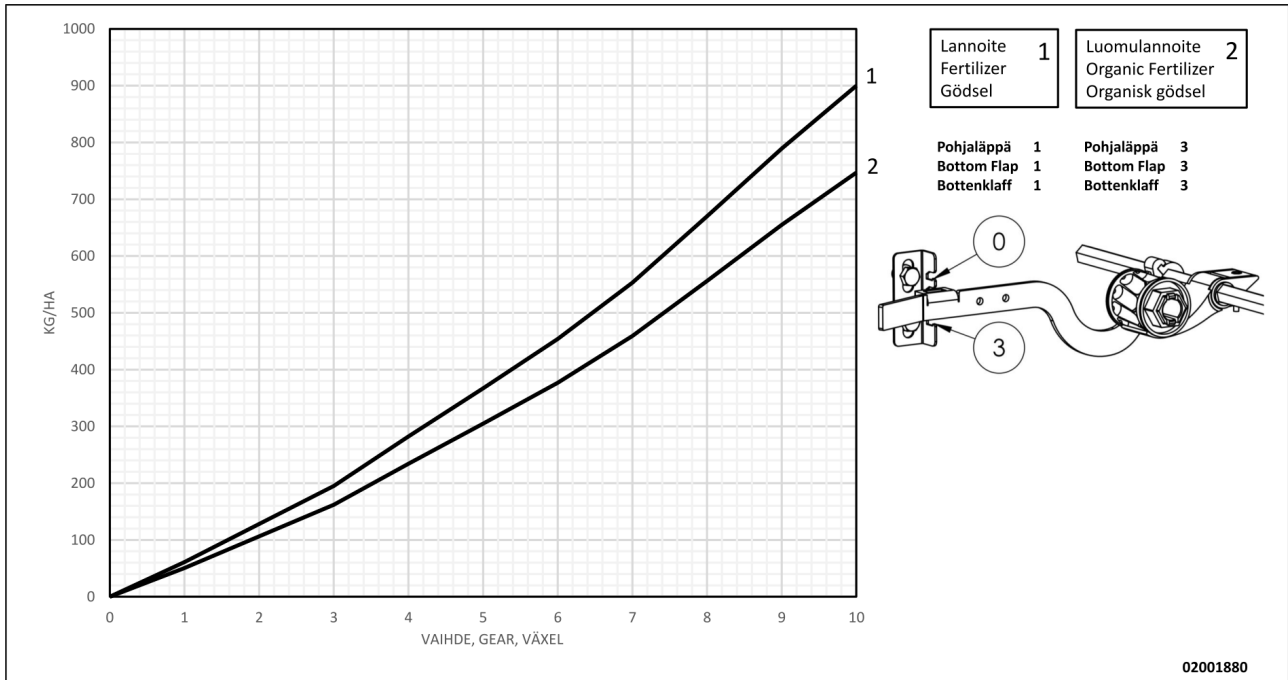

Figure. 6.5 - 126. Seeding table for fertiliser

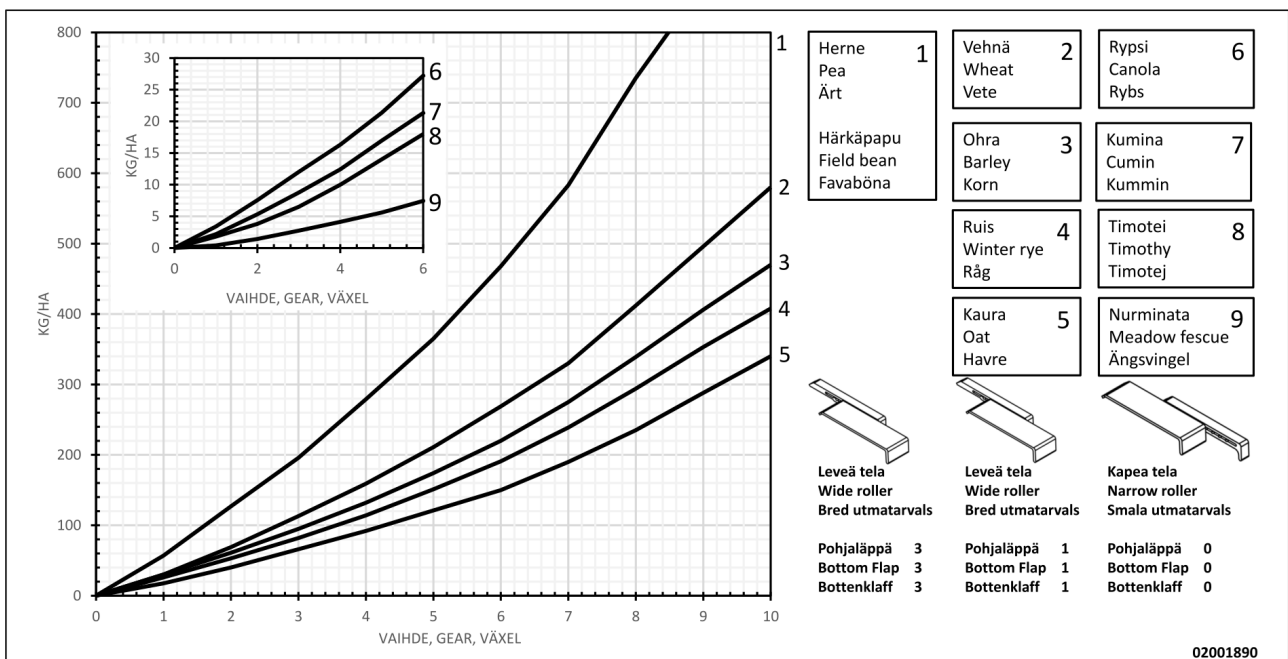

Figure. 6.5 - 127. Seeding table for seed

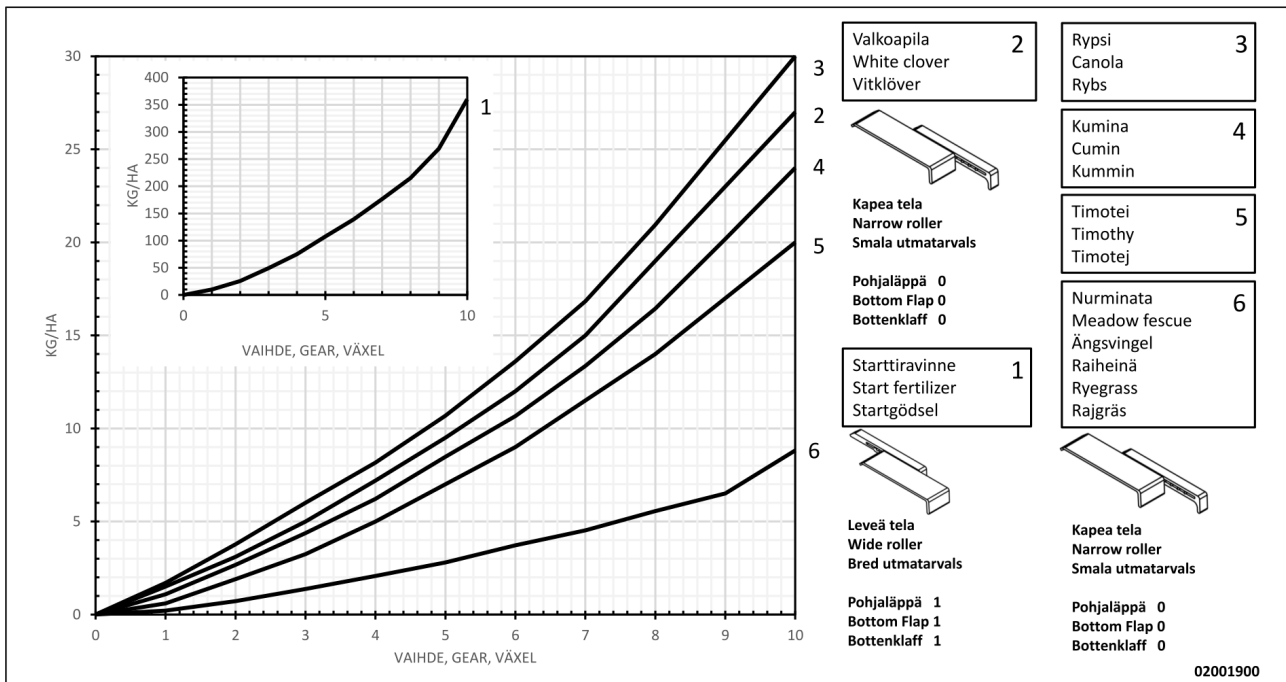

Figure 6.5 - 128. Seeding table for small seed

6.6 Preparations preceding hopper filling

6.6.1 Preparations preceding fertiliser hopper filling

1. Ensure that the stability of the tractor and seed drill combination has been calculated.
 - The calculation of the stability is provided in the attachment *Calculating the stability of the tractor - seed drill combination*.
2. Check that the fertiliser hopper is empty, clean and dry.
 - If needed, clean the hopper in accordance with section [7.3.1 Cleaning the hoppers](#).
3. Check that the hopper divider is in the desired position.
 - If the machine is equipped with a small seed hopper, if necessary adjust the divider as instructed in section [6.6.4 Adjusting the hopper divider on a machine with a small seed hopper](#).
 If the machine is not equipped with a small seed hopper, if necessary adjust the divide as instructed in section [6.6.5 Adjusting the hopper divider on a machine with no small seed hopper](#).
4. Adjust the fertiliser feed rate as instructed in section [6.6.6 Adjusting the feeding quantity with the gearbox control lever](#).
5. Adjust the position of the bottom flap of the feeder units in accordance with section [6.6.7.1 Adjusting the bottom flap position](#).
6. Adjust the position of the shut-off plates of the feeder units in accordance with section [6.6.7.2 Adjusting the shut-off plate position](#).

6.6.2 Preparations preceding seed hopper filling

1. Ensure that the stability of the tractor and seed drill combination has been calculated.

- The calculation of the stability is provided in the attachment *Calculating the stability of the tractor - seed drill combination*.
2. Check that the seed hopper is empty, clean and dry.
 - If needed, clean the hopper in accordance with section [7.3.1 Cleaning the hoppers](#).
 3. Check that the hopper divider is in the desired position.
 - If the machine is equipped with a small seed hopper, if necessary adjust the divider as instructed in section [6.6.4 Adjusting the hopper divider on a machine with a small seed hopper](#).
If the machine is not equipped with a small seed hopper, if necessary adjust the divide as instructed in section [6.6.5 Adjusting the hopper divider on a machine with no small seed hopper](#).
 4. Adjust the seed feed rate as instructed in section [6.6.6 Adjusting the feeding quantity with the gearbox control lever](#).
 5. Adjust the position of the bottom flap of the feeder units in accordance with section [6.6.8.1 Adjusting the bottom flap position](#).
 6. Adjust the position of the shut-off plates of the feeder units in accordance with section [6.6.8.2 Adjusting the shut-off plate position](#).

6.6.3 Preparations preceding small seed filling

1. Ensure that the stability of the tractor and seed drill combination has been calculated.
 - The calculation of the stability is provided in the attachment *Calculating the stability of the tractor - seed drill combination*.
2. Ensure that the small seed hopper is empty, clean and dry.
 - If needed, clean the small seed hopper in accordance with the instructions in section [7.3.2 Cleaning of the small seed hopper](#).
3. Adjust the small seed feed rate as instructed in section [6.6.6 Adjusting the feeding quantity with the gearbox control lever](#).
4. Adjust the position of the bottom flap of the small seed hopper's feeder units in accordance with section [6.6.9.1 Adjusting the bottom flap position](#).
5. Adjust the position of the small seed hopper feeder units shut-off plates in accordance with section [6.6.9.2 Adjusting the shut-off plate position](#).
6. Choose the seeding method for small seeds as instructed in section [6.6.10 Selection of small seed seeding method](#).

6.6.4 Adjusting the hopper divider on a machine with a small seed hopper



DANGER

Before adjusting the divider, ensure that the hoppers are empty.

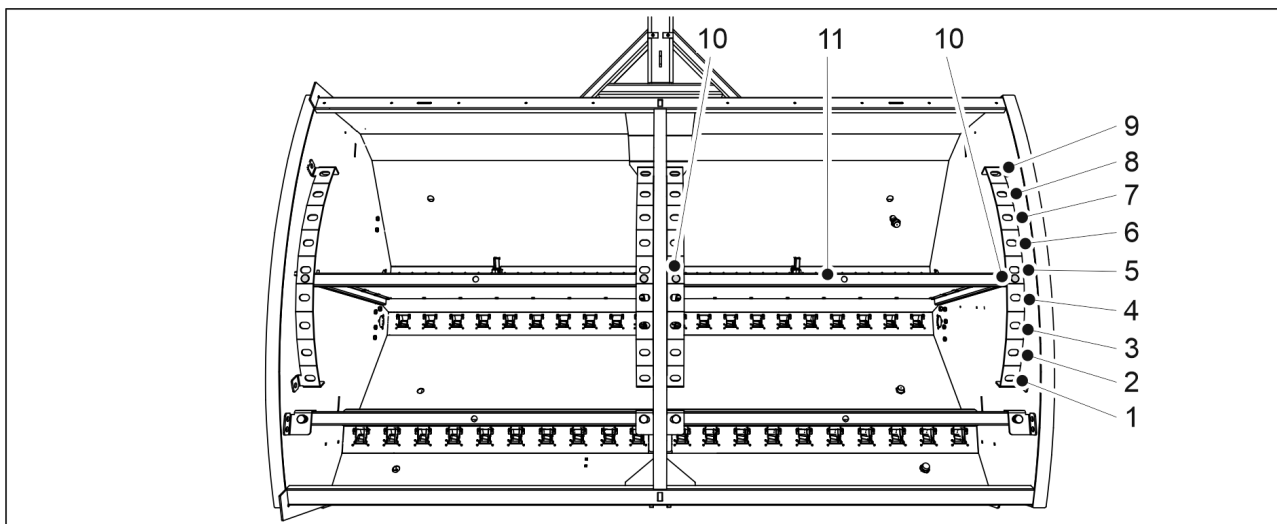

Figure. 6.6.4 - 129. Adjusting the hopper divider

1. Remove the two locking pins (10) of one side of the divider (11).
2. Push the divider to the appropriate position.
3. Reinsert the locking pins.
4. Adjust the other side.

Table. 6.6.4 - 18. Hopper volumes in different positions of the divider on FORTE 300 EVO with a small seed hopper

FORTE 300 EVO	Seed (L)	Fertiliser (L)	Small seed (l)	Total (L)
1.	1,030	2,400	370	3,800
2.	1,190	2,240	370	3,800
3.	1,340	2,090	370	3,800
4.	1,480	1,950	370	3,800
5.	1,630	1,800	370	3,800
6.	1,780	1,650	370	3,800
7.	1,930	1,500	370	3,800
8.	2,080	1,350	370	3,800
9.	2,230	1,200	370	3,800

Table. 6.6.4 - 19. Hopper volumes in different positions of the divider on FORTE 400 EVO with a small seed hopper

FORTE 400 EVO	Seed (L)	Fertiliser (L)	Small seed (l)	Total (L)
1.	1,450	3,340	510	5,300
2.	1,680	3,110	510	5,300
3.	1,890	2,900	510	5,300
4.	2,100	2,690	510	5,300
5.	2,300	2,490	510	5,300

6.	2,490	2,300	510	5,300
7.	2,690	2,100	510	5,300
8.	2,900	1,890	510	5,300
9.	3,120	1,670	510	5,300

6.6.4.1 Hopper volumes with the small seed hopper dividers turned backwards

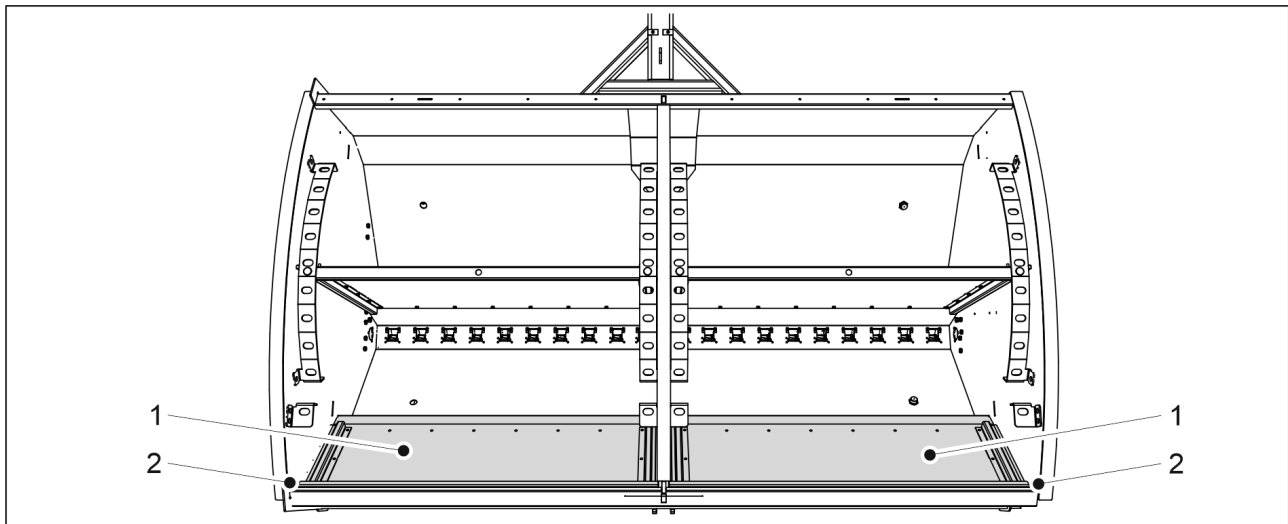

Figure. 6.6.4.1 - 130. Small seed hopper dividers turned backwards

- When the small seed hopper dividers (1) are turned backwards (2), the hopper volumes correspond to the hopper volumes given in chapter [6.6.5 Adjusting the hopper divider on a machine with no small seed hopper](#).

6.6.5 Adjusting the hopper divider on a machine with no small seed hopper



DANGER

Before adjusting the divider, ensure that the hoppers are empty.

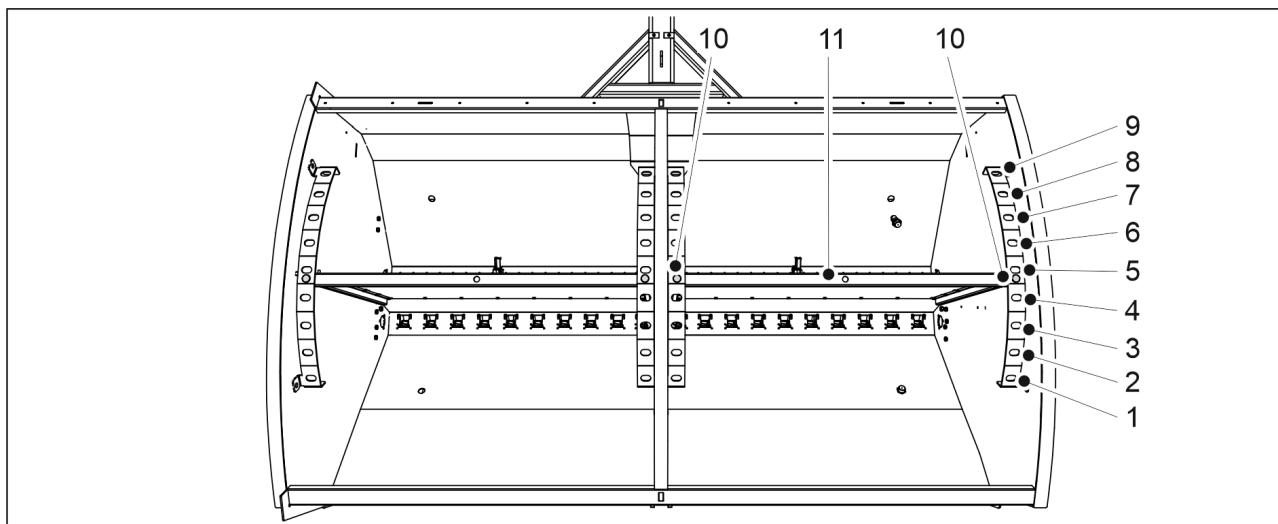

Figure. 6.6.5 - 131. Adjusting the hopper divider

1. Remove the two locking pins (10) of one side of the divider (11).
2. Push the divider to the appropriate position.
3. Reinsert the locking pins.
4. Adjust the other side.

Table. 6.6.5 - 20. Hopper volumes in different positions of the divider on FORTE 300 EVO with no small seed hopper

FORTE 300 EVO	Seed (L)	Fertiliser (L)	Total (L)
1.	1,400	2,400	3,800
2.	1,560	2,240	3,800
3.	1,710	2,090	3,800
4.	1,850	1,950	3,800
5.	2,000	1,800	3,800
6.	2,150	1,650	3,800
7.	2,300	1,500	3,800
8.	2,450	1,350	3,800
9.	2,600	1,200	3,800

Table. 6.6.5 - 21. Hopper volumes in different positions of the divider on FORTE 400 EVO with no small seed hopper

FORTE 400 EVO	Seed (L)	Fertiliser (L)	Total (L)
1.	1,960	3,340	5,300
2.	2,190	3,110	5,300
3.	2,400	2,900	5,300
4.	2,610	2,690	5,300
5.	2,810	2,490	5,300

6.	3,000	2,300	5,300
7.	3,200	2,100	5,300
8.	3,410	1,890	5,300
9.	3,630	1,670	5,300

6.6.6 Adjusting the feeding quantity with the gearbox control lever

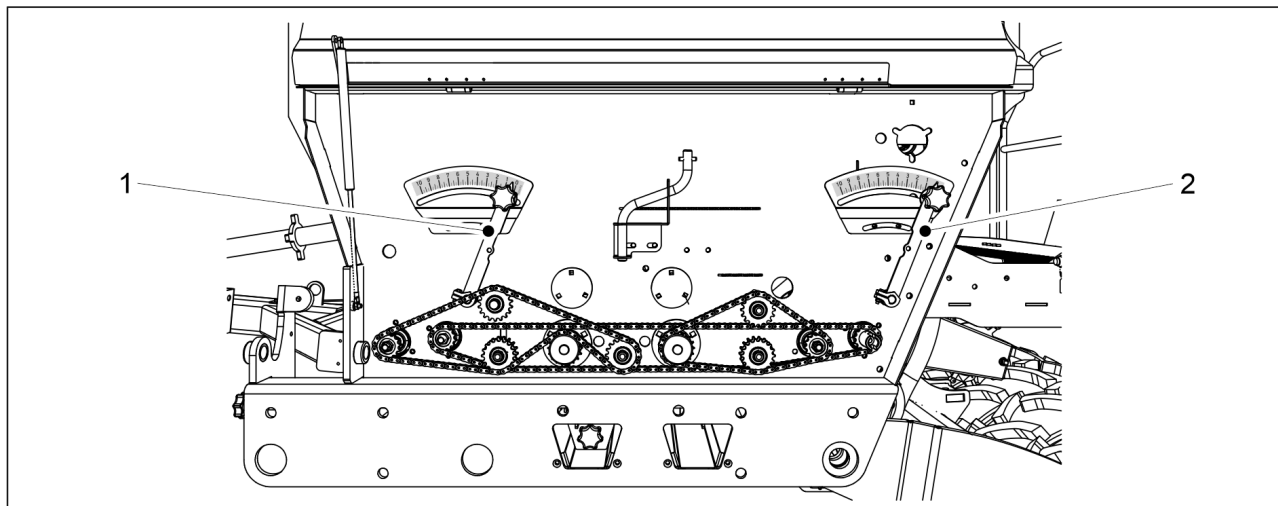

Figure. 6.6.6 - 132. Adjusting the feeding quantity, fertiliser and seed

1. Adjust the fertiliser and seed feed rates by means of control levers on the left-hand transmission of the machine.
 - Control lever (1) is for fertiliser and control lever (2) is for seed. The adjustment scale at the tip of the adjustment lever has values between 0 and 10. When the tip of the adjustment lever is at 0, the feed rate is 0%. When the tip of the adjustment lever is at 10, the feed rate is 100%.

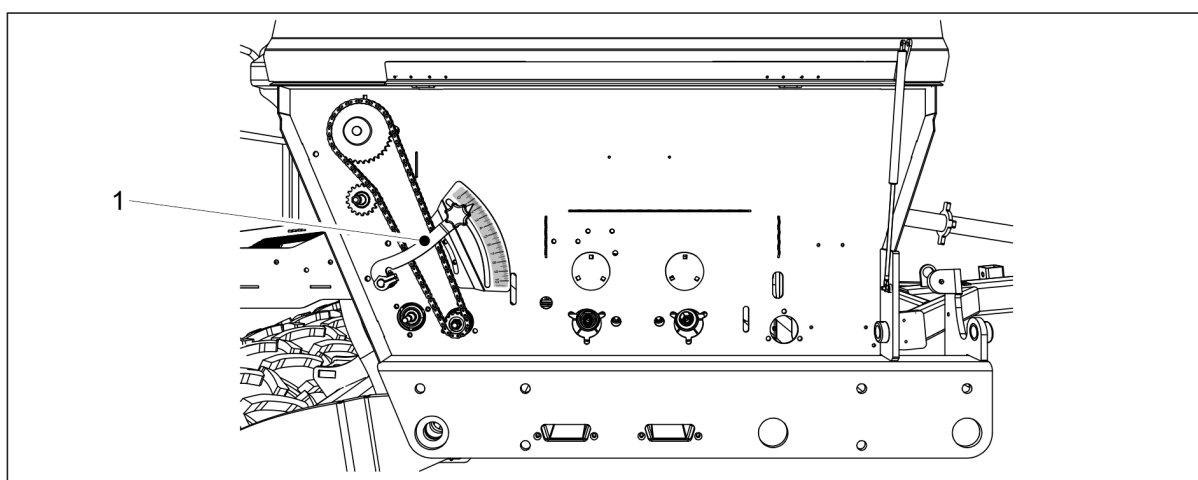

Figure. 6.6.6 - 133. Adjusting the feed rate, small seed

2. Adjust the small seed feed rate by means of a control lever (1) on the right-hand transmission of the machine.

- The adjustment scale at the tip of the adjustment lever has values between 0 and 10. When the tip of the adjustment lever is at 0, the feed rate is 0%. When the tip of the adjustment lever is at 10, the feed rate is 100%.

6.6.7 Adjusting the fertiliser hopper feeder units

6.6.7.1 Adjusting the bottom flap position



CAUTION

When the machine is in use, the control lever for the bottom flaps must be in one of the limiter slots. If the control lever is placed past the limiter, the machine's calibration test flap cannot turn freely.

Figure. 6.6.7.1 - 134. Control lever for the bottom flaps of the feeder units, fertiliser hopper

1. Move the control lever (1) on the limiter (2) on the slot scale according to the material to be seeded.
 - FORTE 300 EVO: 1 set of control levers in the middle of the machine.
FORTE 400 EVO: 2 control levers (1 in the middle of each half of the hopper).

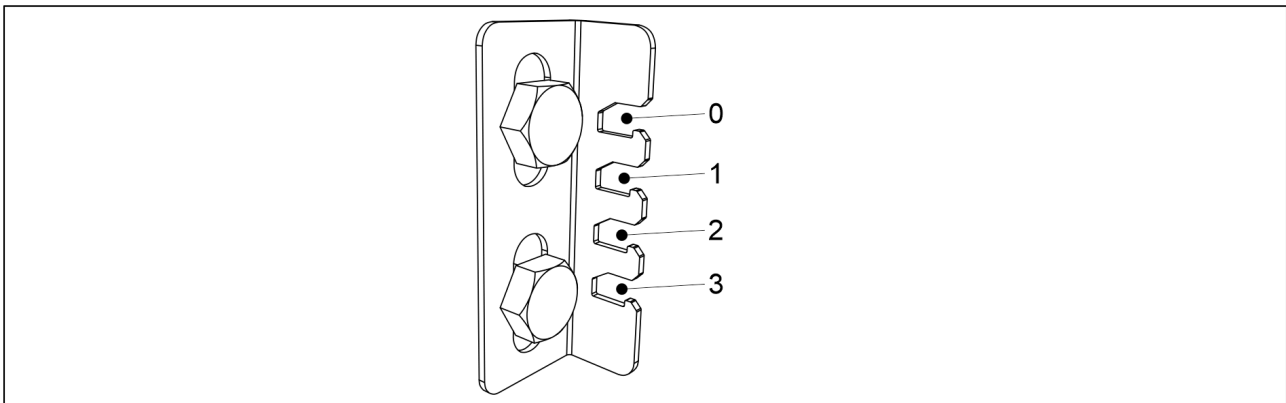

Figure. 6.6.7.1 - 135. Control lever positions/material to be seeded

- When seeding small seeds, set the control lever to position 0.
When seeding grain and fertiliser, set the control lever to position 1.
When seeding large seeds such as peas or beans, set the control lever to position 3.
When seeding organic fertiliser, set the control lever to position 3.

6.6.7.2 Adjusting the shut-off plate position

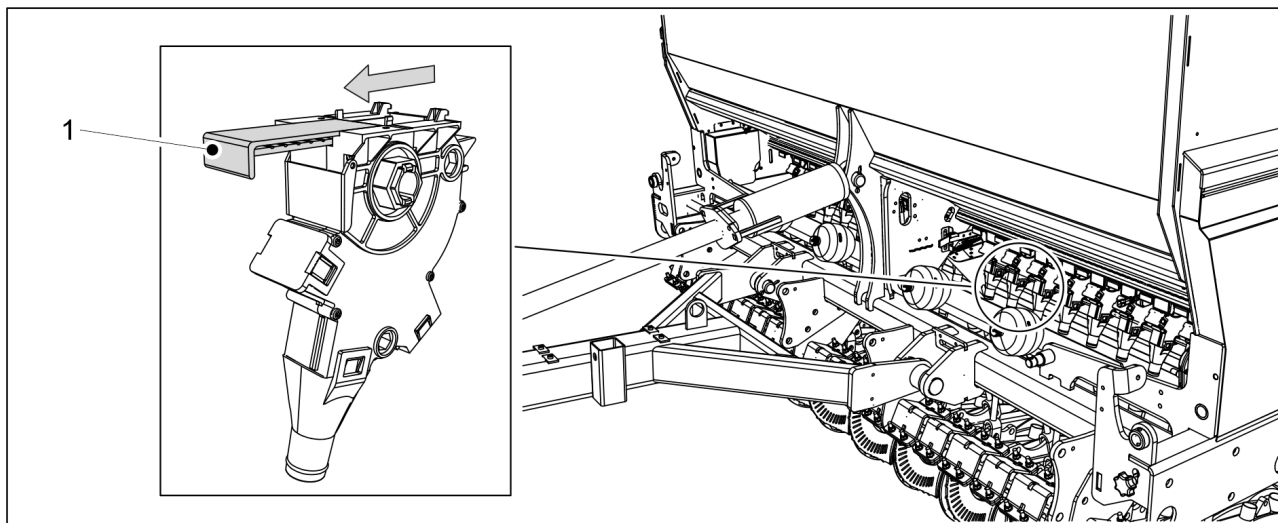

Figure. 6.6.7.2 - 136. Shut-off plate on the fertiliser feeder unit

1. For all fertiliser feeders to be used, set the shut-off plate (1) fully open.
 - A fertiliser seeding table can be found in chapter [6.5 Seeding quantities](#).

6.6.8 Adjusting the seed hopper feeder units

6.6.8.1 Adjusting the bottom flap position



CAUTION

When the machine is in use, the control lever for the bottom flaps must be in one of the limiter slots. If the control lever is placed past the limiter, the machine's calibration test flap cannot turn freely.

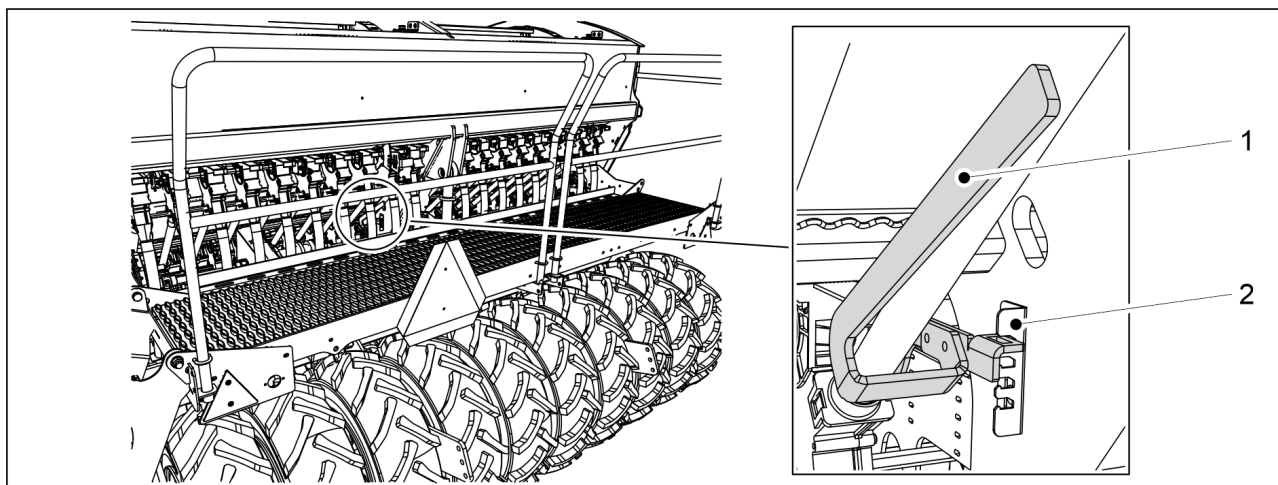

Figure. 6.6.8.1 - 137. Control lever for the bottom flaps of the feeder units, seed hopper

1. Move the control lever (1) on the limiter (2) on the slot scale according to the material to be seeded.
 - FORTE 300 EVO: 1 set of control levers in the middle of the machine.
 - FORTE 400 EVO: 2 control levers (1 in the middle of each half of the hopper).

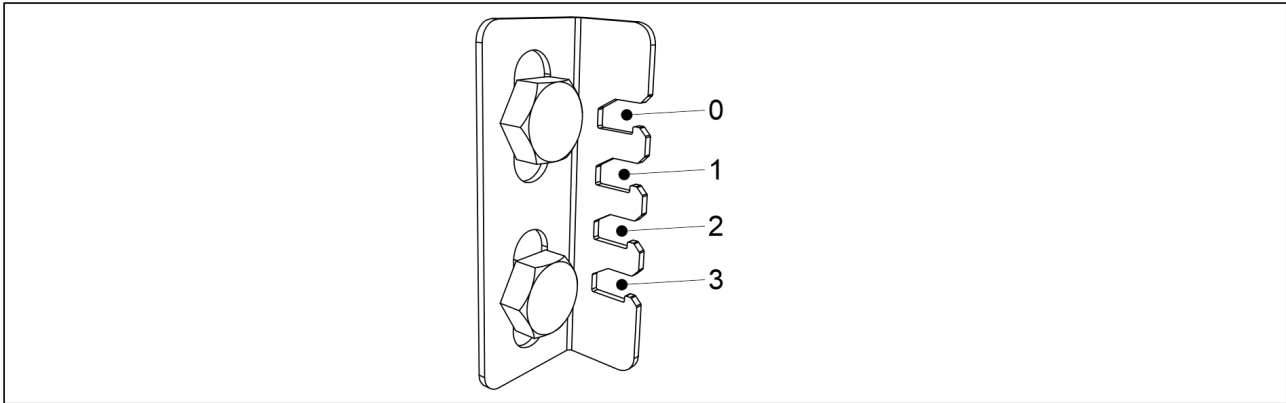

Figure. 6.6.8.1 - 138. Control lever positions/material to be seeded

- When seeding small seeds, set the control lever to position 0.
When seeding grain and fertiliser, set the control lever to position 1.
When seeding large seeds, such as peas or beans, set the control lever to position 3.
When seeding organic fertiliser, set the control lever to position 3.

6.6.8.2 Adjusting the shut-off plate position

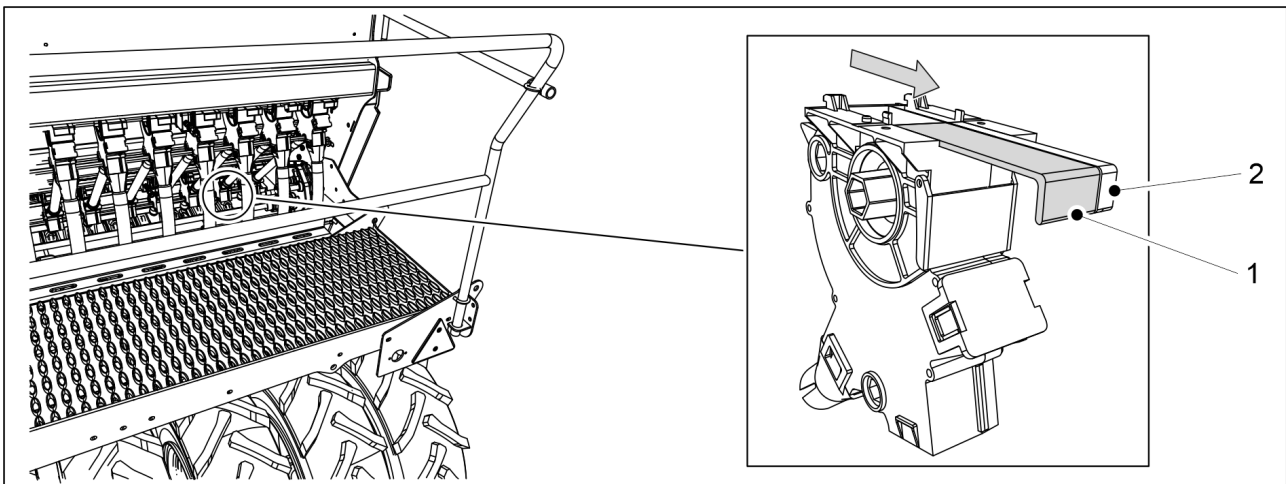

Figure. 6.6.8.2 - 139. Shut-off plate on the seed feeder unit

1. Depending on the material to be seeded, set either the wide shut-off plate (1) or the narrow shut-off plate (2) fully open on all seed feeders to be used.
 - A seed seeding table can be found in chapter [6.5 Seeding quantities](#).

6.6.9 Adjusting the small seed hopper feeder units

6.6.9.1 Adjusting the bottom flap position

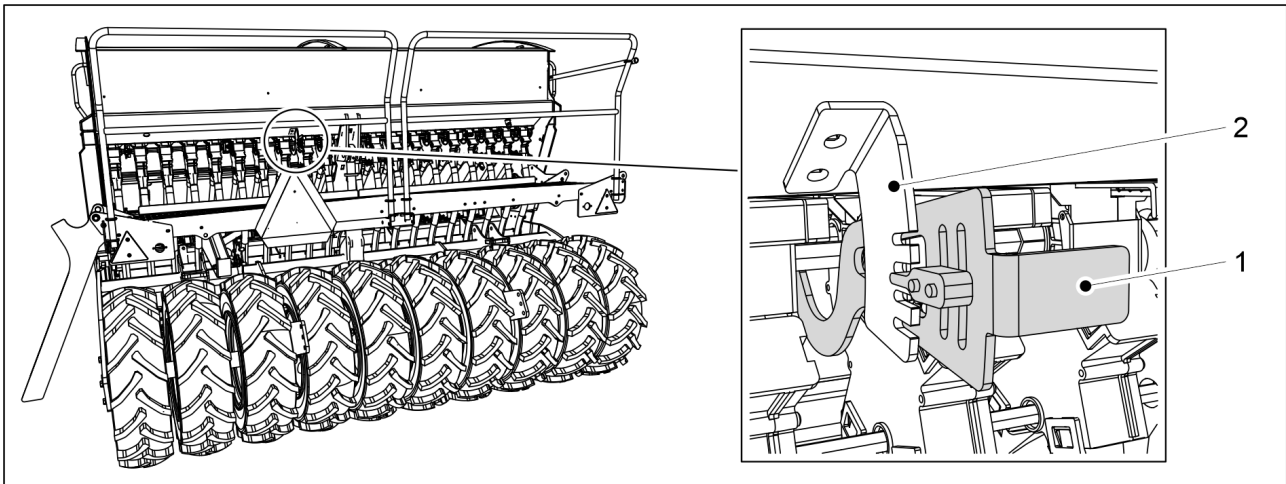

Figure. 6.6.9.1 - 140. Control lever for the bottom flaps of the feeder units, small seed hopper

1. Move the control lever (1) on the limiter (2) on the slot scale according to the material to be seeded.
 - FORTE 300 EVO: 1 set of control levers in the middle of the machine.
 - FORTE 400 EVO: 2 control levers (1 in the middle of each half of the hopper).

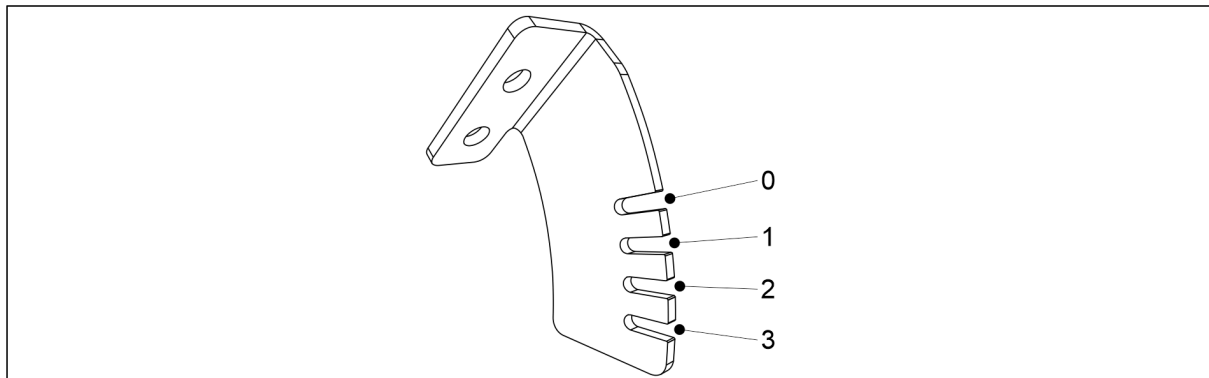

Figure. 6.6.9.1 - 141. Control lever positions/material to be seeded

- When seeding small seeds, set the control lever to position 0.
- When seeding fertiliser, set the control lever to position 1.

6.6.9.2 Adjusting the shut-off plate position

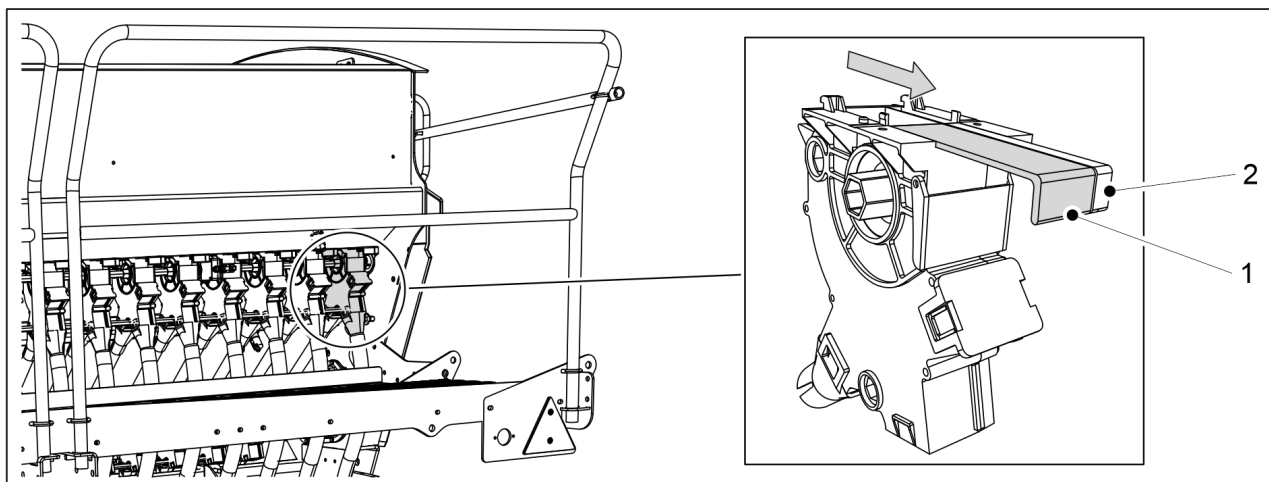

Figure. 6.6.9.2 - 142. Shut-off plates on the small seed feeder unit

1. Depending on the material to be seeded, set either the wide shut-off plate (1) or the narrow shut-off plate (2) fully open on all seed feeders to be used.
 - A small seed table can be found in chapter [6.5 Seeding quantities](#).

6.6.10 Selection of small seed seeding method

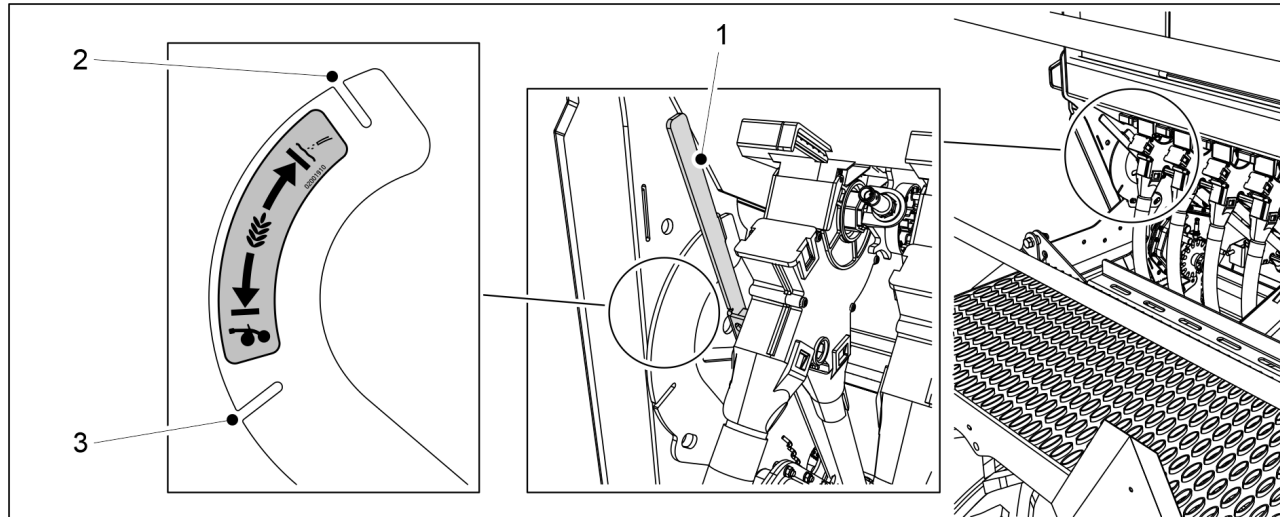

Figure. 6.6.10 - 143. Selection of small seed seeding method

1. Use lever (1) to select the seeding method for small seed.
 - When the control lever is in slot (2), the seeding is directed to the surface through a separate pipe.
 - When the control lever is in slot (3), the seed is directed into the coulter with the seed.

6.7 Filling the hoppers



DANGER

Falling hazard when performing work on the platform. Be careful when performing work on the platform. Accessing the steps of the platform is allowed only when the machine is lowered.

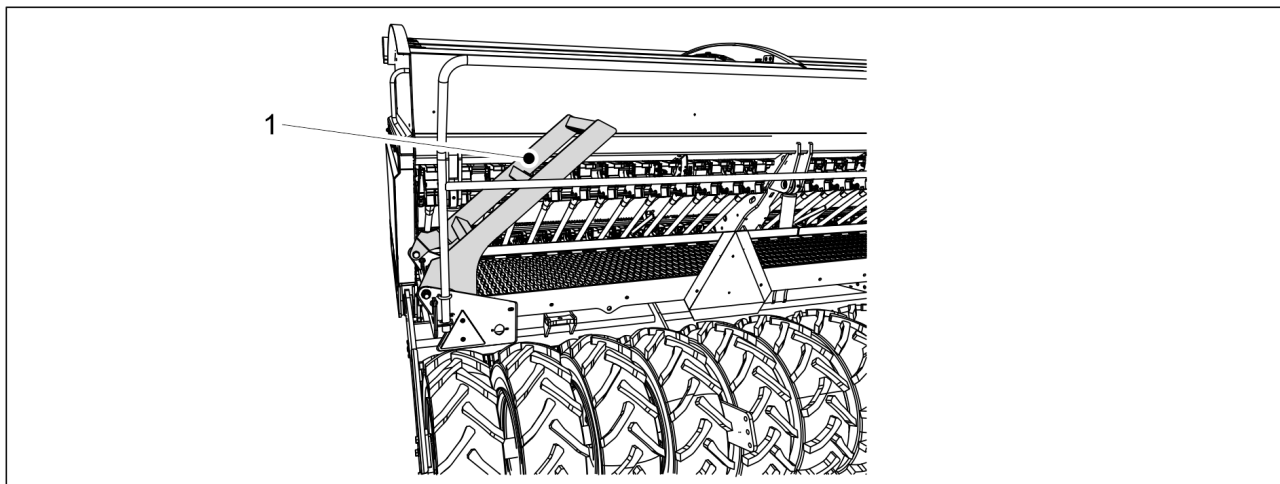

Figure. 6.7 - 144. Working platform stairs

1. Lower the machine to its working position in accordance with the instructions in section [6.2 Rendering the machine to the working position](#) and fold the working platform stairs (1) down.

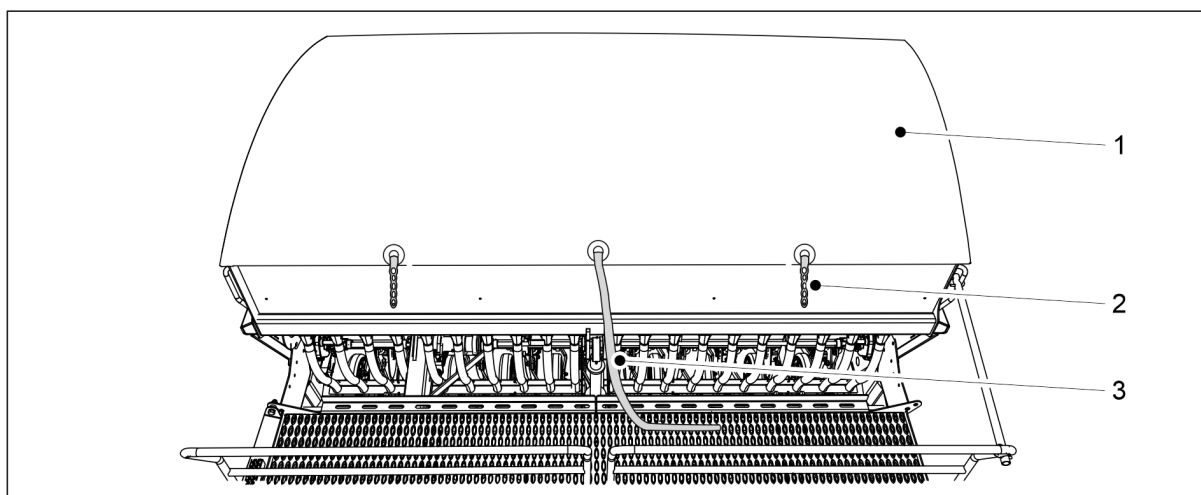

Figure. 6.7 - 145. Hopper tarp

2. Detach the two loops (2) of the hopper tarp (1).
3. Pull the cord (3).
 - There is a spring inside the tarp that will roll it up. Never let the go of the tarp, but hold the end until the tarp is open.

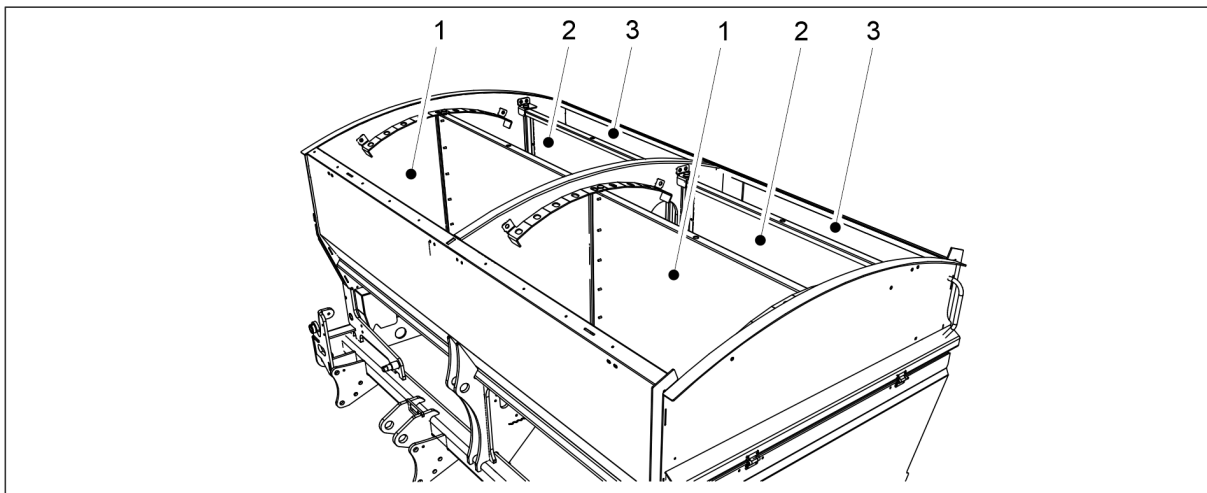

Figure. 6.7 - 146. Filling the hoppers

4. Fill the hoppers.

- Hopper (1) is for fertiliser. Hopper (2) is for seed. Hopper (3) is for small seed.

DANGER



Never go under a lifted load.

DANGER



Make sure that nobody is on top of the seed drill or inside the hoppers when the hoppers are being filled.

DANGER



Avoid breathing seed dressing dust and fertiliser dust. The seed dressing causes a serious health risk.

DANGER



Read the material safety data sheet of the dressing agent and fertiliser and follow their warnings.

- It is recommended that the hoppers be filled from the side of the hoppers. We recommend that you open the bulk bags using a knife with a long handle or a pruning hook.

5. Close the tarp (1) and attach the two tarp loops (2).

6. Fold the working platform stairs up.

- When raised, the stairs will be at an approximately 40 degree angle to the working platform.

6.8 Product calibration

The seeding tables that contain the basic values for adjusting the seeding quantity are located under the transmission cover in the seed drill. The seeding tables are presented in section [6.5 Seeding quantities](#). However, there are great differences between various seeds, which is why the actual seeding quantity must always be checked with a calibration test. Seed treatment, such as seed dressing, has considerable impact on fluidity.

The calibration test should be performed whenever changes are made to the feeding quantities. In particular, fertiliser quantities may vary a lot due to the moisture and fluidity of the fertiliser.

When driving on the road with hoppers full of fertiliser and seeds, the vibration may cause arching in the hoppers. In the autumn or after rain, the fertiliser may absorb humidity in the feeders, changing fertiliser fluidity. For this reason, it is good to monitor that fertiliser or seed flow evenly from all feeders when seeding begins. Performing a calibration test is in order and visually checking that the feed quantity is even in all feeders.

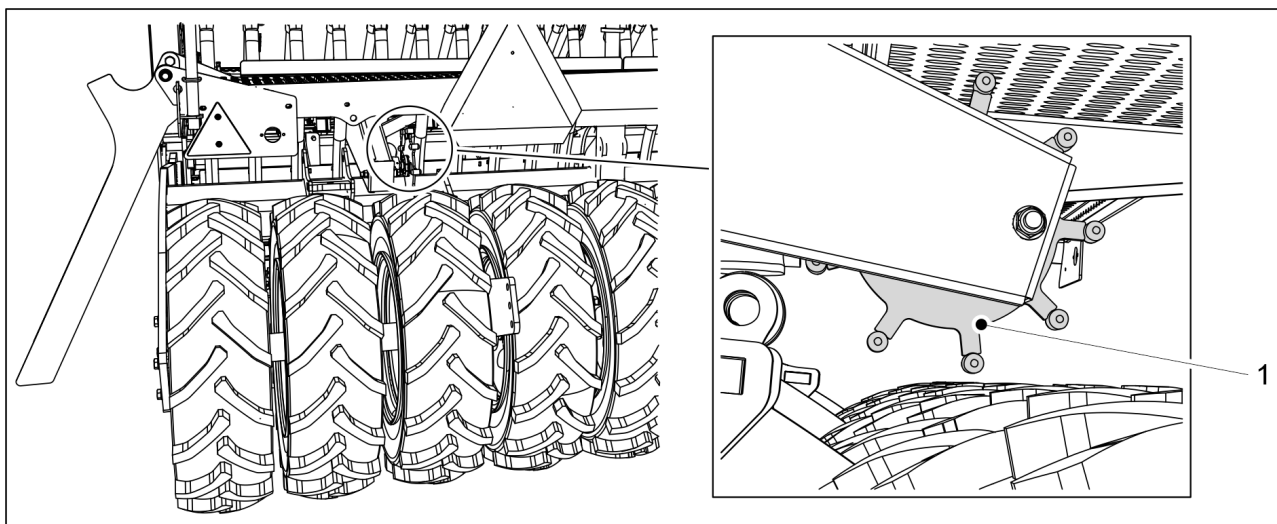

Figure. 6.8 - 147. Pulley

- When running a calibration test on the machine, the machine must be raised from its working position so that the pulley (1) comes off of the tyres.

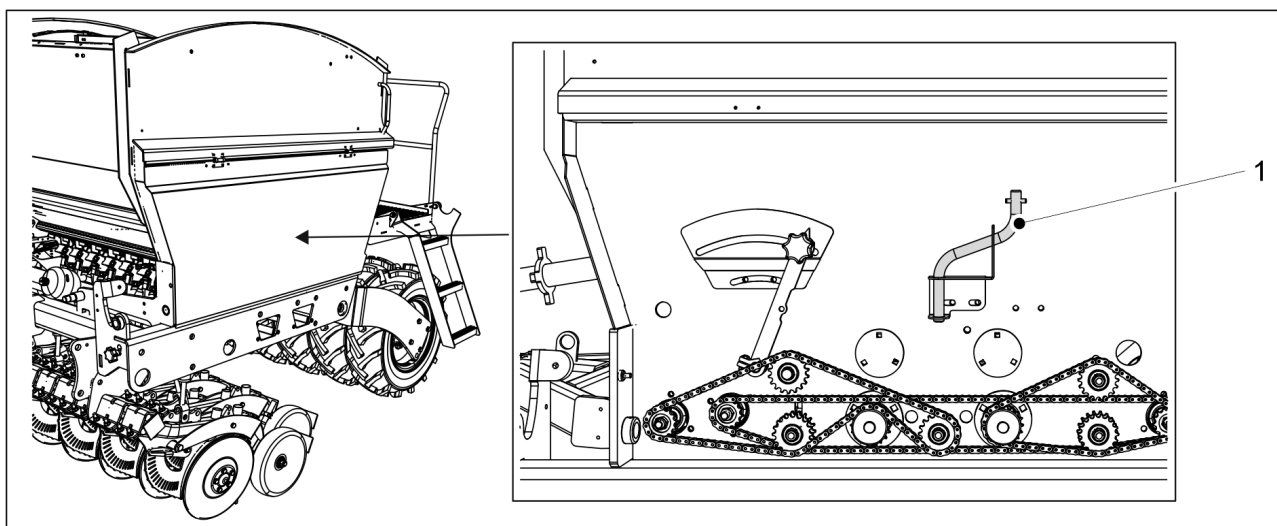

Figure. 6.8 - 148. Location of the calibration test crank

- Use the calibration test crank (1) supplied with the machine when performing a calibration test. The crank is located behind the transmission cover on the left side of the machine.

6.8.1 Fertiliser calibration test



DANGER

Shut off the tractor, remove the key from the ignition and engage the parking brake before running a calibration test. If the machine is equipped with middle markers, close the middle marker shut-off valves in accordance with section [3.4 Using the middle marker ball valves](#).

1. Lift the transmission cover on both sides of the machine.

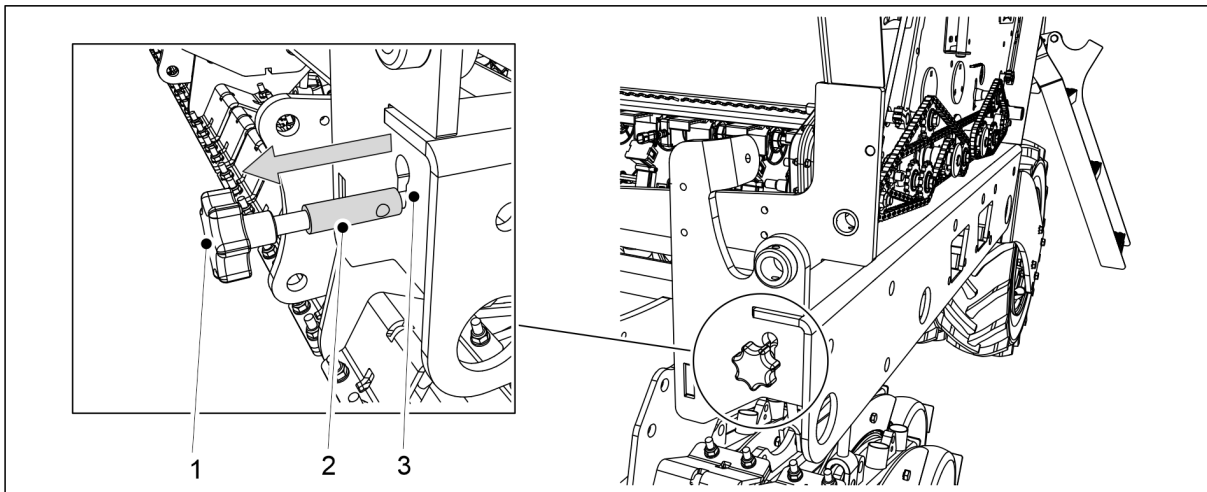

Figure. 6.8.1 - 149. Pulling out the calibration test adjuster rod

2. Pull the rod (1) outwards until the gauge band of the rod (2) is completely visible outside the frame's slot (3).
 - Pulling out the adjuster rod moves the feeders' flaps to the calibration position.
3. Empty the calibration trays.
 - Soil may have accumulated in the calibration trays during operation.

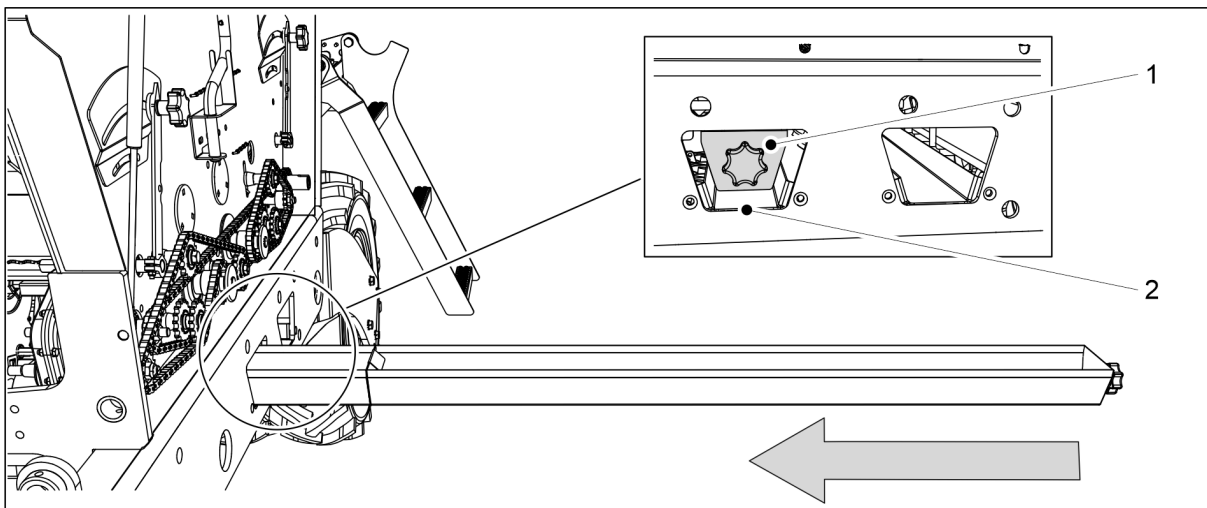

Figure. 6.8.1 - 150. Setting the calibration trays

4. Push the calibration trays (1) in a horizontal position under the fertiliser feeder line.
 - The fertiliser feeder line is located in the machine frame at the foremost opening (2).

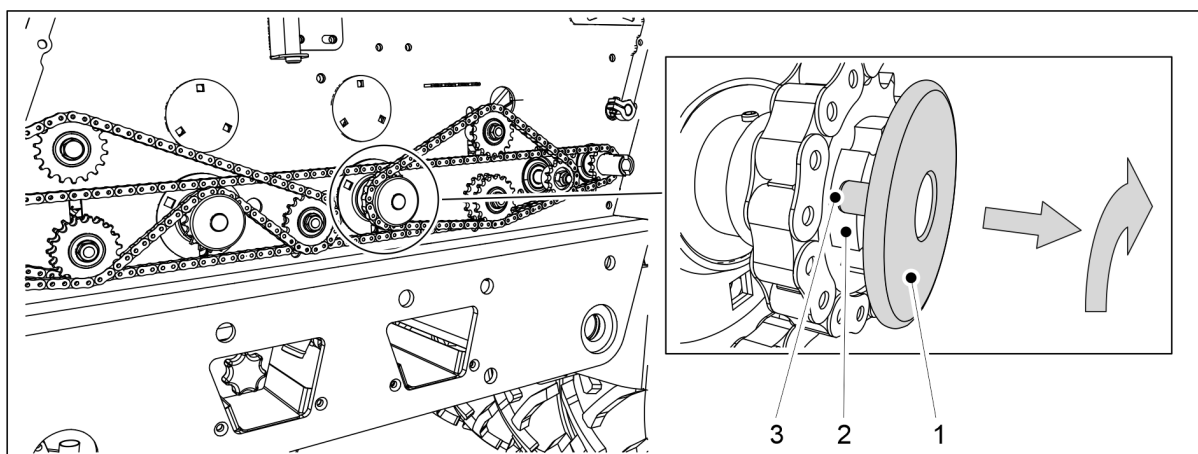

Figure. 6.8.1 - 151. Seed feeder deactivation

5. Pull the seed feeder locking plate (1) outwards and position the locking studs of the disc in line with the grooves (3) of the guide bushing (2).
 - The seed feeder is now deactivated.

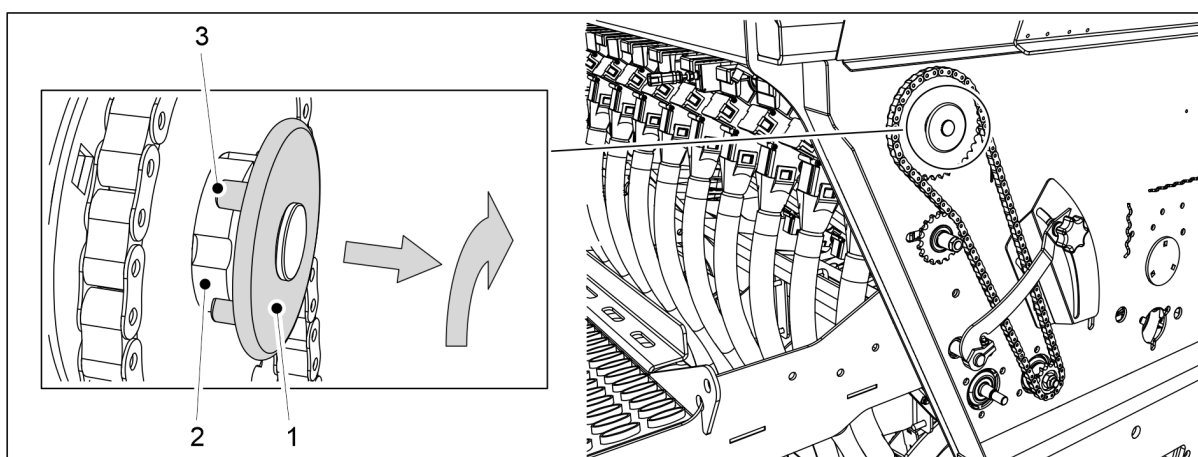

Figure. 6.8.1 - 152. Small seed feeder deactivation

6. If the machine has a small seed hopper: Pull the small seed feeder locking plate (1) outwards and position the locking studs of the disc in line with the grooves (3) of the guide bushing (2).
 - The small seed feeder is now deactivated.

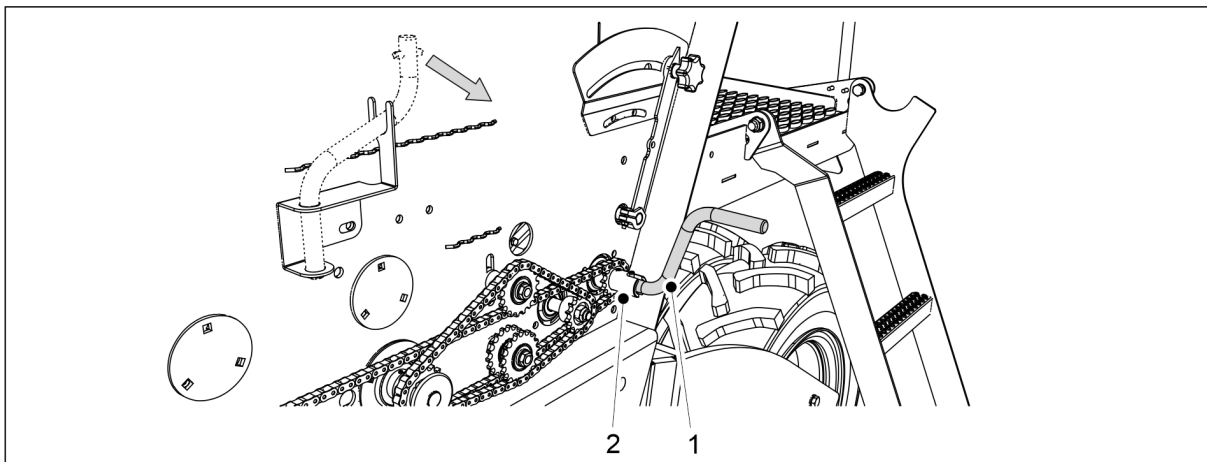

Figure. 6.8.1 - 153. Fastening the calibration test crank

7. Fasten the calibration test crank (1) to the calibration test axle(2).
8. Turn the crank until an even flow of fertiliser comes out of all feeders.
9. Empty the calibration trays.
10. Rotate the axle counterclockwise by 1 round per second using the calibration test crank.
 - An area of 100 m² is obtained by turning the crank 34 times on the FORTE 300 EVO and 25.5 times on the FORTE 400 EVO.
11. Pull out the calibration trays and weigh the quantities they now contain.
 - Use the calibration test bags and scale delivered with the machine for weighing.
The calibration test quantity obtained corresponds to the area of 100 m² , so the quantities for a hectare will be hundredfold.
If the weighing result does not match the desired quantity, adjust the fertiliser feed rate in accordance with section 6.6.6 Adjusting the feeding quantity with the gearbox control lever.
12. Repeat the calibration test. Make sure that the result is sufficiently close to the target quantity.
13. Place the calibration trays in the machine. Ensure that the trays are in the correct order and that they are connected to each other correctly.

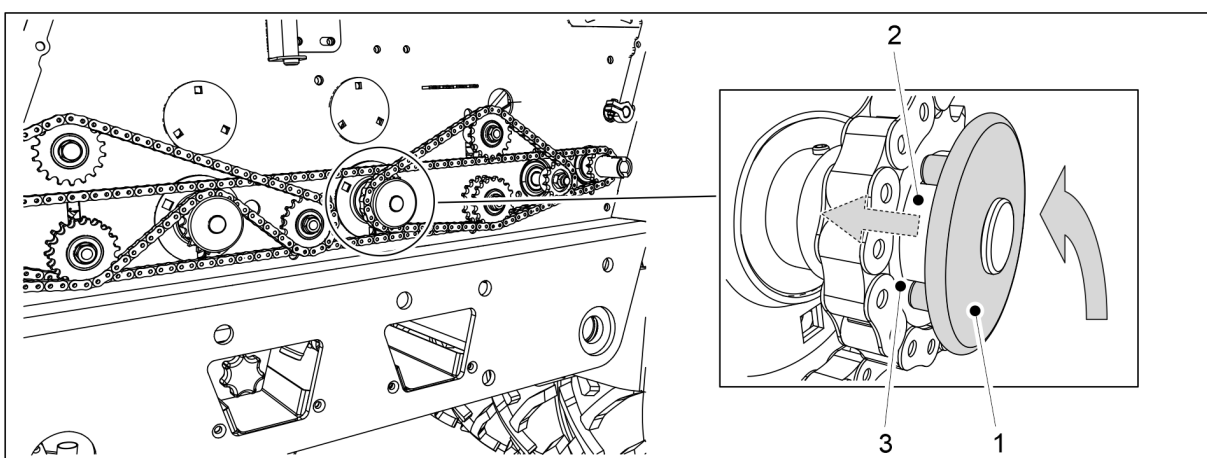

Figure. 6.8.1 - 154. Returning the seed feeder to the operating position

14. Rotate the seed feeders locking disc (1) so that the locking studs of the disc are aligned with the grooves (3) of the guide bushing (2).

- The spring of the shaft pulls the locking disc into place.

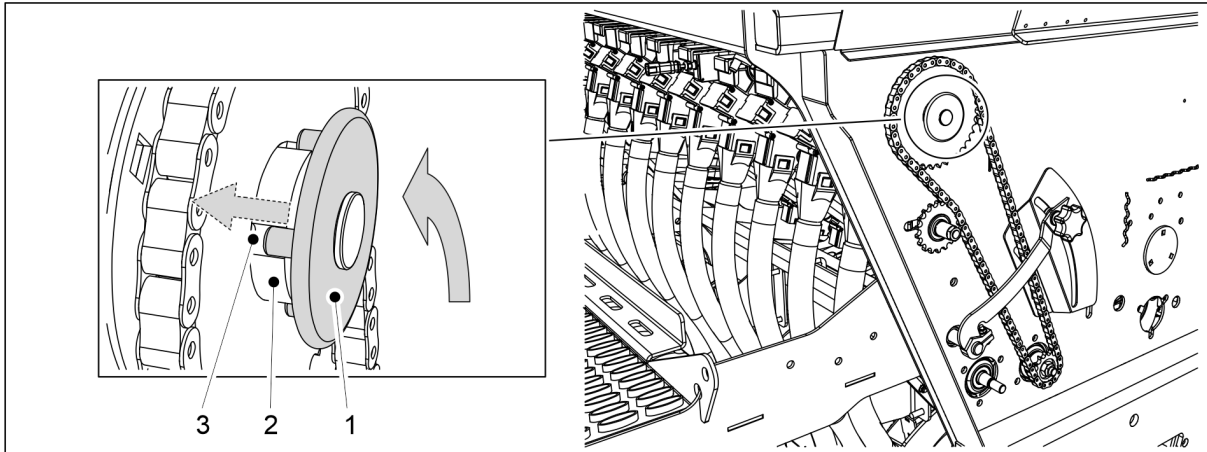

Figure. 6.8.1 - 155. Returning the small seed feeder to the operating position

15. If the machine has a small seed hopper: Rotate the small seed feeders locking disc (1) so that the locking studs of the disc are aligned with the grooves (3) of the guide bushing (2).

- The spring of the shaft pulls the locking disc into place.

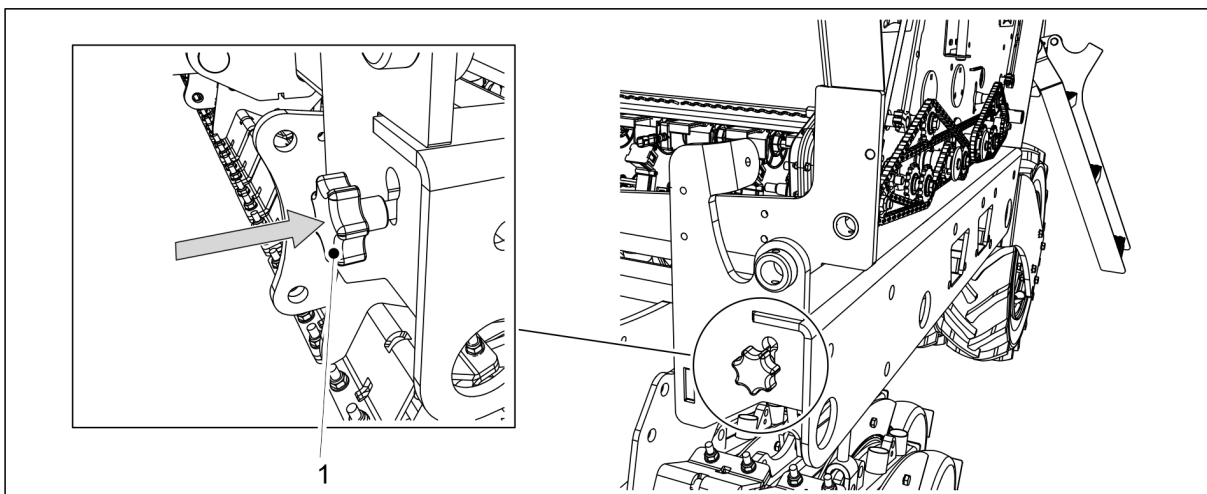

Figure. 6.8.1 - 156. Inserting the calibration test adjuster rod

16. Insert the calibration test adjuster rod (1) into the machine frame.
 - Inserting the adjuster rod moves the feeders' flaps to the seeding position.
17. Fold the transmission cover on both sides of the machine.

6.8.2 Seed calibration test



DANGER

Shut off the tractor, remove the key from the ignition and engage the parking brake before running a calibration test. If the machine is equipped with middle markers, close the middle marker shut-off valves in accordance with section [3.4 Using the middle marker ball valves](#).

1. Lift the transmission cover on both sides of the machine.

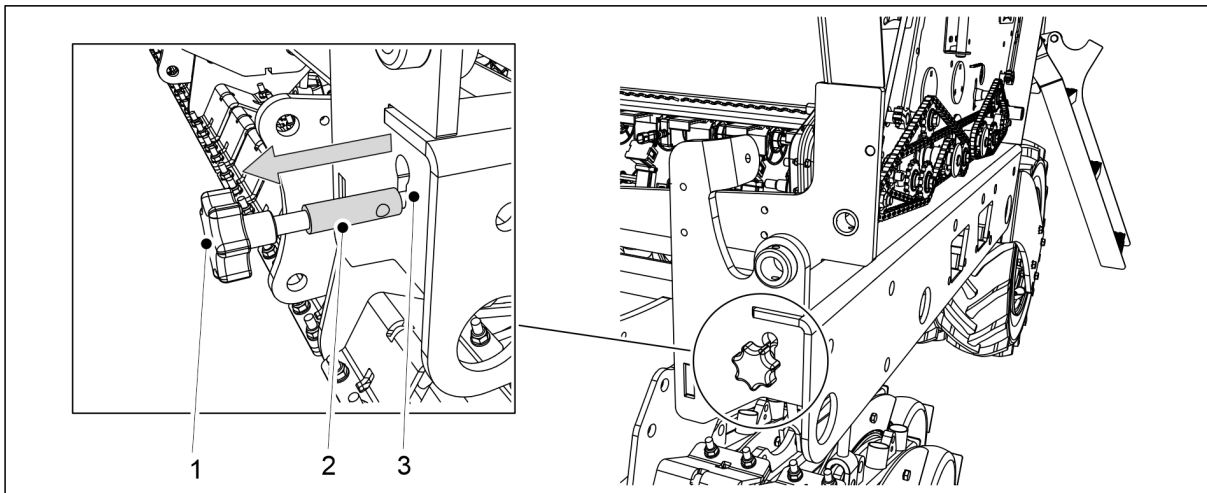

Figure. 6.8.2 - 157. Pulling out the calibration test adjuster rod

2. Pull the rod (1) outwards until the gauge band of the rod (2) is completely visible outside the frame's slot (3).
 - Pulling out the adjuster rod moves the feeders' flaps to the calibration position.
3. Empty the calibration trays.
 - Soil may have accumulated in the calibration trays during operation.

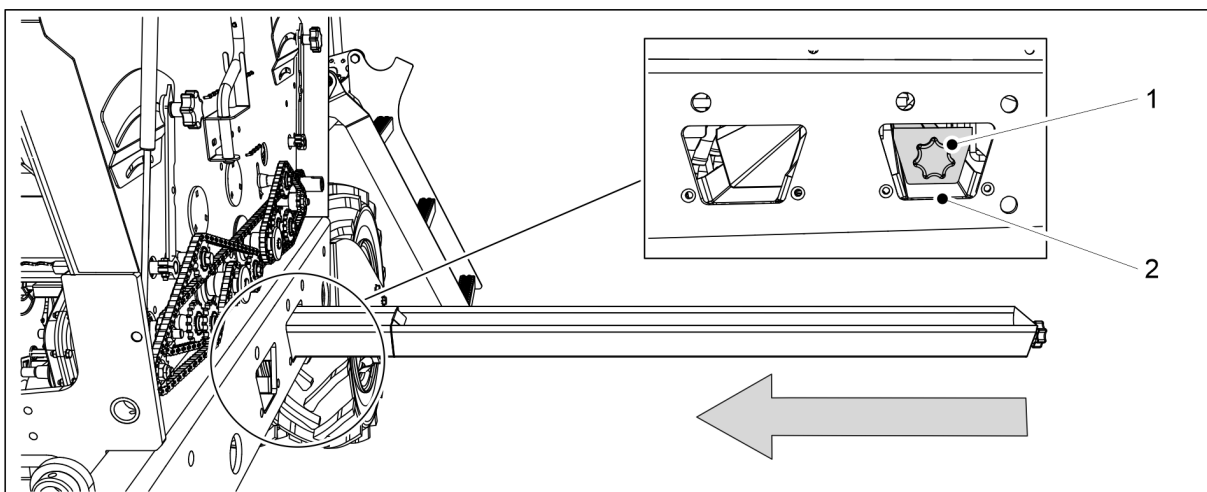

Figure. 6.8.2 - 158. Setting the calibration trays

4. Push the calibration trays (1) in a horizontal position under the seed feeder line.
 - The seed feeder line is located in the machine frame at the rearmost opening (2).

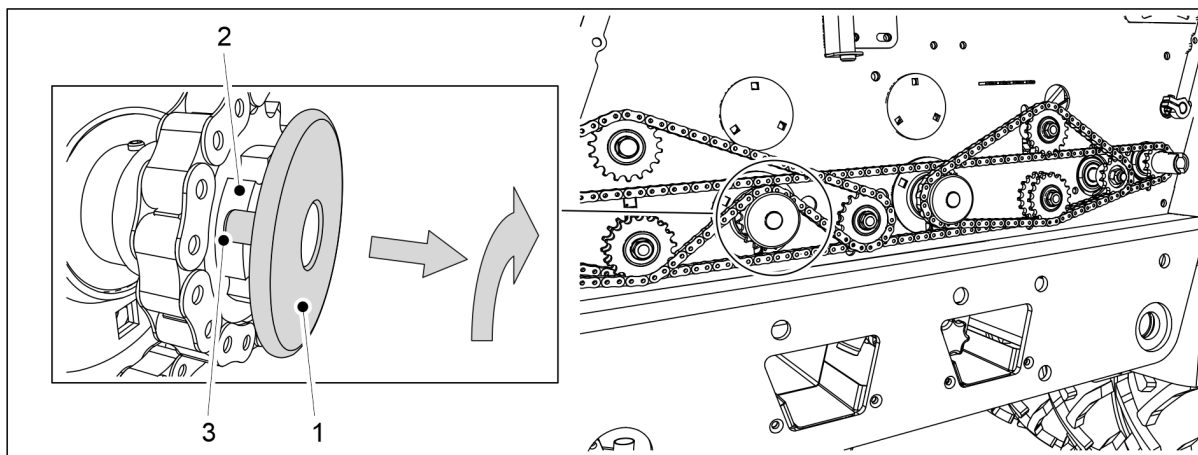

Figure. 6.8.2 - 159. Deactivation of the fertiliser feeder

5. Pull the fertiliser feeder locking plate (1) outwards and position the locking studs of the disc in line with the grooves (3) of the guide bushing (2).
 - The fertiliser feeder is now deactivated.

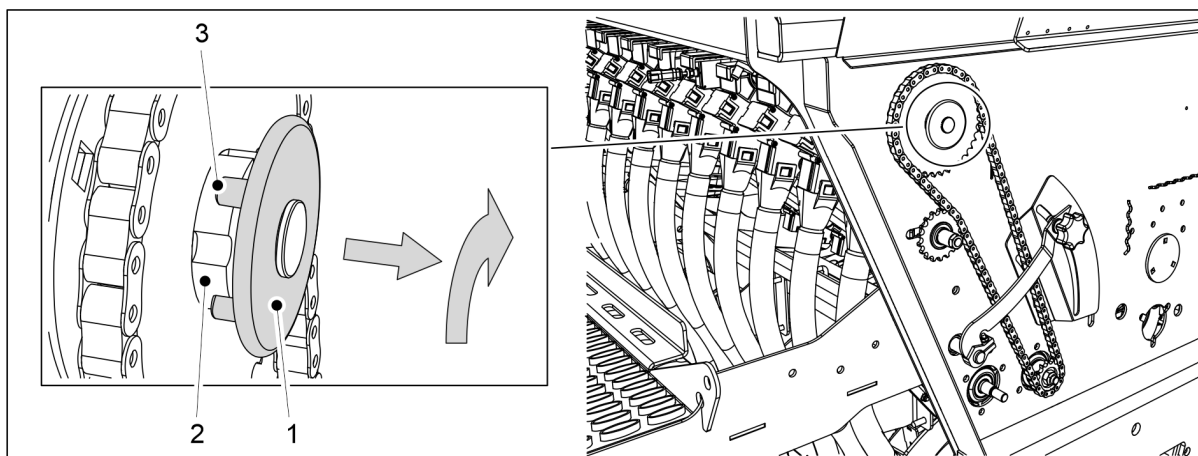

Figure. 6.8.2 - 160. Small seed feeder deactivation

6. If the machine has a small seed hopper: Pull the small seed feeder locking plate (1) outwards and position the locking studs of the disc in line with the grooves (3) of the guide bushing (2).
 - The small seed feeder is now deactivated.

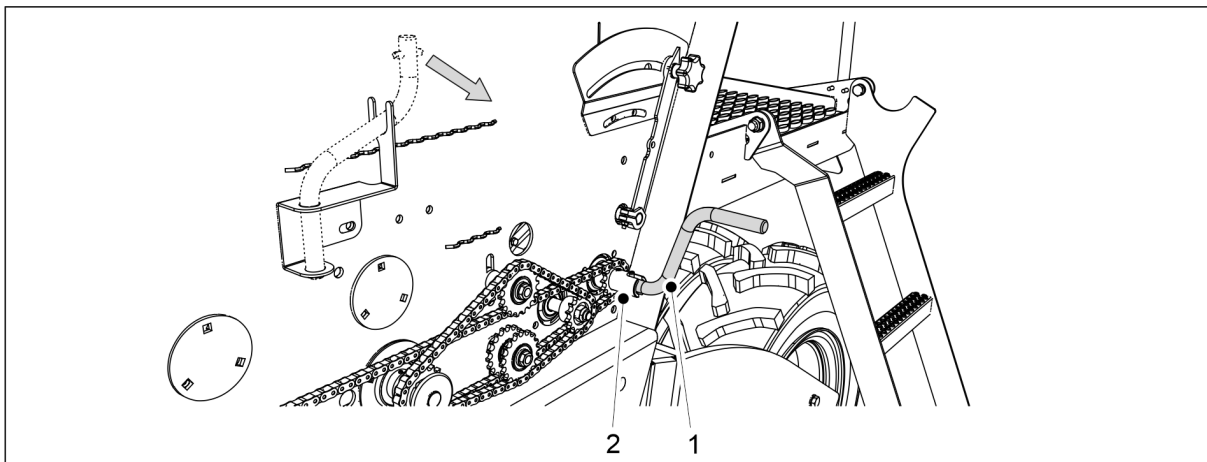

Figure. 6.8.2 - 161. Fastening the calibration test crank

7. Fasten the calibration test crank (1) to the calibration test axle(2).
8. Turn the crank until an even flow of fertiliser comes out of all feeders.
9. Empty the calibration trays.
10. Rotate the axle counterclockwise by 1 round per second using the calibration test crank.
 - An area of 100 m² is obtained by turning the crank 34 times on the FORTE 300 EVO and 25.5 times on the FORTE 400 EVO.
11. Pull out the calibration trays and weigh the quantities they now contain.
 - Use the calibration test bags and scale delivered with the machine for weighing.
The calibration test quantity obtained corresponds to the area of 100 m² , so the quantities for a hectare will be hundredfold.
If the weighing result does not match the desired quantity, adjust the seed feed rate in accordance with section 6.6.6 Adjusting the feeding quantity with the gearbox control lever.
12. Repeat the calibration test. Make sure that the result is sufficiently close to the target quantity.
13. Place the calibration trays in the machine. Ensure that the trays are in the correct order and that they are connected to each other correctly.

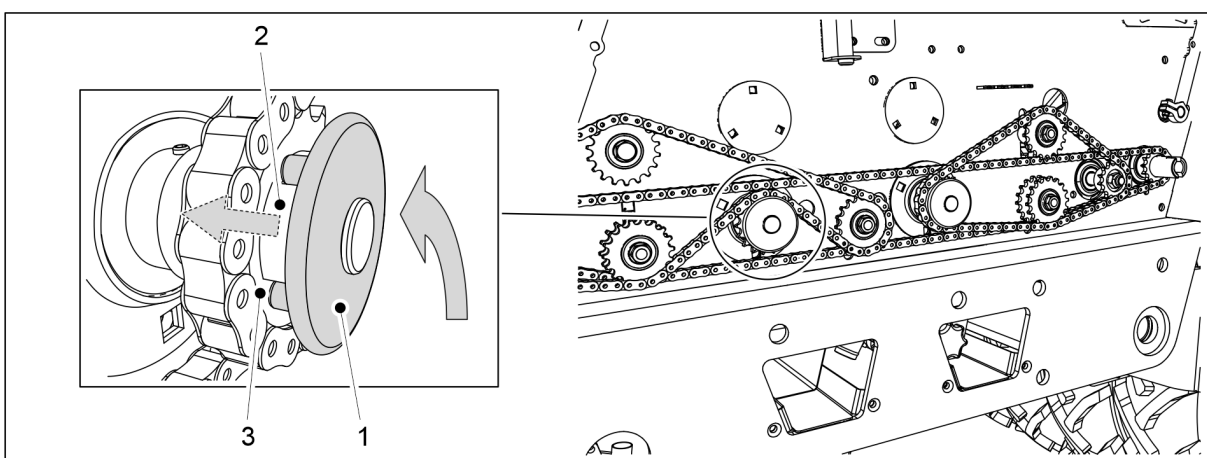

Figure. 6.8.2 - 162. Returning the fertiliser feeder to the operating position

14. Rotate the fertiliser feeder's locking disc (1) so that the locking studs of the disc are aligned with the grooves (3) of the guide bushing (2).

- The spring of the shaft pulls the locking disc into place.

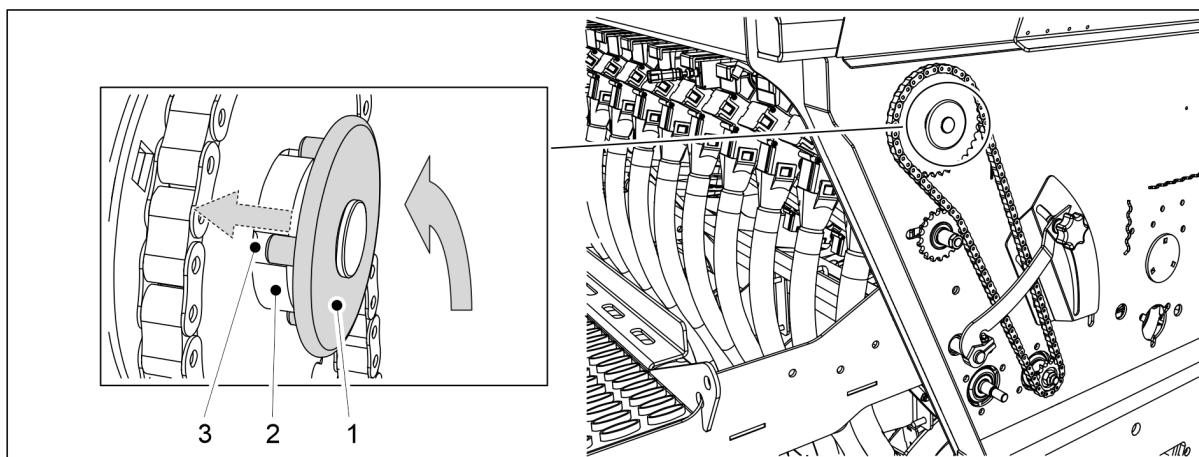

Figure. 6.8.2 - 163. Returning the small seed feeder to the operating position

15. If the machine has a small seed hopper: Rotate the small seed feeders locking disc (1) so that the locking studs of the disc are aligned with the grooves (3) of the guide bushing (2).

- The spring of the shaft pulls the locking disc into place.

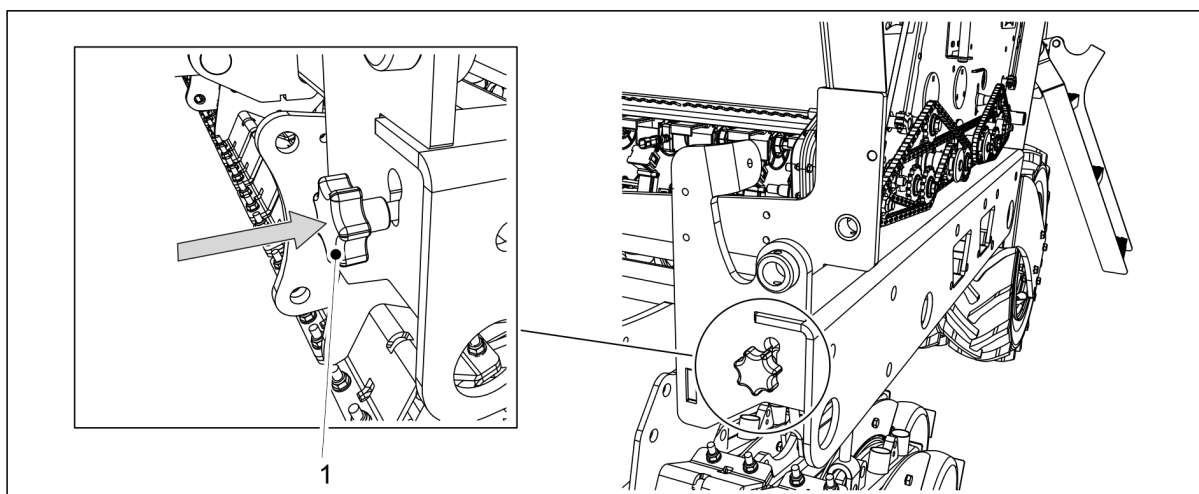

Figure. 6.8.2 - 164. Inserting the calibration test adjuster rod

16. Insert the calibration test adjuster rod (1) into the machine frame.
 - Inserting the adjuster rod moves the feeders' flaps to the seeding position.
17. Fold the transmission cover on both sides of the machine.

6.8.3 Small seed calibration test



DANGER

Shut off the tractor, remove the key from the ignition and engage the parking brake before running a calibration test. If the machine is equipped with middle markers, close the middle marker shut-off valves in accordance with section [3.4 Using the middle marker ball valves](#).

1. Lift the transmission cover on both sides of the machine.

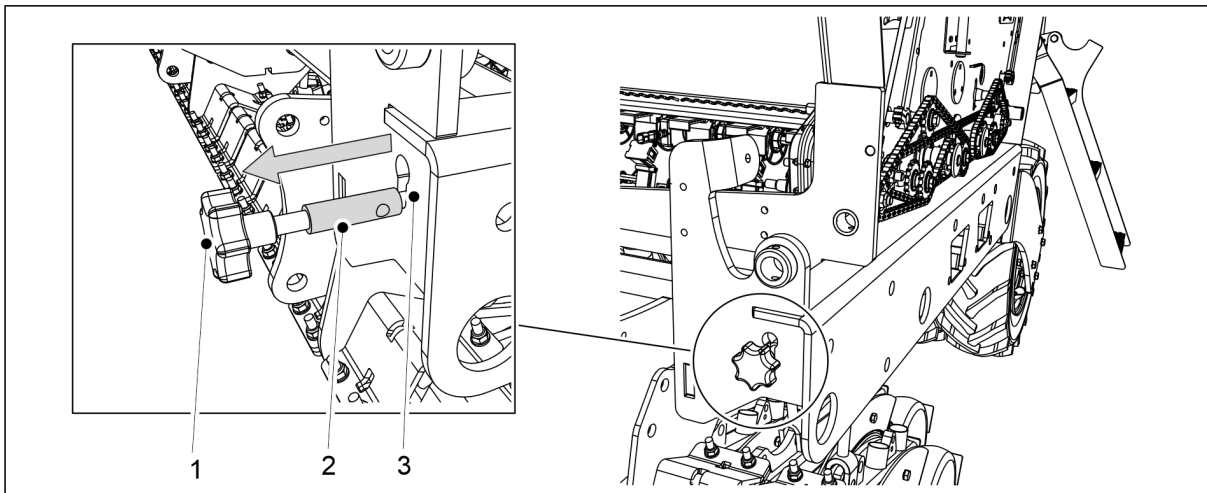

Figure. 6.8.3 - 165. Pulling out the calibration test adjuster rod

2. Pull the rod (1) outwards until the gauge band of the rod (2) is completely visible outside the frame's slot (3).
 - Pulling out the adjuster rod moves the feeders' flaps to the calibration position.
3. Empty the calibration trays.
 - Soil may have accumulated in the calibration trays during operation.

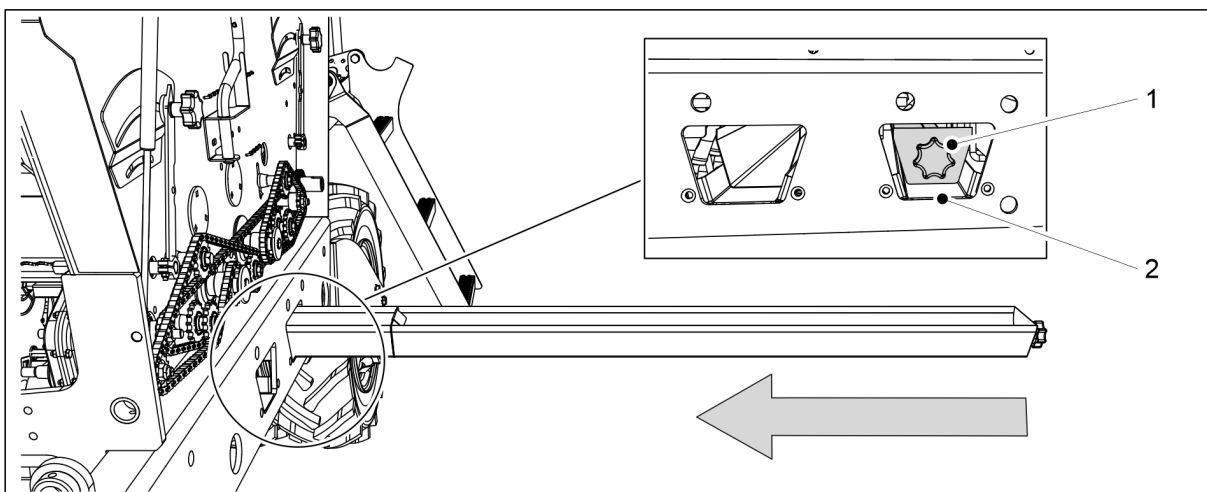

Figure. 6.8.3 - 166. Setting the calibration trays

4. Push the calibration trays (1) in a horizontal position under the seed feeder line.
 - The seed feeder line is located in the machine frame at the rearmost opening (2).

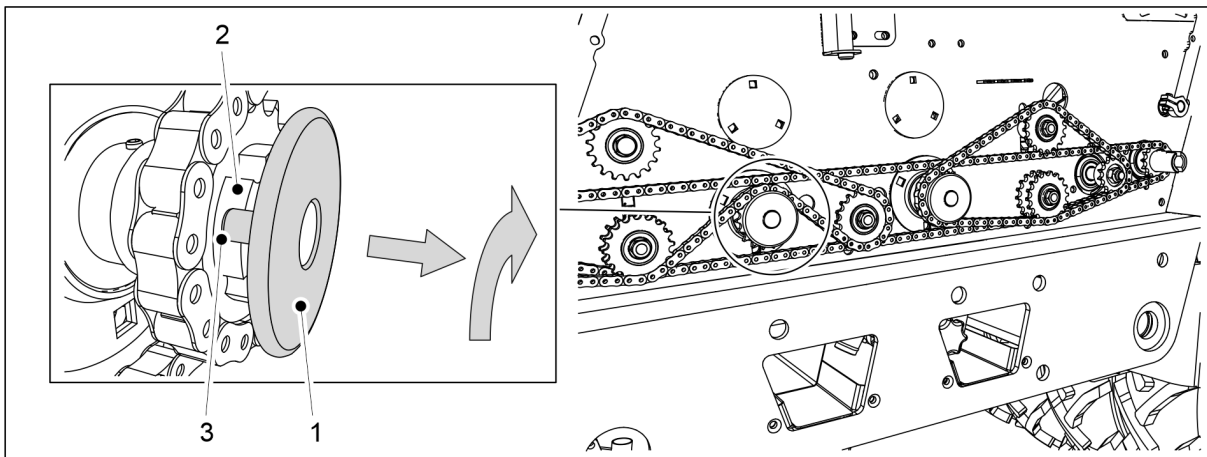

Figure. 6.8.3 - 167. Deactivation of the fertiliser feeder

5. Pull the fertiliser feeder locking plate (1) outwards and position the locking studs of the disc in line with the grooves (3) of the guide bushing (2).

- The fertiliser feeder is now deactivated.

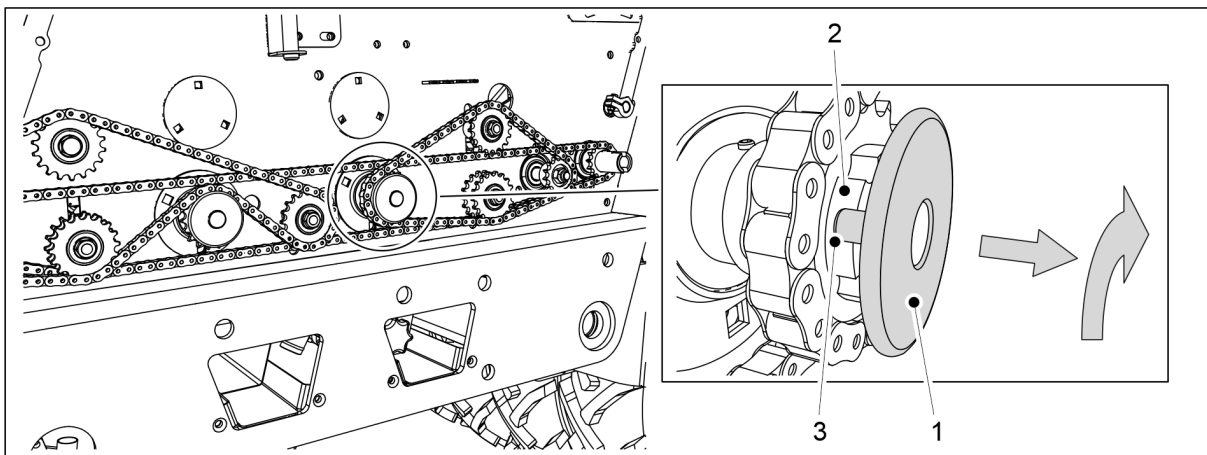

Figure. 6.8.3 - 168. Seed feeder deactivation

6. Pull the seed feeder locking plate (1) outwards and position the locking studs of the disc in line with the grooves (3) of the guide bushing (2).

- The seed feeder is now deactivated.

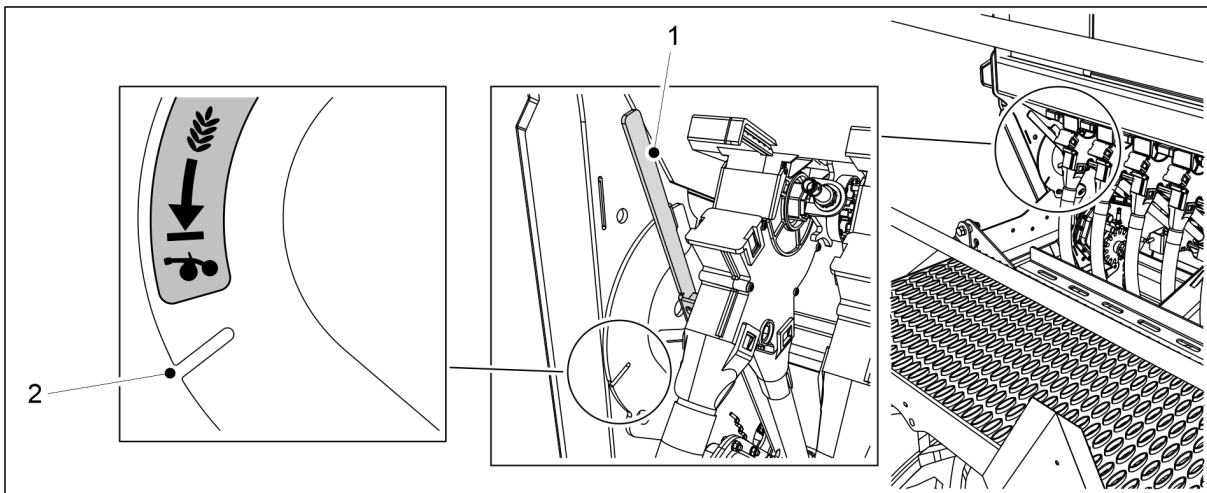

Figure. 6.8.3 - 169. Selection of small seed seeding method

7. Turn the small seed seeding mode selector lever (1) to slot (2) to guide the small seeds into the coulter.

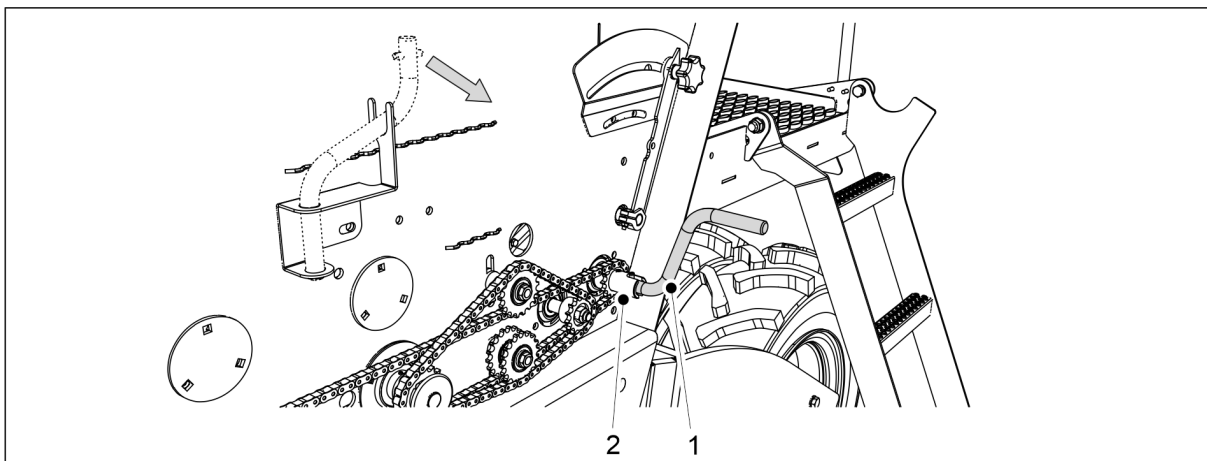

Figure. 6.8.3 - 170. Fastening the calibration test crank

8. Fasten the calibration test crank (1) to the calibration test axle(2).
9. Turn the crank until an even flow of fertiliser comes out of all feeders.
10. Empty the calibration trays.
11. Rotate the axle counterclockwise by 1 round per second using the calibration test crank.
 - An area of 100 m² is obtained by turning the crank 34 times on the FORTE 300 EVO and 25.5 times on the FORTE 400 EVO.
12. Pull out the calibration trays and weigh the quantities they now contain.
 - Use the calibration test bags and scale delivered with the machine for weighing.
The calibration test quantity obtained corresponds to the area of 100 m² , so the quantities for a hectare will be hundredfold.
If the weighing result does not match the desired quantity, adjust the small seeds feed rate in accordance with section 6.6.6 Adjusting the feeding quantity with the gearbox control lever.
13. Repeat the calibration test. Make sure that the result is sufficiently close to the target quantity.

- Place the calibration trays in the machine. Ensure that the trays are in the correct order and that they are connected to each other correctly.

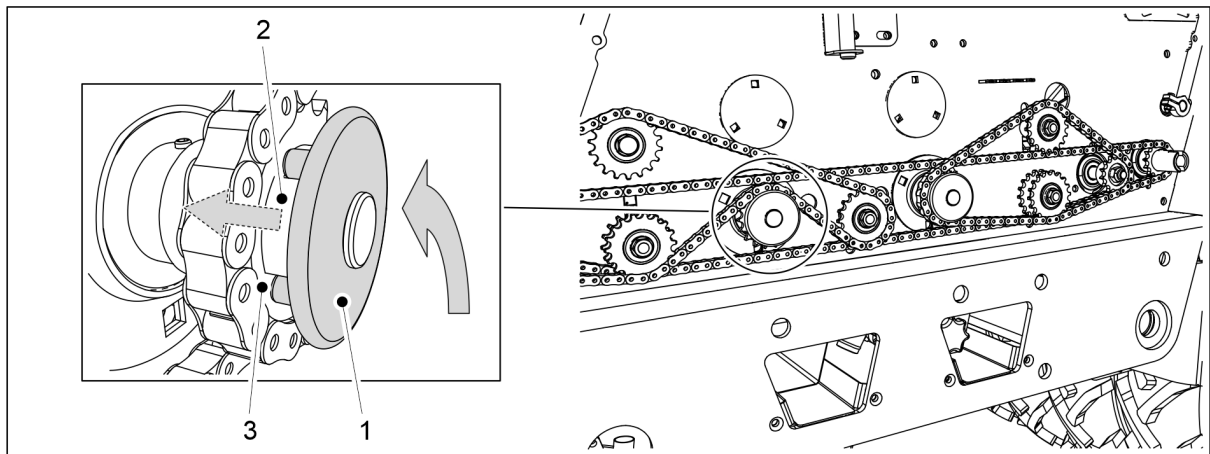

Figure. 6.8.3 - 171. Returning the fertiliser feeder to the operating position

- Rotate the fertiliser feeder's locking disc (1) so that the locking studs of the disc are aligned with the grooves (3) of the guide bushing (2).
 - The locking disc return spring pulls the disc into place.

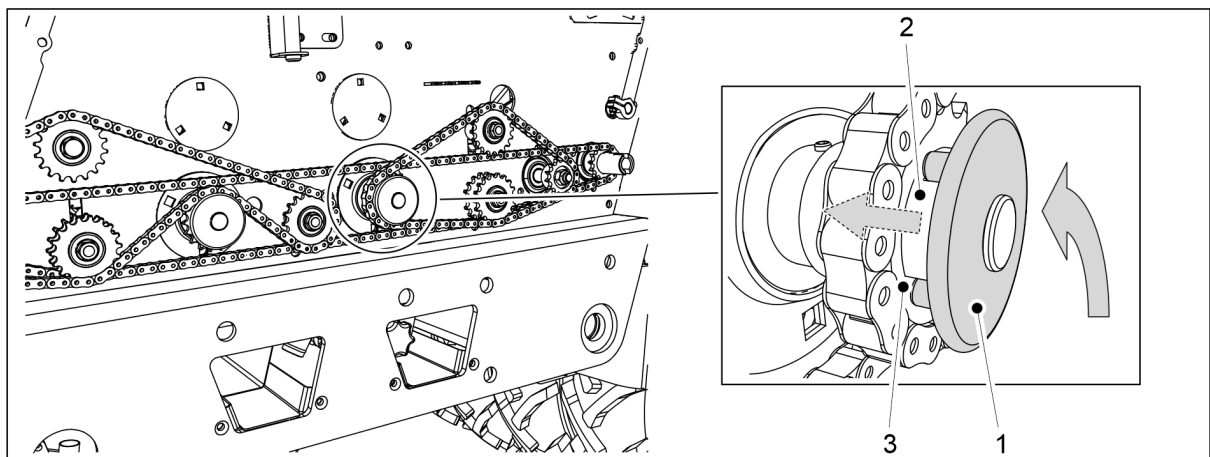

Figure. 6.8.3 - 172. Returning the seed feeder to the operating position

- Rotate the seed feeders locking disc (1) so that the locking studs of the disc are aligned with the grooves (3) of the guide bushing (2).
 - The locking disc return spring pulls the disc into place.

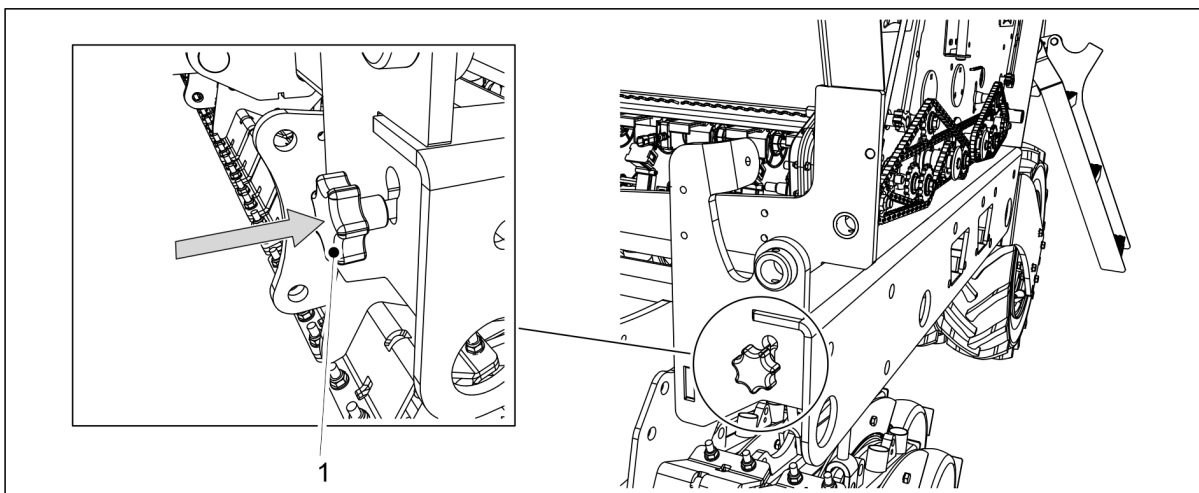

Figure. 6.8.3 - 173. Inserting the calibration test adjuster rod

17. Insert the calibration test adjuster rod (1) into the machine frame.
 - Inserting the adjuster rod moves the feeders' flaps to the seeding position.
18. Fold the transmission cover on both sides of the machine.

6.8.4 Calibration test with adjusting of the fertiliser target rate



DANGER

Engage the tractor handbrake before running the calibration test. If the machine is equipped with middle markers, close the middle marker shut-off valves in accordance with section [3.4 Using the middle marker ball valves](#).

Preparations

1. Lift the transmission cover on both sides of the machine.

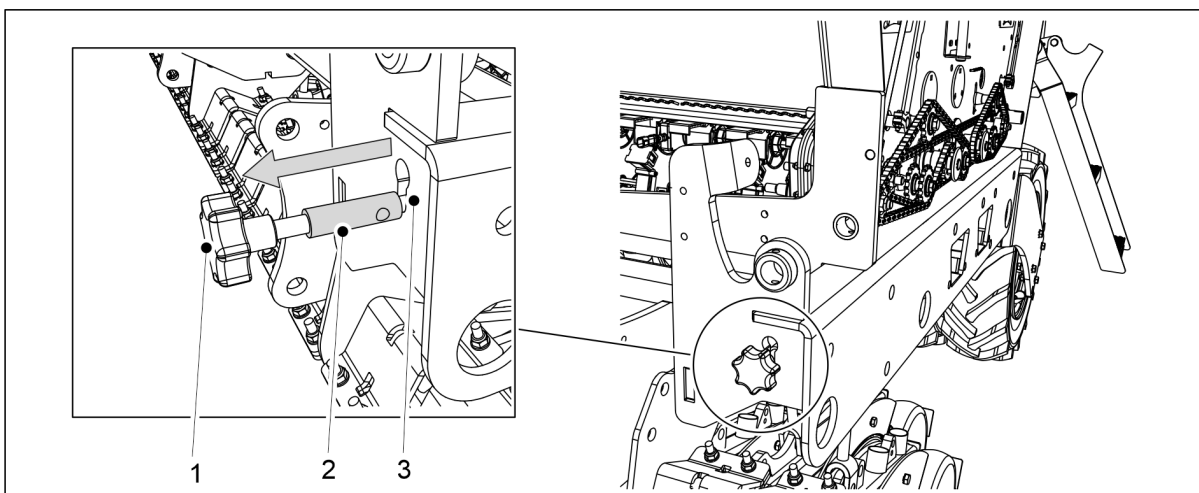

Figure. 6.8.4 - 174. Pulling out the calibration test adjuster rod

2. Pull the rod (1) outwards until the gauge band of the rod (2) is completely visible outside the frame's slot (3).
 - Pulling out the adjuster rod moves the feeders' flaps to the calibration position.
3. Empty the calibration trays.

- Soil may have accumulated in the calibration trays during operation.

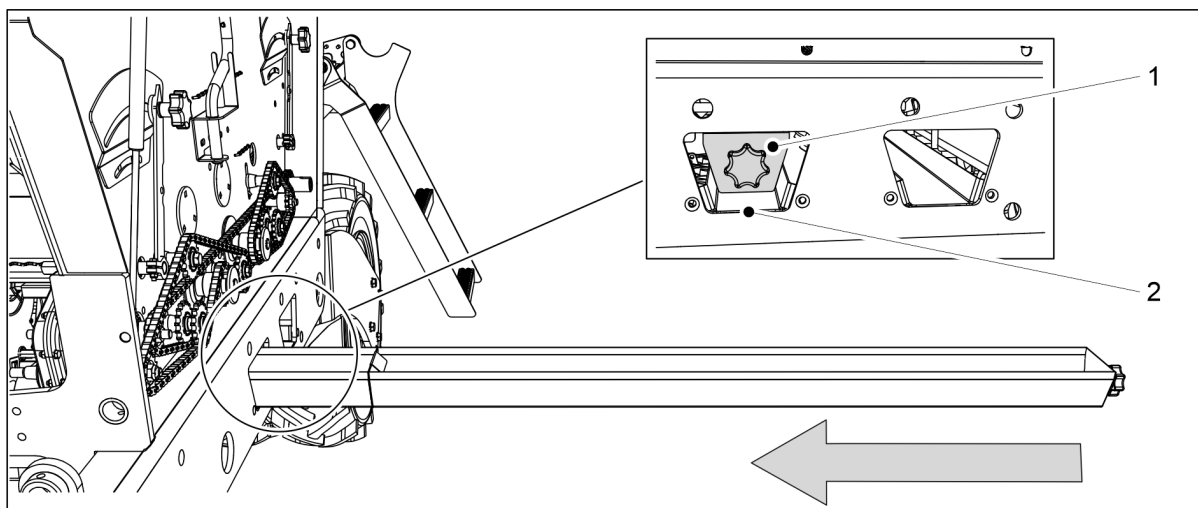

Figure. 6.8.4 - 175. Setting the calibration trays

4. Push the calibration trays (1) in a horizontal position under the fertiliser feeder line.
 - The fertiliser feeder line is located in the machine frame at the foremost opening (2).

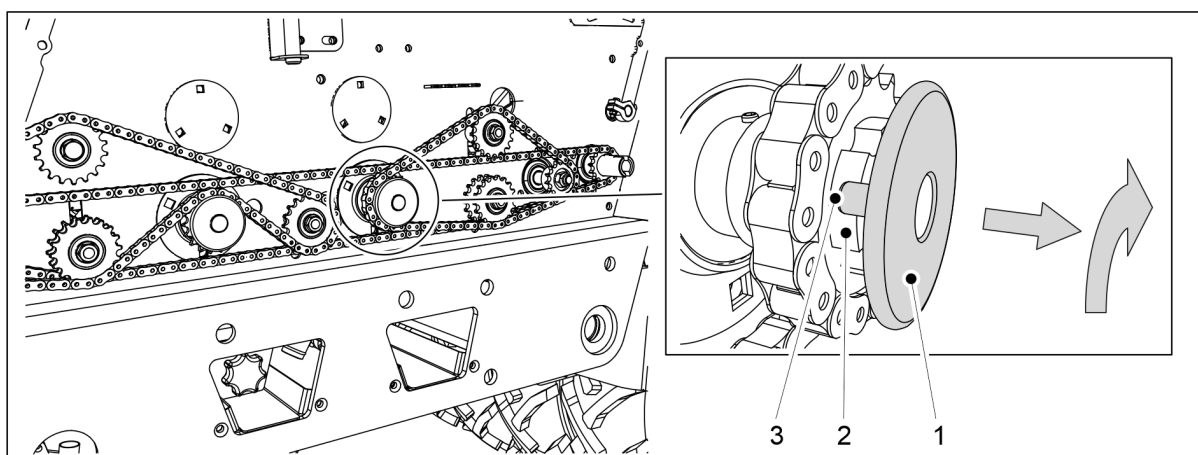

Figure. 6.8.4 - 176. Seed feeder deactivation

5. Pull the seed feeder locking plate (1) outwards and position the locking studs of the disc in line with the grooves (3) of the guide bushing (2).
 - The seed feeder is now deactivated.

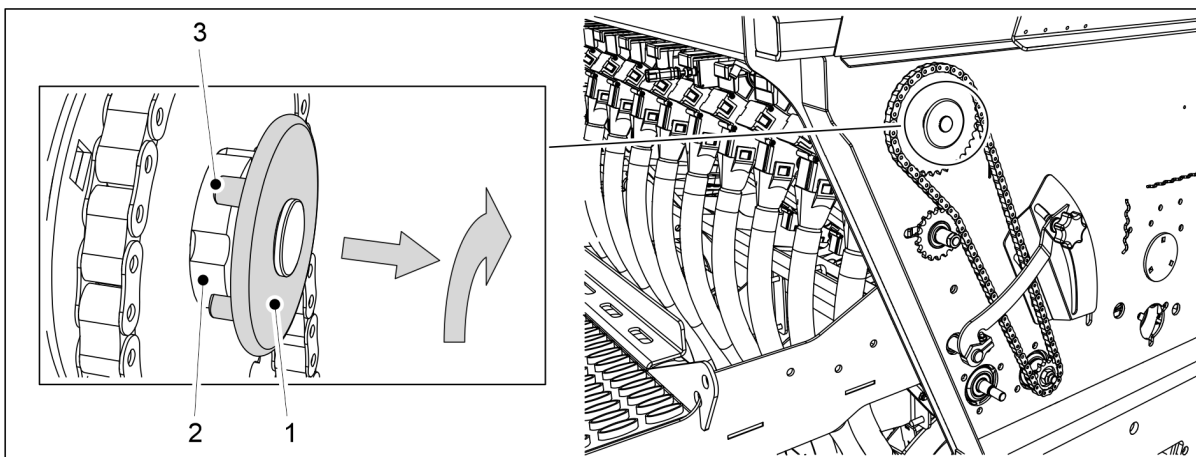

Figure. 6.8.4 - 177. Small seed feeder deactivation

6. If the machine has a small seed hopper: Pull the small seed feeder locking plate (1) outwards and position the locking studs of the disc in line with the grooves (3) of the guide bushing (2).



Figure. 6.8.4 - 178. Setup display

7. On the Setup screen of the user interface, select Product Calibration (1).
- Use the up/down arrow buttons to scroll through the menu. Open the screen by pressing the OK button (2).



Figure. 6.8.4 - 179. Fertiliser target rate

8. Confirm the fertiliser target rate (1) by pressing the SET key (2).



Figure. 6.8.4 - 180. Setting the fertiliser target rate

- The first number starts to flash.
9. Change the value by pressing the up/down arrow keys.
 10. Confirm the value by pressing right arrow key.
- The second number starts to flash.
11. Repeat steps 9–10 for the second and third number.
 12. Press the OK key (1).

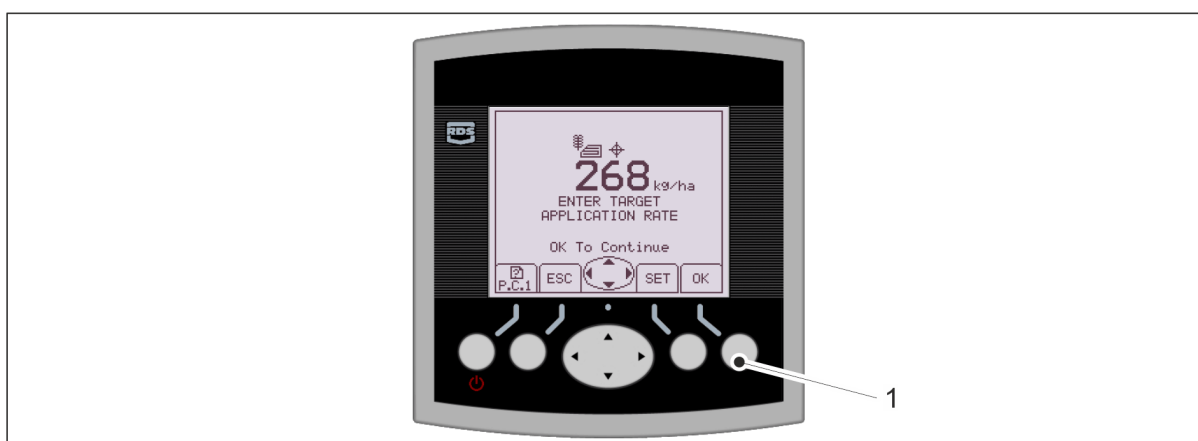

Figure. 6.8.4 - 181. Setting the fertiliser target rate

13. Confirm the fertiliser target rate by pressing the OK key (1).

Product calibration

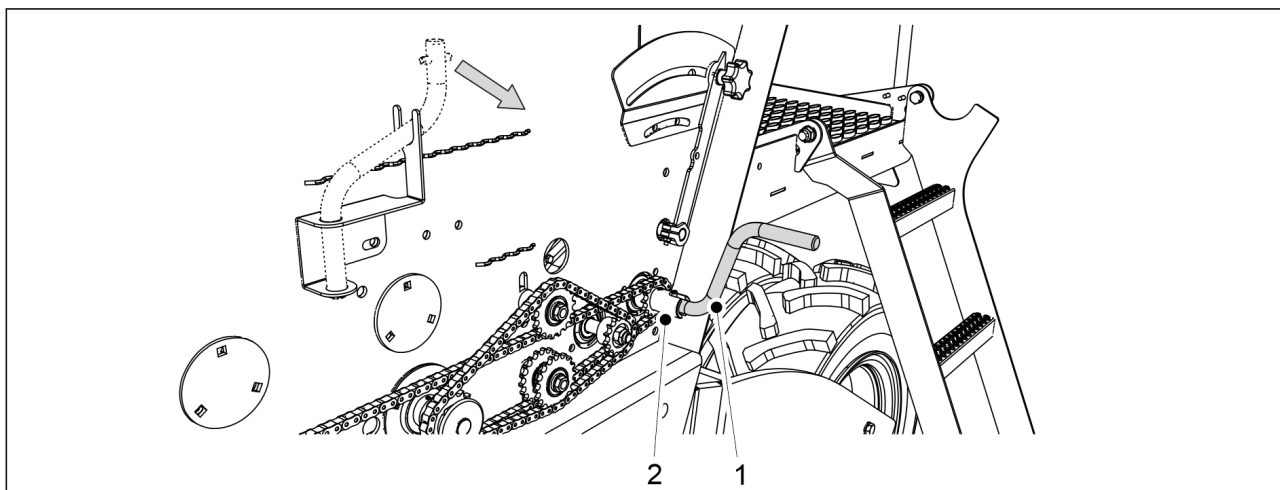

Figure. 6.8.4 - 182. Fastening the calibration test crank

1. Fasten the calibration test crank (1) to the calibration test axle(2).
2. Turn the crank until an even flow of fertiliser comes out of all feeders.
3. Empty the calibration trays.
4. Rotate the axle counterclockwise by 1 turn per second using the calibration test crank.
 - An area of 100 m² is obtained by turning the crank 34 times on the FORTE 300 EVO and 25.5 times on the FORTE 400 EVO.
5. Pull out the calibration trays and weigh the quantities they now contain.
 - Use the calibration test bags and scale delivered with the machine for weighing.
The calibration test quantity obtained corresponds to the area of 100 m² , so the quantities for a hectare will be hundredfold.



Figure. 6.8.4 - 183. Entering the weighing result

- The weighing result is displayed on the screen. The first number starts to flash.
6. Change the value by pressing the up/down arrow keys.
 7. Confirm the value by pressing right arrow key.
 - The second number starts to flash.
 8. Repeat steps 6–7 for the other numbers.
 9. Confirm the correction by pressing the OK key (2).

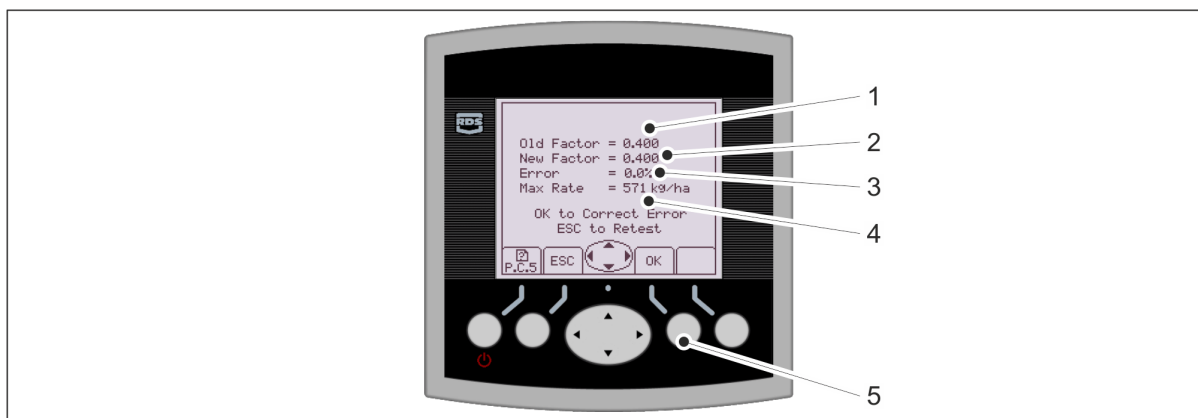

Figure. 6.8.4 - 184. Calibration values for the calibration test

- The old calibration value (1), new calibration value (2), difference between the old and new value (as a percentage) (3) and maximum feed rate (4) are displayed on the screen.

10. Press the OK key (5).

11. Place the calibration trays in the machine. Ensure that the trays are in the correct order and that they are connected to each other correctly.

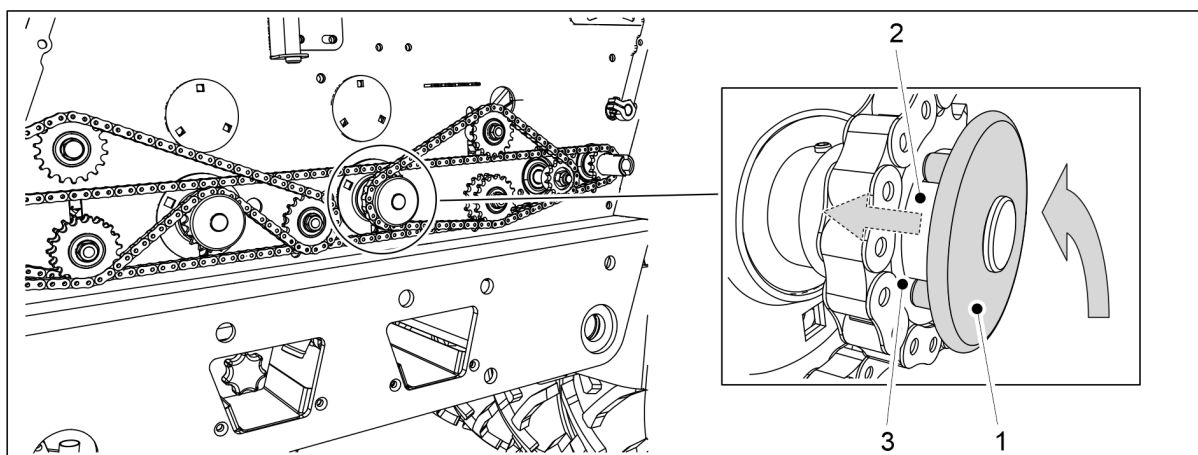

Figure. 6.8.4 - 185. Returning the seed feeder to the operating position

12. Rotate the seed feeders locking disc (1) so that the locking studs of the disc are aligned with the grooves (3) of the guide bushing (2).

- The spring of the shaft pulls the locking disc into place.

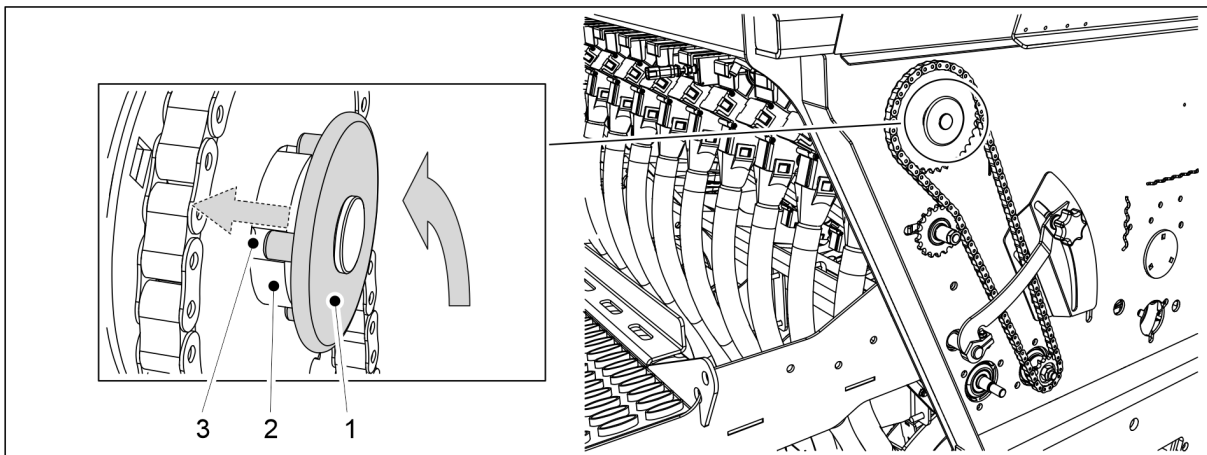

Figure. 6.8.4 - 186. Returning the small seed feeder to the operating position

13. If the machine has a small seed hopper: Rotate the small seed feeders locking disc (1) so that the locking studs of the disc are aligned with the grooves (3) of the guide bushing (2).
 - The spring of the shaft pulls the locking disc into place.

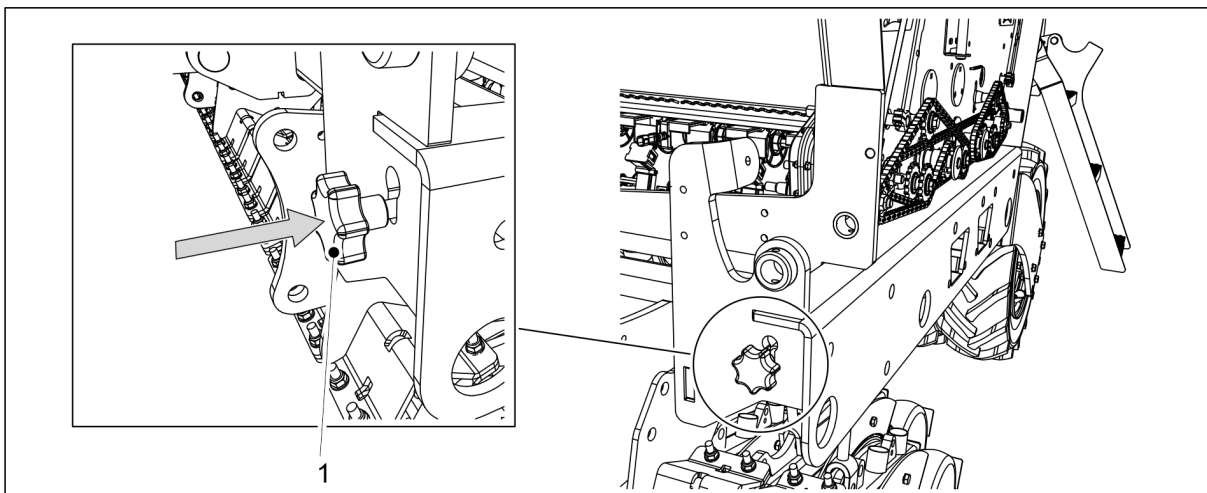

Figure. 6.8.4 - 187. Inserting the calibration test adjuster rod

14. Insert the calibration test adjuster road (1) into the machine frame.
 - Inserting the adjuster rod moves the feeders' flaps to the seeding position.
15. Fold the transmission cover on both sides of the machine.

6.9 Adjusting the seeding depth of the coulters

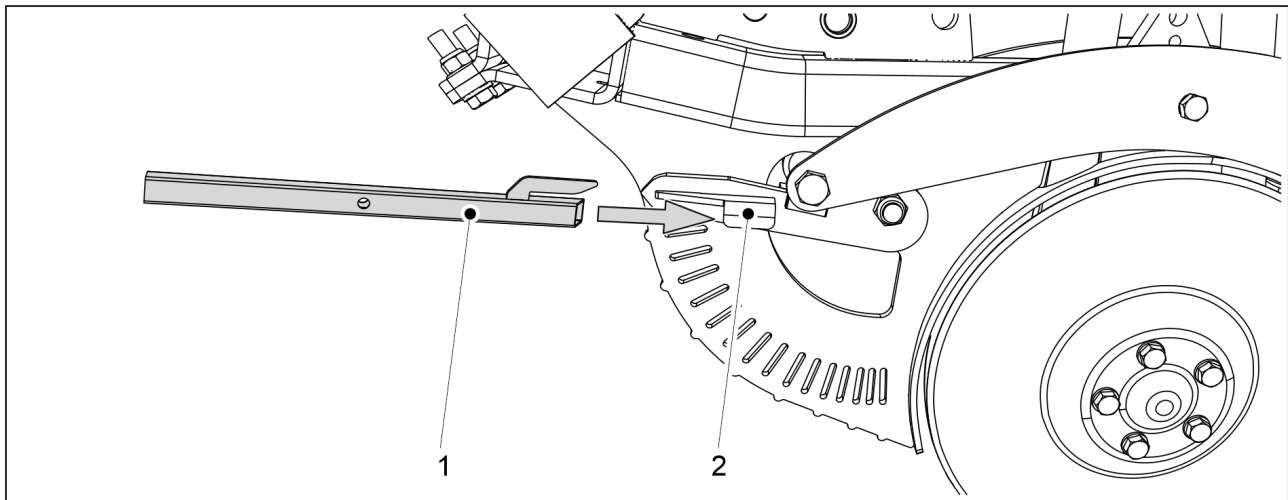

Figure. 6.9 - 188. Coulters adjustment tool

1. Push the coulters adjustment tool (1) onto the lever (2) of the coulters to be adjusted.
 - The adjustment tool is supplied with the machine.

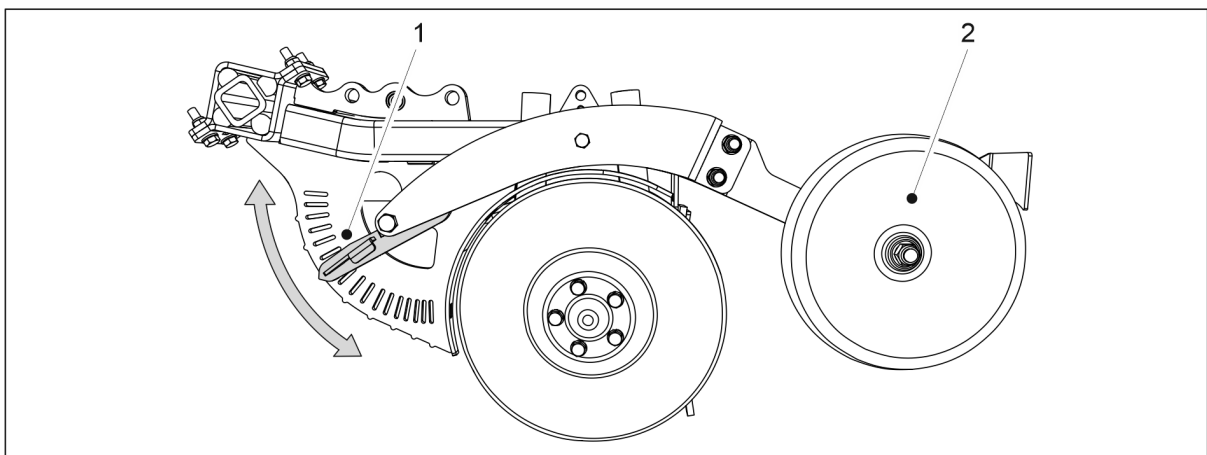

Figure. 6.9 - 189. Adjusting the seeding depth of the coulters

2. Adjust the height of the covering wheel (2) in relation to the coulters by moving lever (1) to the desired slot on the adjuster plate.
 - When the lever is down, the seeding depth is at maximum (i.e. 8 cm).
When the lever is up, the seeding depth is 0 cm.
The height can be adjusted in 0.5 cm increments.
3. Repeat steps 1 and 2 on all coulters.

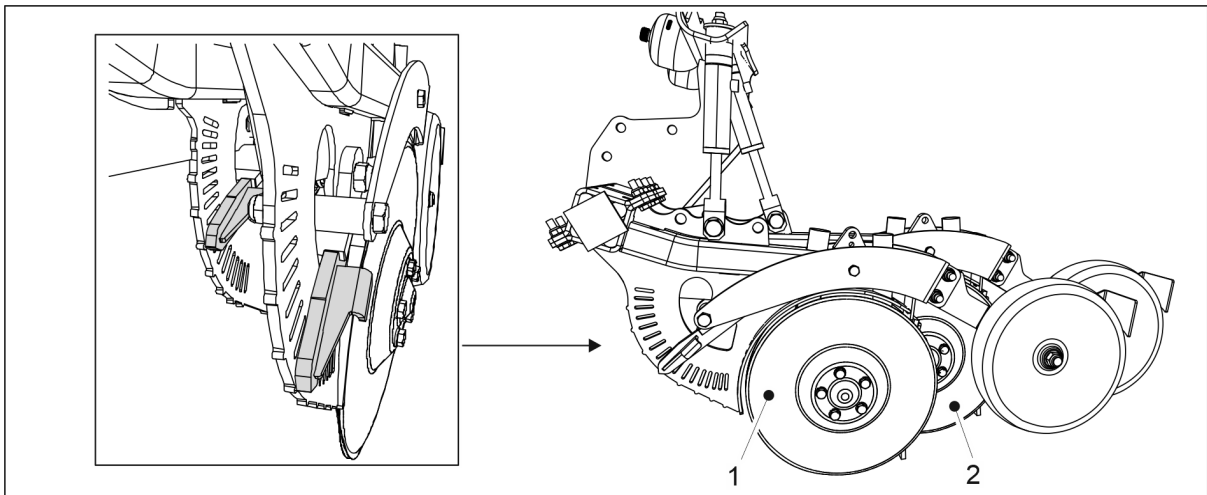

Figure. 6.9 - 190. Foremost and rearmost coulters

- The foremost (1) and rearmost (2) coulters must be adjusted the same. Ensure that the levers are set to the same slot on both adjuster plates.

6.10 Adjusting the coulters pressure

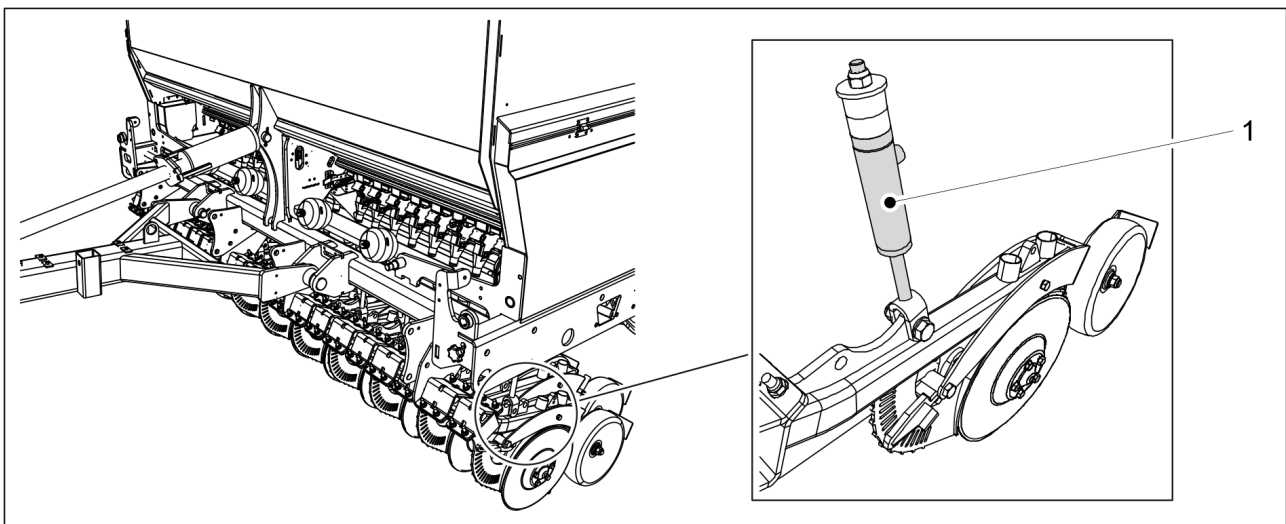

Figure. 6.10 - 191. Adjusting the coulters pressure

1. Adjust the coulters pressure by changing the pressure in the coulters pressure cylinders (1).

- There are 20 pressure cylinders on the FORTE 300 EVO and 26 on the FORTE 400 EVO.

The cylinder presses the frame of the coulter disc down. The system is equipped with pressure accumulators, which allow the coulters to follow contours in the terrain by changing the length of the cylinder stroke.

The coulter pressure adjustment range is 50-250 kg. Use less pressure on light soil and more pressure on hard soil. The pressure should first be set too high and then lowered, if needed, rather than adjusting the pressure too low in the first place. The coulter pressure can be adjusted during operation. For example, it can be decreased at the end of the field with deep soil and increased at the end with clay soil, to maintain the desired seeding depth.

The coulter pressure status can be seen on the coulter pressure gauge (see section [4.1.1.7 Coulter pressure gauge](#)).

6.11 Adjusting the rear harrow

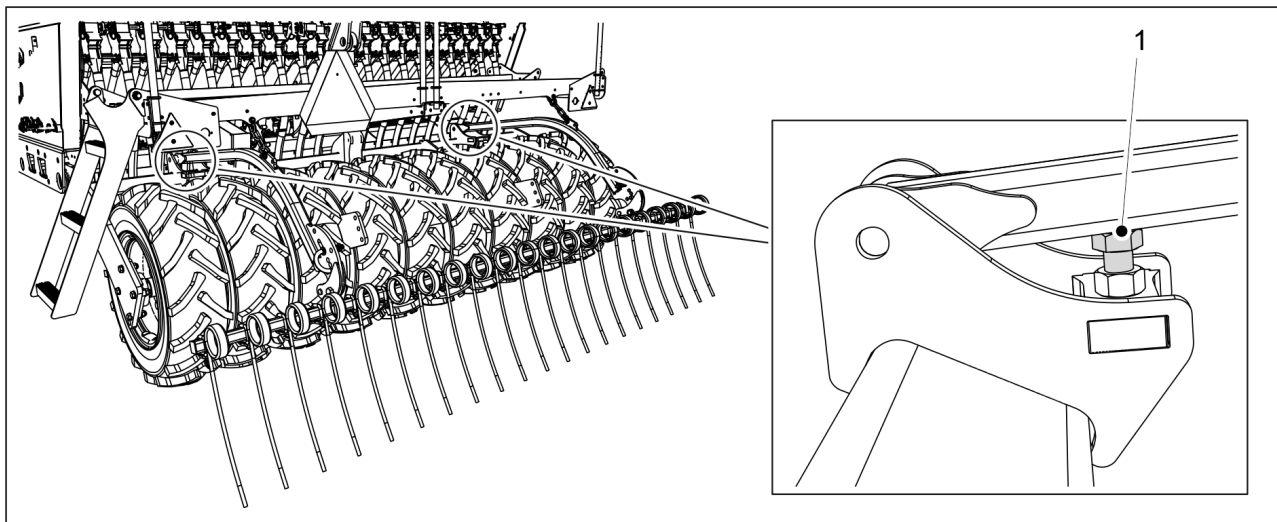

Figure. 6.11 - 192. Adjusting the rear harrow height

1. Use the bolt (1) to adjust the height of the rear harrow.
 - The longer the visible portion of the bolt, the higher the position of the rear harrow.

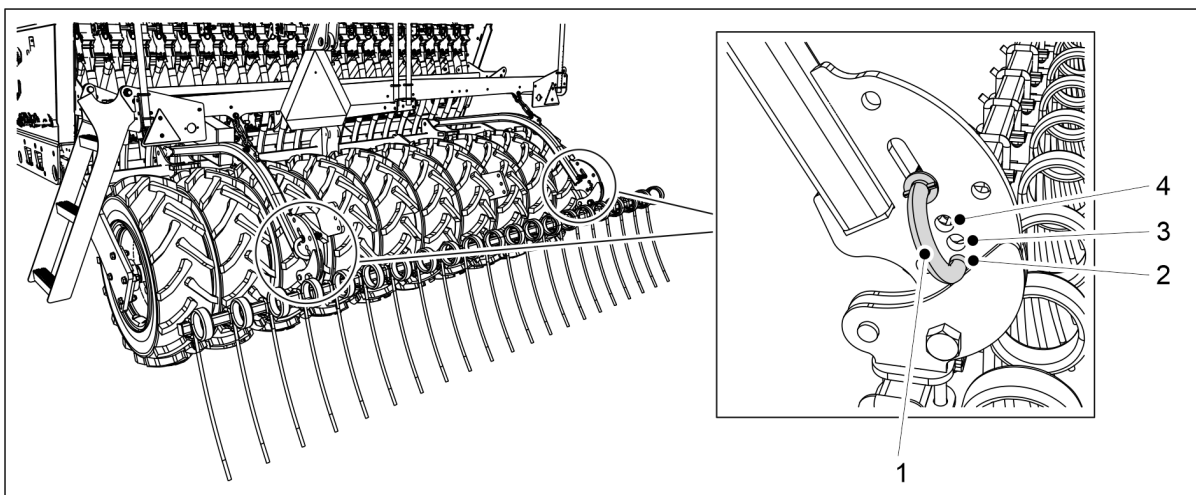

Figure. 6.11 - 193. Adjusting the rear harrow angle

2. Set the rear harrow angle by inserting the bottom end of the adjusting pin (1) into the desired mounting hole (2-4).
 - When the pin is in the bottom hole (2), the rear harrow is in an upright position. This position enables the rear harrow to move the most soil. When the pin is in the top hole (4), the angle of the rear harrow position is the widest. This position is used if there is a lot of mass on the ground. This position enables the rear harrow to penetrate the ground best.

6.12 Adjusting the front levelling board

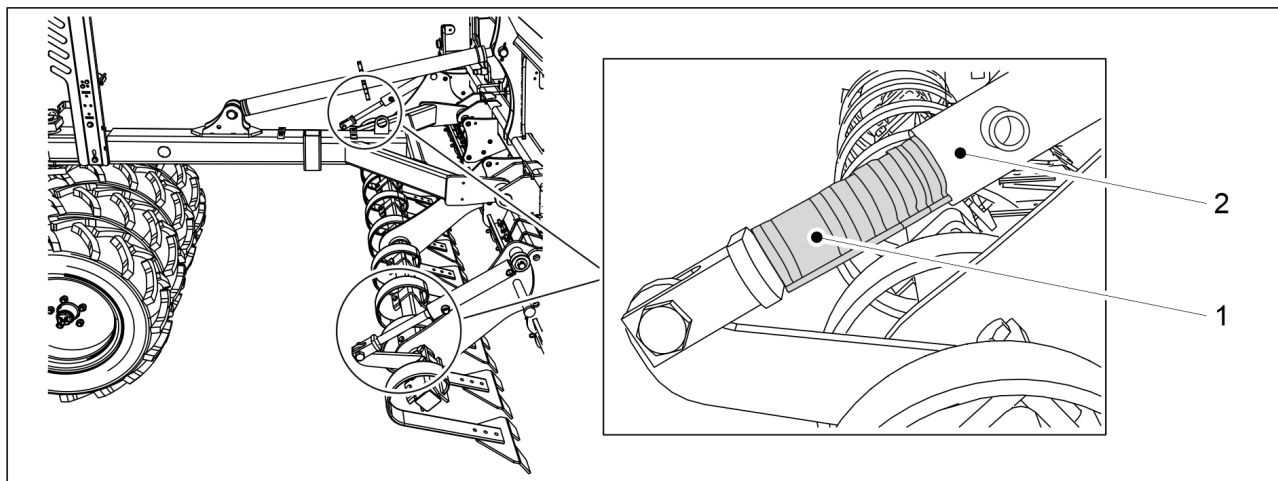

Figure. 6.12 - 194. Adjusting the front levelling board

1. Adjust the height of the front levelling board by placing clips (1) along the shafts of the two hydraulic cylinders of the front levelling board.

Table. 6.12 - 22. The thicknesses and quantities of front levelling board clips

Clip colour	Clip thickness	Quantity
Yellow	31.8 mm	1 pcs
Red	25.4 mm	2 pcs

Black	22.2 mm	2 pcs
Blue	19.2 mm	2 pcs

- The more and the thicker the clips attached to the shaft of the cylinder, the higher the position of the front levelling board.

6.13 Adjusting the front harrow

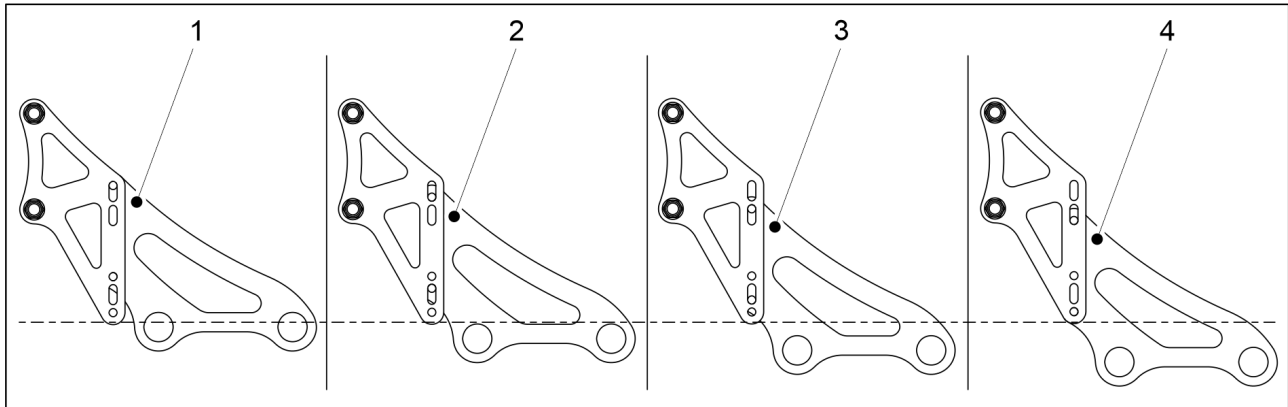

Figure. 6.13 - 195. Front harrow height - options

- The highest position (1) of the front harrow is the factory setting. As the front harrow tines wear, you can set the harrow to lower positions (2-4).

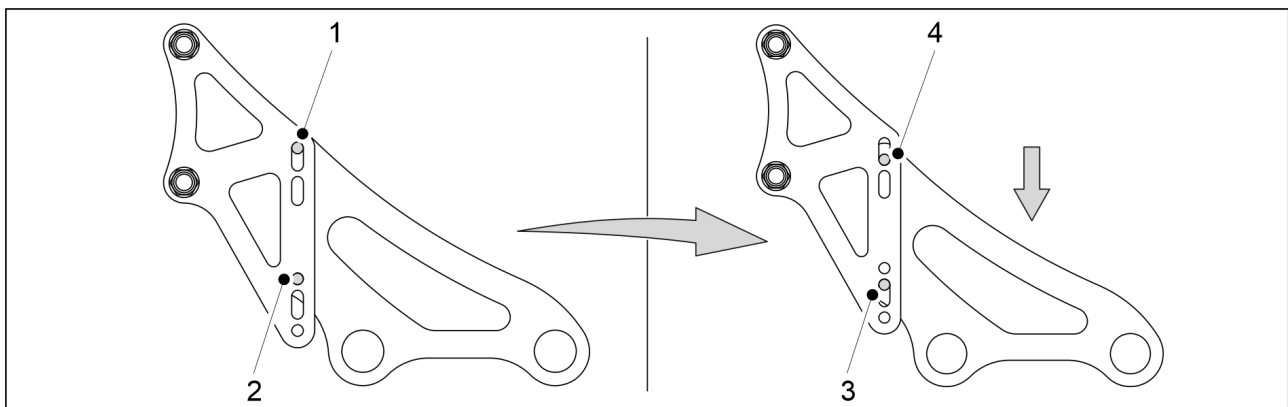

Figure. 6.13 - 196. Adjusting the front harrow height

1. Remove the lower mounting bolt (2) from all four mounts.
2. Loosen the upper mounting bolt (1) on all four mounts.
 - Depending on the starting point of height adjustment on the front harrow, do steps 1 and 2 in reverse order, if necessary.
3. Lower the front harrow onto the loosened mounting bolts until there is no more room for adjustment in either mounting bracket slot (3, 4).
4. Replace the mounting bolts (1 or 2) removed from all four mounts in steps 1 and 2.
5. Tighten all the bolts.

6.14 Adjusting the front disc cultivator

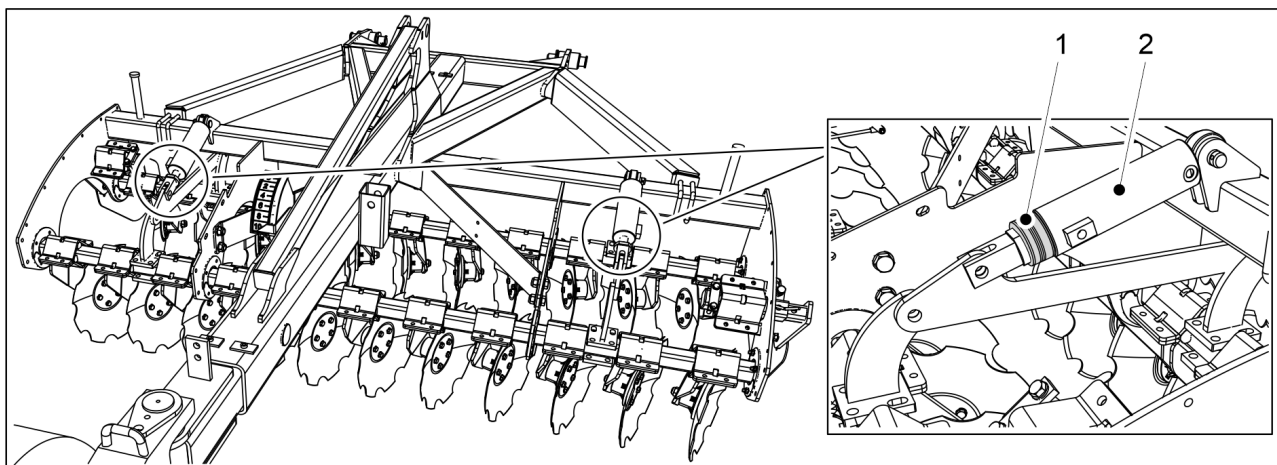

Figure. 6.14 - 197. Adjusting the front disc cultivator tillage depth

1. Adjust the height of the front disc cultivator by placing clips (1) along the rods of the two hydraulic cylinders of the front levelling board.

Table. 6.14 - 23. The thicknesses and quantities of front disc cultivator clips

Clip colour	Clip thickness	Quantity
Yellow	31.8 mm	1 pc
Red	25.4 mm	2 pcs
Black	22.2 mm	2 pcs
Blue	19.2 mm	2 pcs

- The higher the number and the thicker the clips attached to the cylinder rod, the smaller the tillage depth of the front disc cultivator.

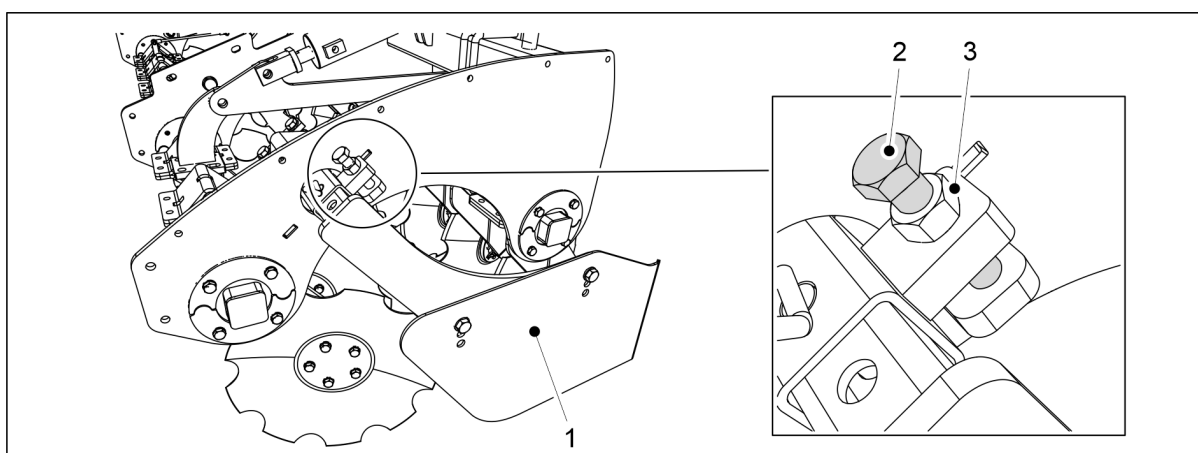

Figure. 6.14 - 198. Adjusting the lower position of side limiters

2. Loosen the side limiter (1) adjuster lock nut (3).
3. Turn the adjuster bolt (2).

- The side limiter moves to the desired lower position.

4. Tighten the lock nut (3).
5. Repeat steps 2-4 on the other side of the front disc cultivator.

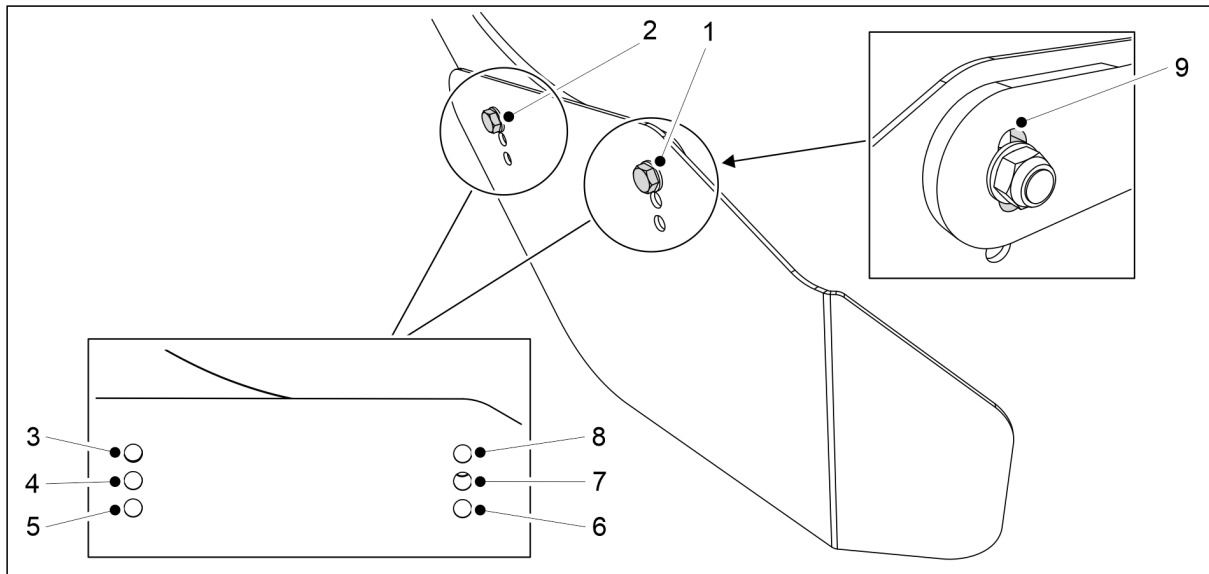

Figure. 6.14 - 199. Adjusting the height and angle of the side limiters

6. Adjust the height and angle of the side limiters by inserting the mounting bolts (1, 2) in the most suitable mounting holes (3-8) for the intended use.
 - If necessary, use the available room for adjustment for the screw (1) in the mounting bracket hole (9).
7. Repeat step 6 on the other side of the front disc cultivator.

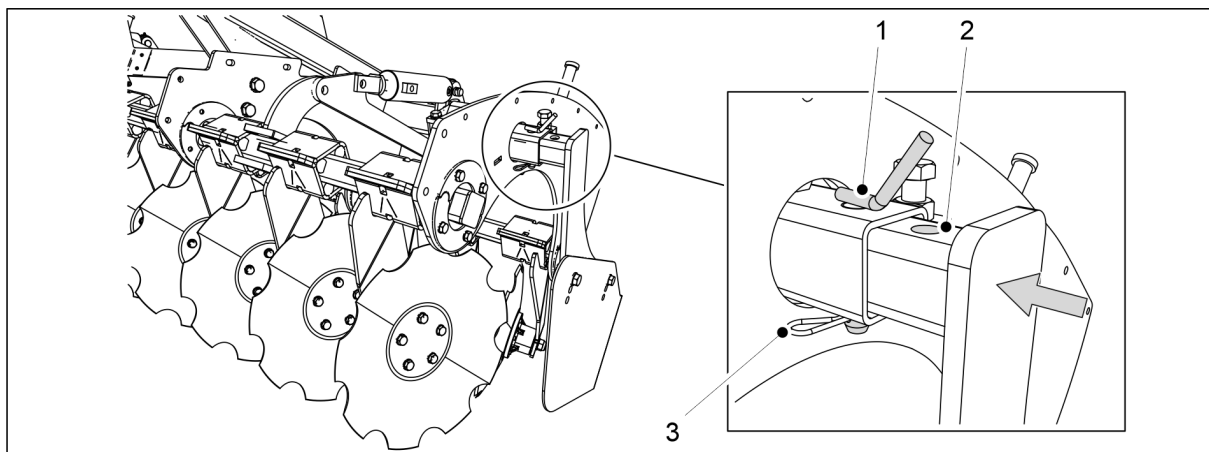

Figure. 6.14 - 200. Adjusting the front disc cultivator side limiters for transport

8. Remove the cotter (3).
9. Lift out the locking pin (1).
10. Push the side limiter inward until the mounting hole (2) is lined up with the support tube (1).
11. Replace the locking pin and cotter.
12. Repeat steps 8-12 on the other side of the front disc cultivator.

6.15 Using the track eradicator

6.15.1 Adjusting the track eradicator height



CAUTION

When adjusting the track eradicator, check that its mounting tube does not catch on the front service platform when adjusting the position of the drawbar.

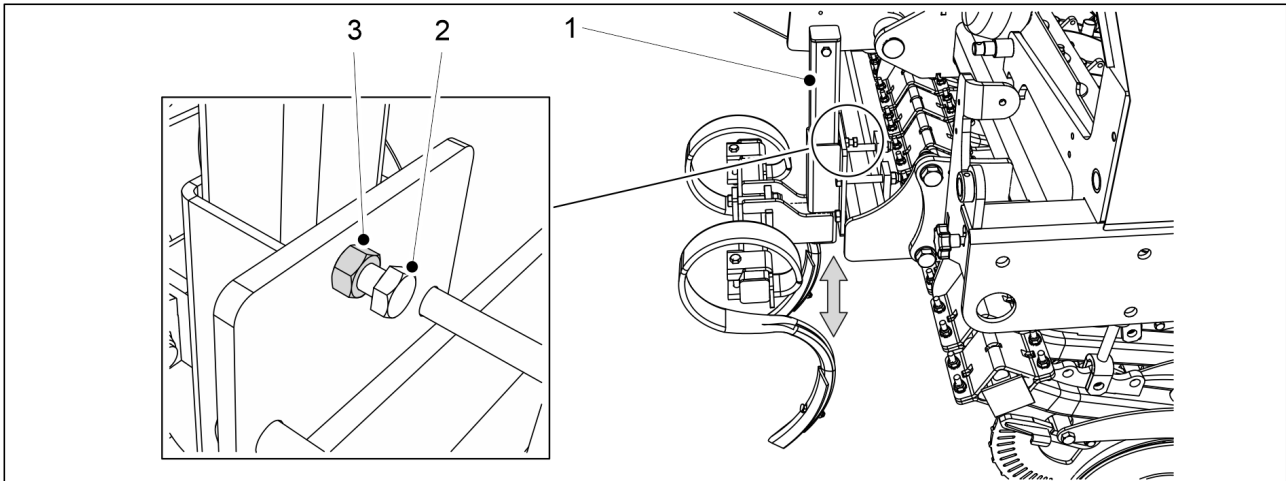

Figure. 6.15.1 - 201. Adjusting the track eradicator height

1. On the left side of the machine, loosen the locking nut (2) on the mounting tube (1) of the track eradicator.
 - TheFORTE 300 EVO machine has 1 set of mounting tubes.
TheFORTE 400 EVO machine has 2 set of mounting tubes.
2. Loosen the bolt (3) slightly until the mounting tube can move.
3. Set the track eradicator to the desired height.
4. Tighten the bolts.
5. Tighten the nuts.
6. Repeat steps 1–5 on the right side of the track eradicator.

6.15.2 Replacing an S-tine point

- Cutting or puncture hazard when changing S-tine points. Exercise extreme caution.

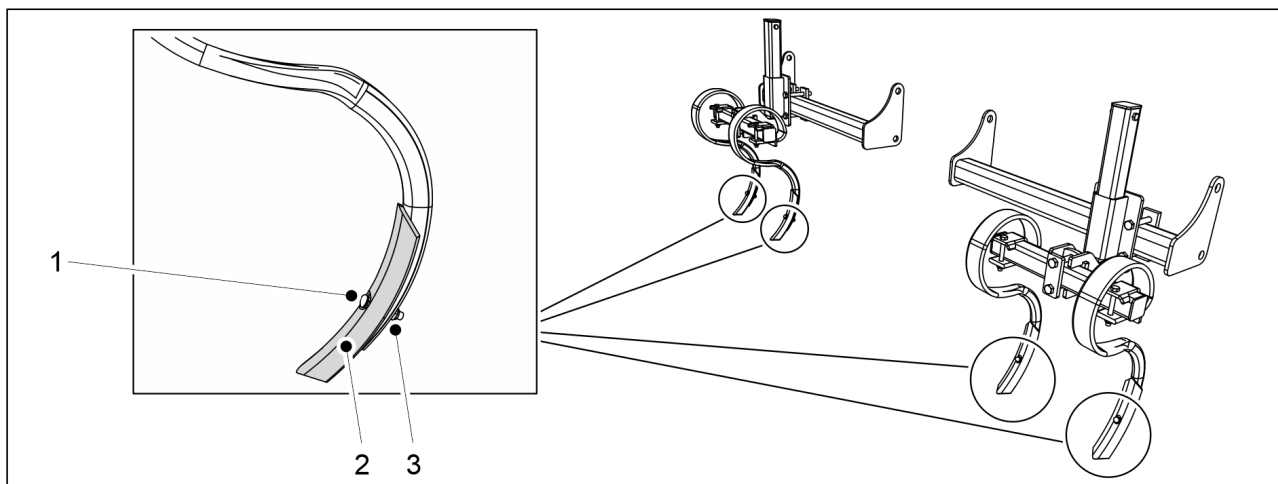

Figure. 6.15.2 - 202. Replacing an S-tine point

1. Loosen the nut (3).
 - The head of the point bolt may become extremely sharp through wear. Never hold the bolt head with your hand when loosening the nut.
2. Remove the bolt (1).
3. Remove the tine point (2).
 - A worn tine point may be flipped around and reattached. Use a new bolt and nut when reattaching.
4. Fasten the new tine point.
 - Use a new bolt and nut when reattaching.

6.16 Use of dispersing axles

A dispersing axle is a device placed in the hopper of a seed drill to prevent the fertiliser or seed from bulging at the feeder inlet.

6.16.1 Use of the fertiliser dispersing axle

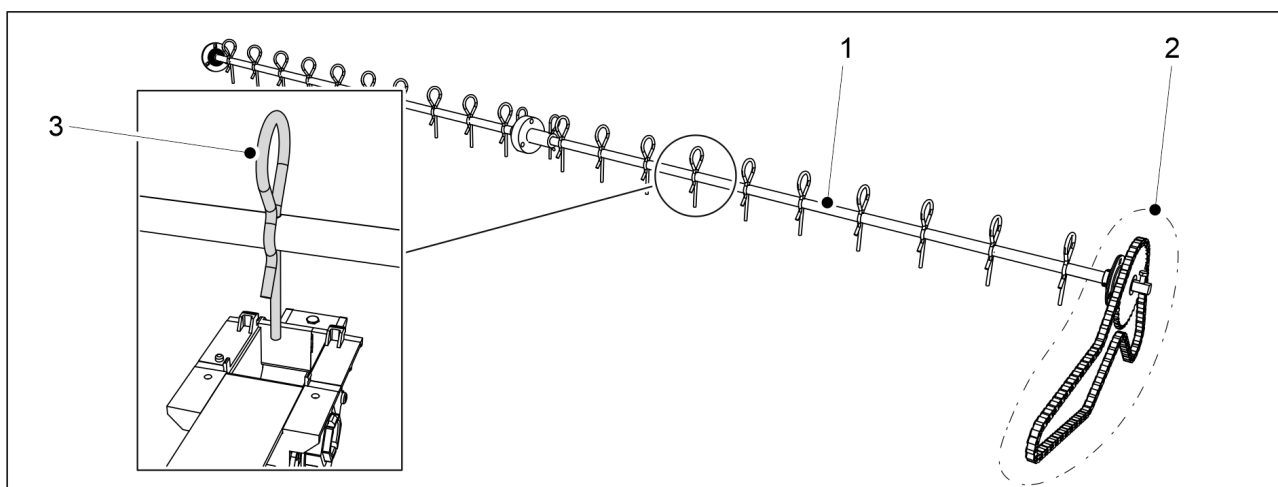

Figure. 6.16.1 - 203. Fertiliser dispersing axle

The fertiliser dispersing axle (1) is connected to the machine's transmission by its own chain (2). The dispersing axle therefore always rotates when the machine is running.

A dispersing tine (3) is attached to the dispersing axle at each fertiliser feeder.

- If so desired, the dispersing tines can be removed from the axle.

6.16.2 Use of the seed dispersing axle

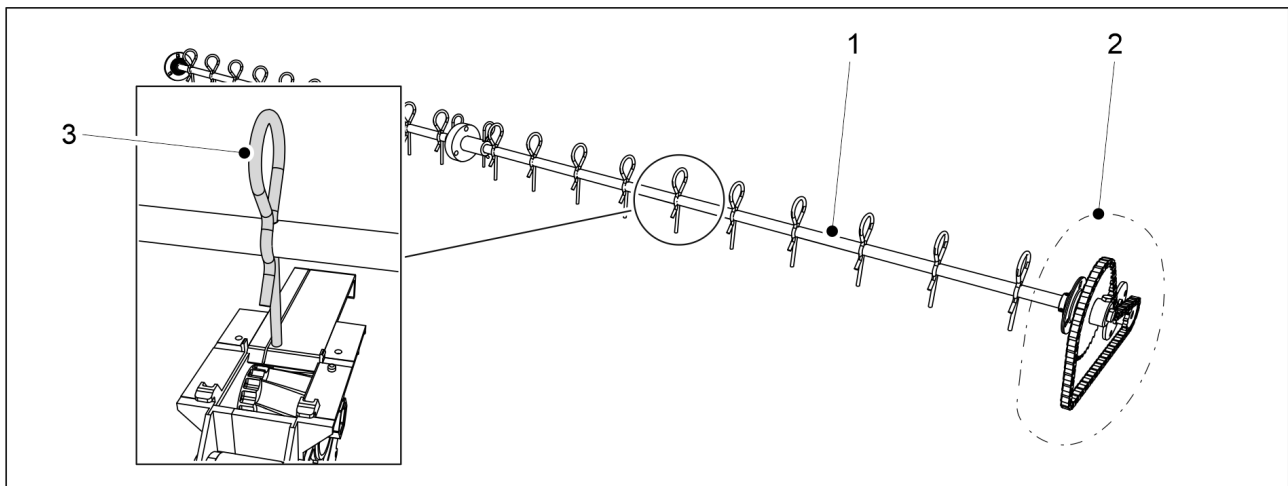

Figure. 6.16.2 - 204. Seed dispersing axle

The seed dispersing axle (1) is connected to the machine's transmission by its own chain (2). The dispersing axle therefore always rotates when the machine is running.

A dispersing tine (3) is attached to the dispersing axle at each seed feeder.

- If so desired, the dispersing tines can be removed from the axle.

6.16.3 Use of a small seed pendulum disperser



CAUTION

The tip of the pendulum disperser's dispersion tine extends slightly inside the inlet of the small seed feeder. If you wish to use the small seed feeder with a shut-off plate in the closed position, remove the pendulum disperser's dispersing tine from the shut-off plate before use to avoid structural damage.

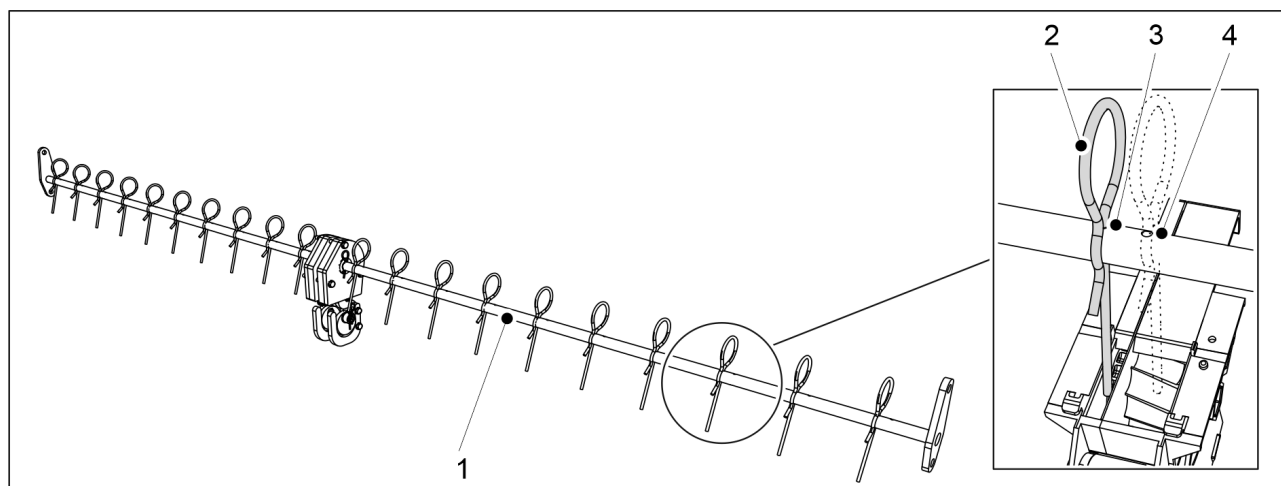

Figure. 6.16.3 - 205. Small seed pendulum disperser

The pendulum disperser (1) is mounted inside the small seed hopper of the machine. The pendulum disperser operates by going backwards and forwards.

A dispersing tine (2) is attached to the dispersing axle at each small seed feeder.

- The pendulum disperser axle has two mounting holes for each dispersing tine: a mounting hole (3) at the narrow shut-off plate and a mounting hole (4) at the wide shut-off plate. If so desired, the dispersing tines can be also removed from the axle.

6.17 Controlling the seeding depth

1. Drive at the normal seeding speed (8- 12 km/h) approximately 10 metres and stop.
2. Stop the tractor, switch off the power and engage the parking brake.
3. Walk to the area you just sowed in the field and sweep loose soil from the surface of the field.
4. Check the depth of the seeding furrow and that there are seeds and fertiliser in the furrow.
 - If needed, adjust the seeding depth in accordance with section [6.9 Adjusting the seeding depth of the coulter](#).

6.18 Securing the position of the middle markers

1. When you drive along the second sowing lane, stop.
2. Stop the tractor, switch off the power and engage the parking brake.
3. Check the distance between the outermost rows of the sowing lanes.
 - The distance between the outermost rows of the seeding rows must be 150 mm on the FORTE 300 EVO and 154 mm on the FORTE 400 EVO.
4. If the distance is incorrect, adjust the middle markers in accordance with section [5.3.8 Adjusting the middle markers](#).

6.19 Brake system operation

6.19.1 Using the parking brake

On a seed drill equipped with a brake system, the parking brake (1) is located under the working platform on the left side of the machine.

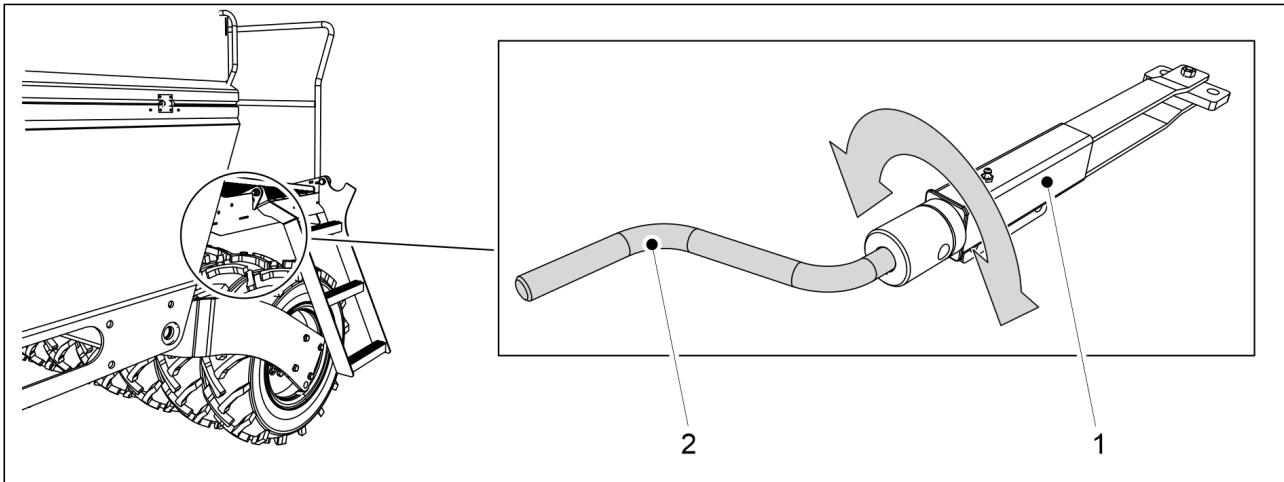

Figure. 6.19.1 - 206. Parking brake

1. Attach the calibration test crank (2) to the parking brake.
 - The calibration test crank is supplied with the machine. The crank is located behind the transmission cover on the left side of the machine.
2. Engage the parking brake by turning the crank (2) clockwise.
 - Turn the crank until there is a great deal of resistance. The brake levers will then no longer move.
3. Release the parking brake by turning the crank (2) counterclockwise.
 - Always turn the crank all the way to the end. Once there, the crank will no longer move.

6.19.2 Releasing brakes

- These instructions only apply to seed drills equipped with a pneumatic brake system.

Pneumatic brakes can be released with a brake release valve when the seed drill's pneumatic brake system is not connected to the tractor's pneumatic brake system.

The brake release valve (1) is located on the drawbar.

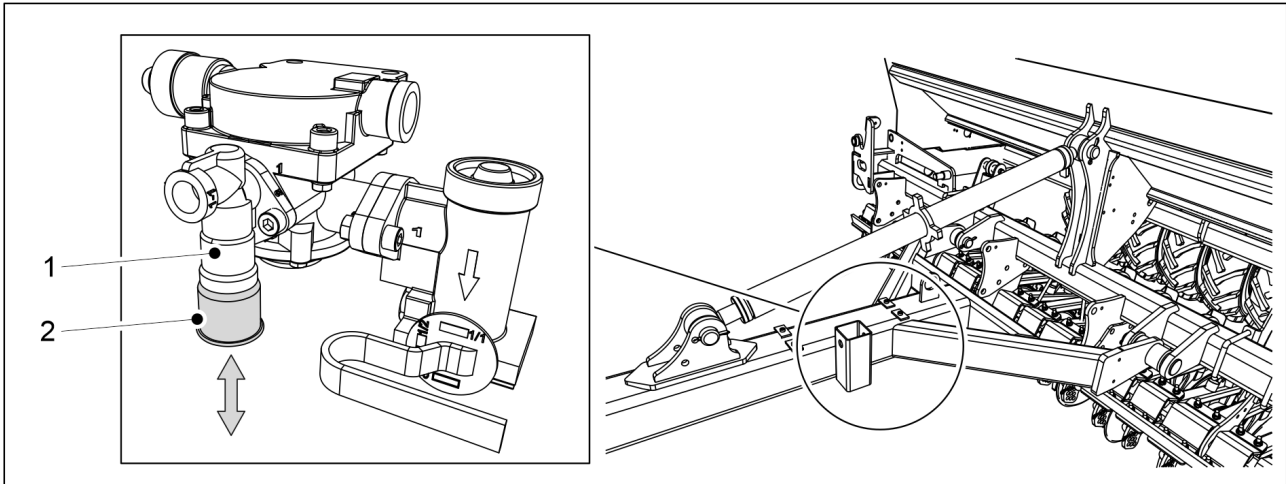

Figure. 6.19.2 - 207. Brake release valve

Release valve button (2) functions:

- the brakes are released by pressing the button (up)
- pulling the button out (down) keeps the brakes engaged if there is any pressure in the pneumatic tank.

Regardless of the button position, the brakes will release when the pressure decreases in the seed drill's pneumatic tank.

- When parking the seed drill, ensure that it will stay in place by engaging the parking brake.

6.19.3 Adjusting braking force

- These instructions only apply to seed drills equipped with a pneumatic brake system.

The braking force needed varies according to the fill level of the hoppers. Braking force can be adjusted with the braking force control valve.

The braking force control valve (1) is located on the drawbar.

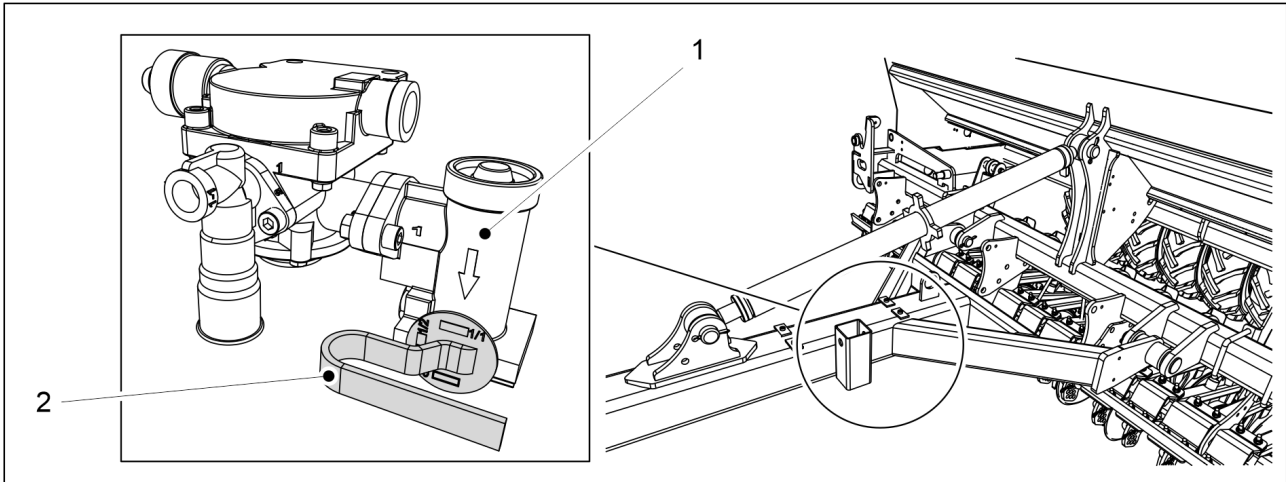

Figure. 6.19.3 - 208. Braking force control valve

1. Turn the control valve lever (2) to the appropriate position.

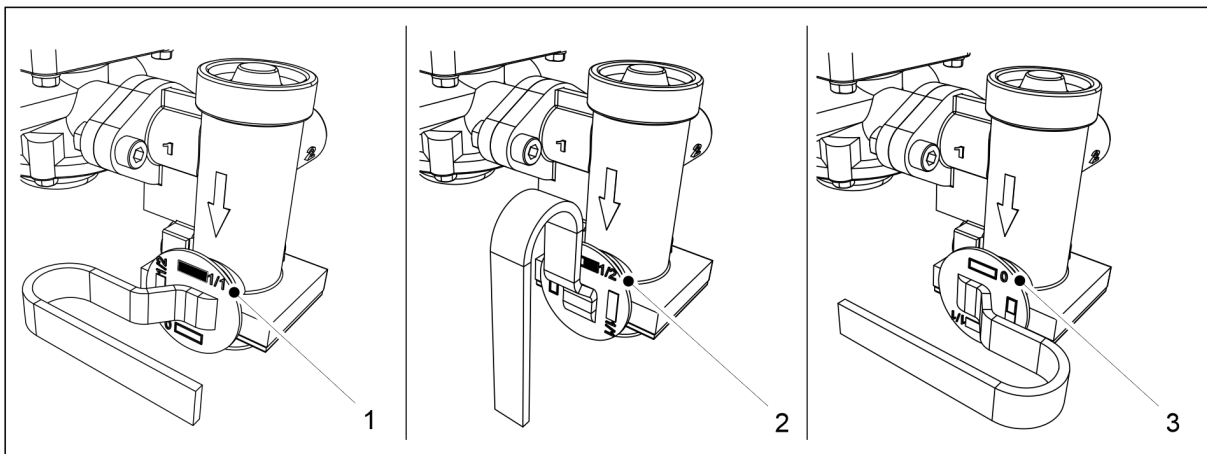

Figure. 6.19.3 - 209. Braking force control valve positions

- When the hoppers are full, turn the lever to position (1).
When the hoppers are half full, turn the lever to position (2).
When the hoppers are empty, turn the lever to position (3).

6.20 Emptying the hoppers

6.20.1 Emptying the hoppers to the calibration tray

- If the hopper is almost empty, the seed or fertiliser is directed to the calibration tray through the feeders and the tray is emptied. Instructions on performing the calibration test are provided in section [6.8 Product calibration](#).

6.20.2 Emptying the hoppers through the coulters

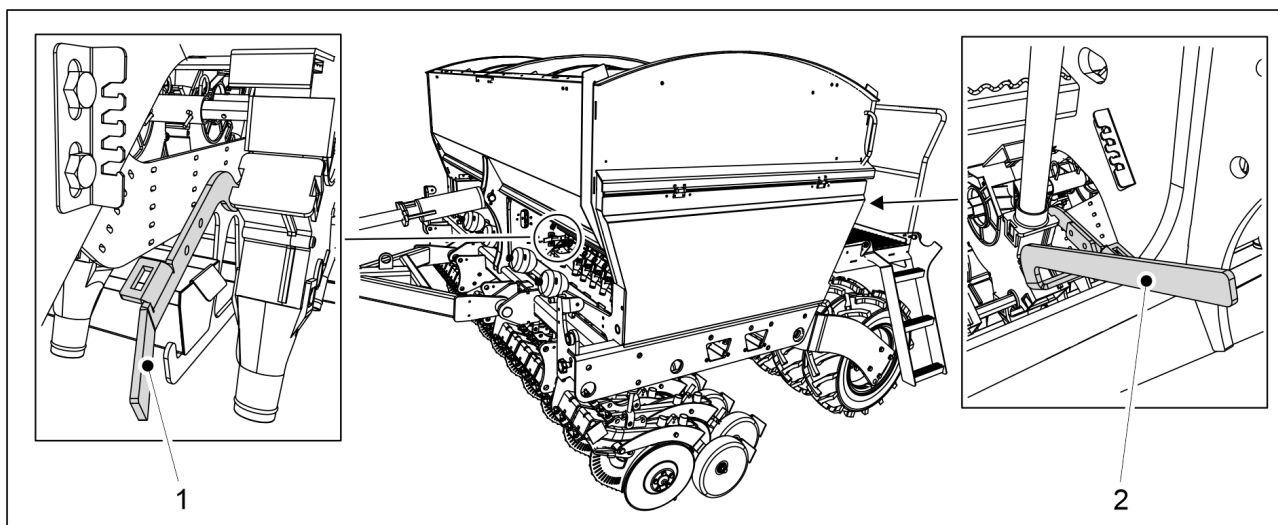

Figure. 6.20.2 - 210. Opening the bottom flaps of the hoppers

1. Open the bottom flap of the hopper to be emptied using the control lever (control lever (1) is for the fertiliser hopper and control lever (2) is for the seed hopper).
 - FORTE 300 EVO: 1 set of both control levers in the middle of the machine.
 - FORTE 400 EVO: 2 sets of both control levers (1 in the middle of each half of the hopper).

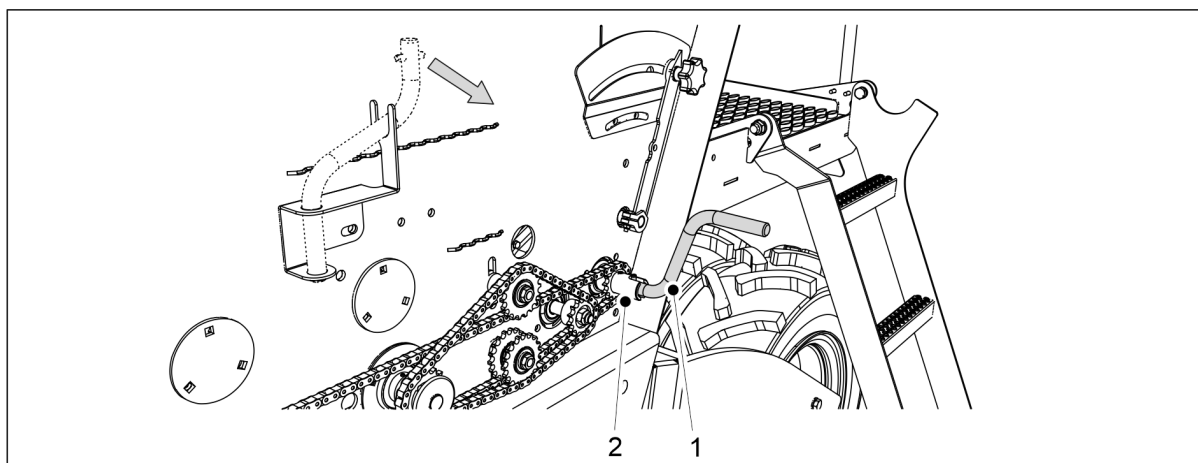

Figure. 6.20.2 - 211. Calibration test crank

2. Fasten the calibration test crank (1) to the calibration test axle(2).
3. Use the calibration test crank to rotate the feeders.
 - Emptying can be enhanced with compressed air to blow all seeds and fertiliser out of the hoppers and feeders.

6.21 Emptying the small seed hopper

6.21.1 Emptying the hopper to the calibration tray

- If the small seed hopper is almost empty, the seeds are directed to the calibration tray through the feeders and the tray is emptied. The calibration test of small seed hopper is provided in section [6.8.3 Small seed calibration test](#).

6.21.2 Emptying the small seed hopper through pipes

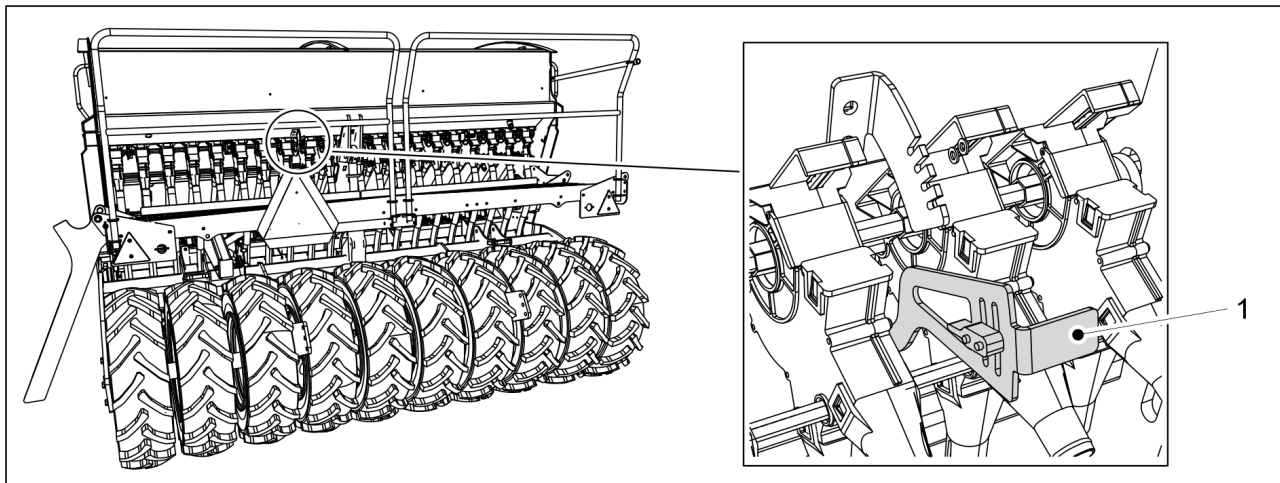

Figure. 6.21.2 - 212. Opening the bottom flap of the small seed hopper

1. Open the small seed hopper bottom flap by turning the control lever (1) downward.

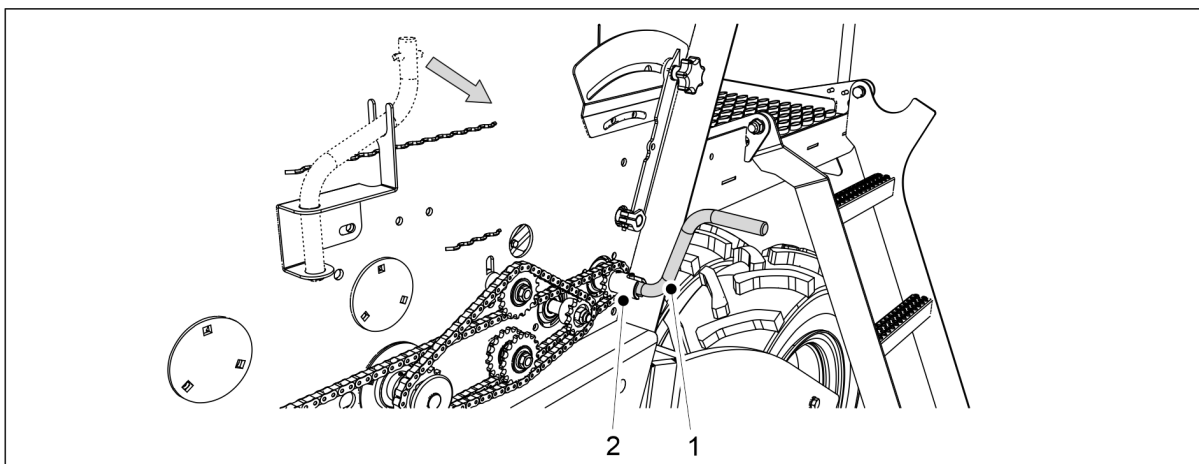

Figure. 6.21.2 - 213. Calibration test crank

2. Use the calibration test crank (1) to rotate the feeders.
 - Emptying can be enhanced with compressed air to blow all seeds and fertiliser out of the hoppers and feeders.

6.22 Disconnecting from the tractor



DANGER

Crushing hazard when connecting and disconnecting the seed drill. Safety distance 5 m. Be extremely careful if someone else is near the seed drill and tractor giving instructions on connecting and disconnecting.



DANGER

Ensure that the tractor is turned off and the key is removed from the ignition.

1. Open the machine lifting circuit ball valve in accordance with the instructions in section [5.3.5 Using the machine lifting circuit ball valve](#).
2. Disconnect the electric connections of the seed drill.
3. Disconnect the hydraulic hoses of the seed drill from the tractor.



DANGER

Depressurise the hydraulic system before disconnecting it. Follow the tractor manufacturer's instructions.



DANGER

Wear protective gloves when disconnecting the hydraulics.

4. Disconnect the drawbar of the seed drill from the tractor's hitch or the wheel packer from the tractor's link arms.

6.23 Machine storage

1. Clean the machine in accordance with section [7.3 Cleaning](#).
 - Damaged paint can be touched up after washing.
2. Lubricate all lubrication points in accordance with section [7.2 Lubrication](#).
3. Protect painted surfaces, galvanised parts and cylinder rods by lightly oiling them with a protective oil intended for this purpose.
4. For seasonal storage of the machine, use a dry place protected from sunlight.

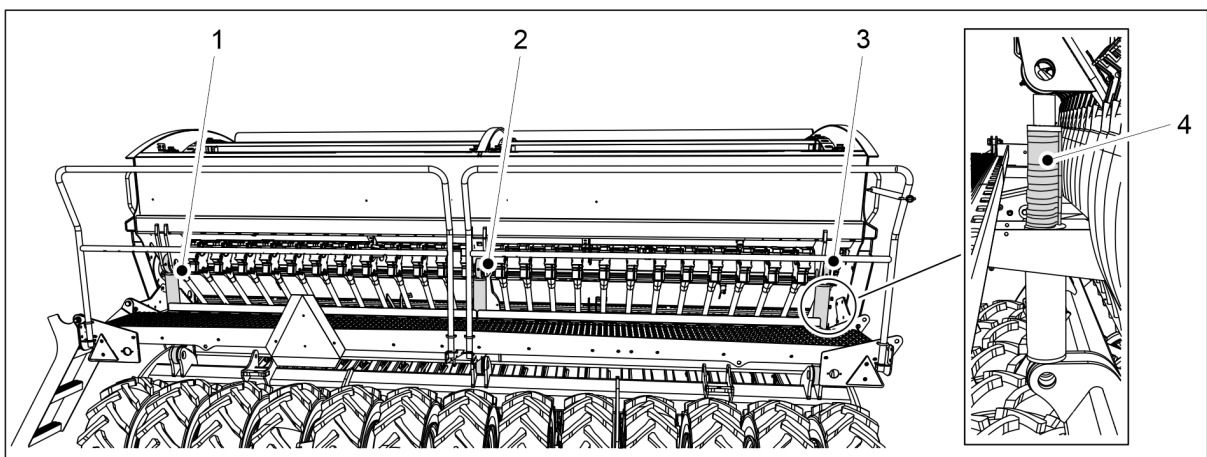

Figure. 6.23 - 214. Cylinder stoppers

5. Place the 4 stoppers (4) on the lifting cylinder rod so that the coulters are slightly raised off the ground.
 - The FORTE 300 EVO has 1 lifting cylinder (2), onto which the stoppers are placed. The FORTE 400 EVO has 3 lifting cylinders (1-3). The stoppers are placed on the outermost cylinders (1, 3).
6. Ensure that the feeder shut-off plates have not been pushed fully closed.
7. Depressurise the coulter pressure circuit by holding the tractor valve open for approx. 10 seconds.
 - The coulter pressure status can be seen on the coulter pressure gauge (see section [4.1.1.7 Coulter pressure gauge](#)).
8. Use wheel wedges or blocks to prevent the machine from moving during long-term storage.

7 Maintenance



DANGER

Depressurise the hydraulic system, disconnect the hoses and tractor's electrical connections and let the machine cool off before servicing.



DANGER

There is a crushing and cutting hazard in the machine's transmission when performing servicing and maintenance. Switch off power in the tractor, remove the key from the ignition and engage the parking brake before servicing.

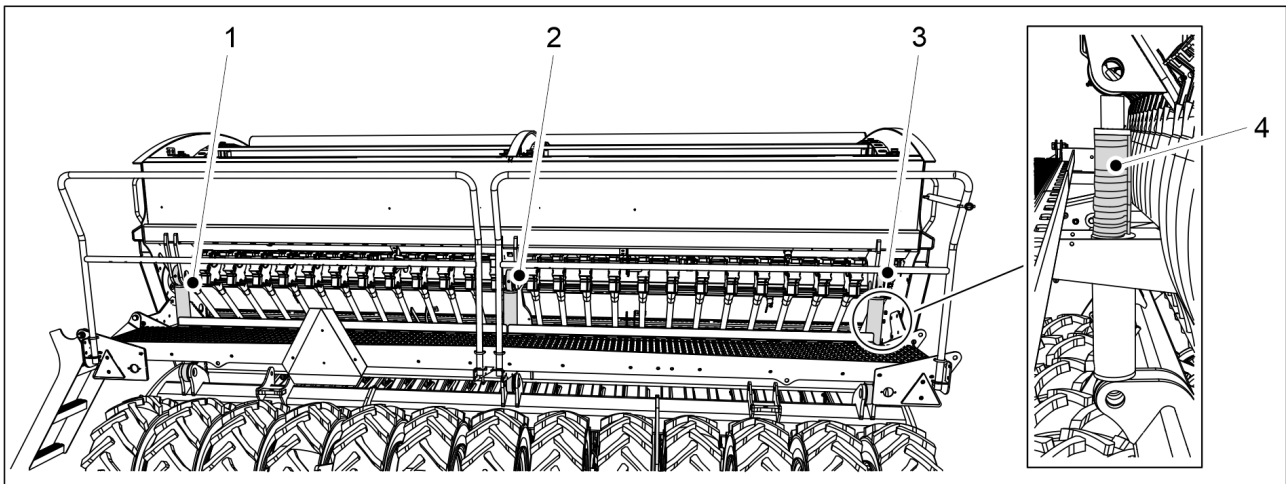

Figure. 7 - 215. Cylinder stoppers



DANGER

There is a crushing hazard when performing servicing and maintenance. Place 4 stoppers (4) on the lifting cylinder rods. The FORTE 300 EVO has 1 lifting cylinder (2), onto which the stoppers are placed. The FORTE 400 EVO has 3 lifting cylinders (1-3). The stoppers are placed on the outermost cylinders (1, 3). Place a stand or other suitable support under the machine. Never go under the machine that is not propped up.



DANGER

Close the machine lifting circuit ball valve in accordance with section 5.3.5 Using the machine lifting circuit ball valve.



DANGER

There is a crushing hazard underneath the machine and a cutting hazard in the machine's transmission when performing servicing and maintenance. Before servicing, make sure that power is switched off in the tractor, the key is removed from the ignition and the parking brake is engaged.



DANGER

If the machine is equipped with middle markers, ensure that they have settled into their transport position and their ball valves are closed, as specified in section 3.4 Using the middle marker ball valves.

7.1 Inspections

7.1.1 Quick instructions, inspections

The inspections to be performed on the seed drill are shown in the table below. The inspections to be carried out once per operating season must be performed in the spring when the machine is commissioned after winter storage.

Table. 7.1.1 - 24. Inspections to be performed on the seed drill

	1) After the first 10 hectares	2) Every 50 hectares	3) Every 500 hectares or once per operating season
<u>7.1.2 Checking bolt tightness</u>	X		X
<u>7.1.3 Checking tyre pressure</u>		X	X
<u>7.1.4 Checking the bearing clearance of the wheel packer hubs</u>			X
<u>7.1.5 Checking the tightness of the transmission chains</u>	X		X
<u>7.1.6 Checking the tightness of the wheel drive chain</u>	X		X
<u>7.1.7 Inspecting the wheel drive clutch</u>			X
<u>7.1.8 Inspecting the wheel drive clutch</u>	X		X
<u>7.1.9 Checking the condition of hydraulics</u>			X
<u>7.1.10 Checking the condition of electric wires</u>			X
<u>7.1.11 Inspecting the towing eye</u>			X
<u>7.1.12 Checking the gearbox oil level</u>			X
<u>7.1.13 Inspecting the coulter discs</u>			X
<u>7.1.14 Checking the functioning of the adjusting of the fertiliser target rate</u>			X

7.1.2 Checking bolt tightness

7.1.2.1 Checking the tightness of the wheel bolts of the transport wheels

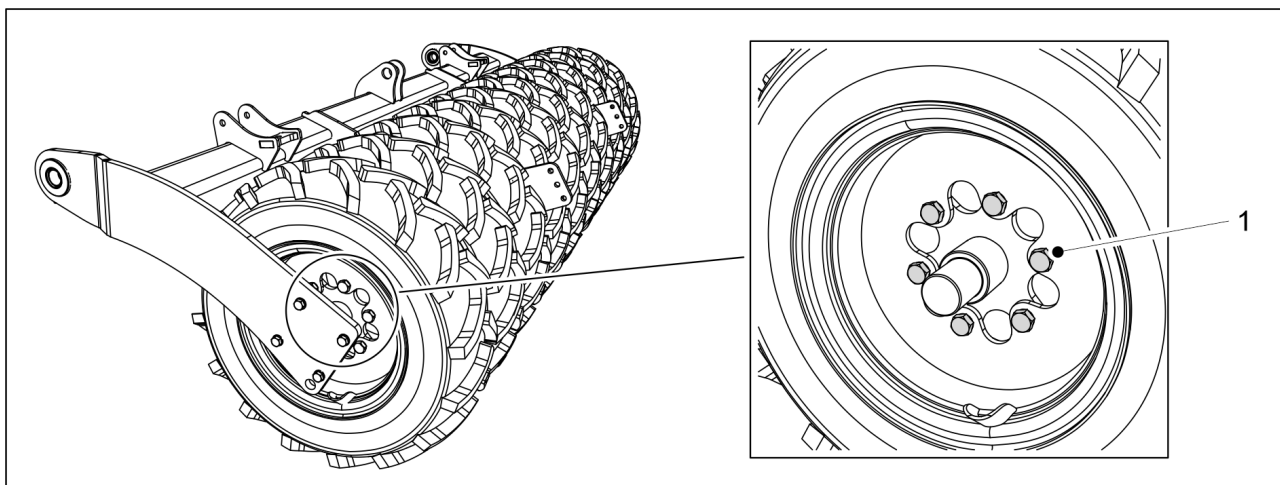

Figure. 7.1.2.1 - 216. Wheel bolts of the transport wheels

1. Check that all the M20 x 1.5 wheel bolts (1) of the transport wheels are tight.
 - Each transport wheel has 6 bolts. There are 10 transport wheels on the FORTE 300 EVO and 13 on the FORTE 400 EVO.
Tighten the bolts, if needed. If the gap between the tyres is narrow, tighten the bolts from the next gap by using a ratchet and a handle.
The bolts have been factory-installed with a locking compound.

7.1.2.2 Checking the tightness of the bolts in the flange bearings of the transport wheels

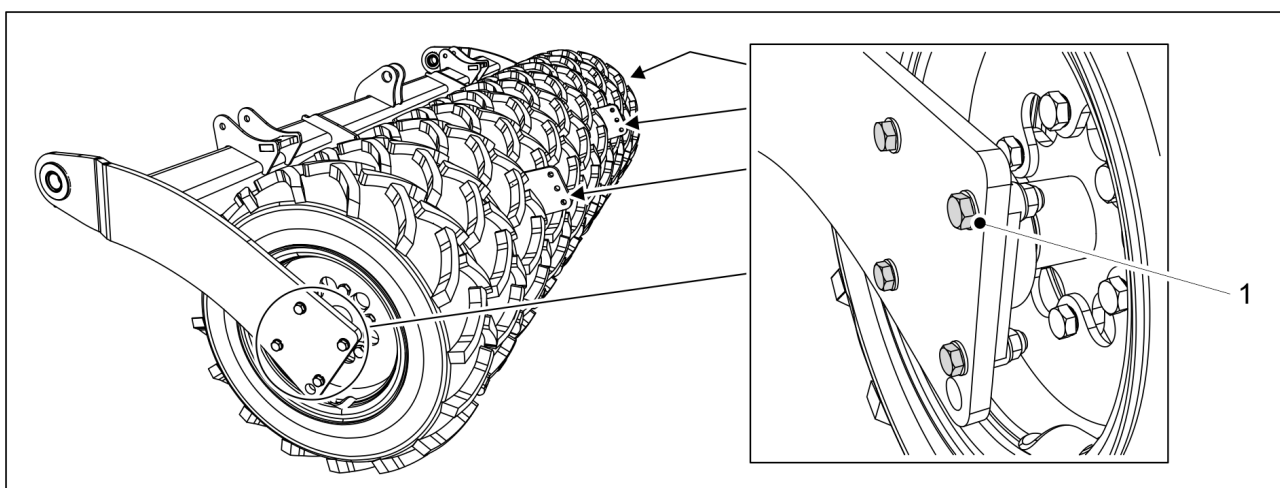

Figure. 7.1.2.2 - 217. The flange bearing bolts of the transport wheels

1. Check that all the 24 M16 flange bearing bolts (1) of the transport wheels are tight.

- Each bearing has four bolts. There are six bearings.
Tighten the bolts, if needed. If the gap between the tyres is narrow, tighten the bolts from the next gap by using a ratchet and a handle.

7.1.2.3 Checking the tightness of the wheel bolts of the wheel packer

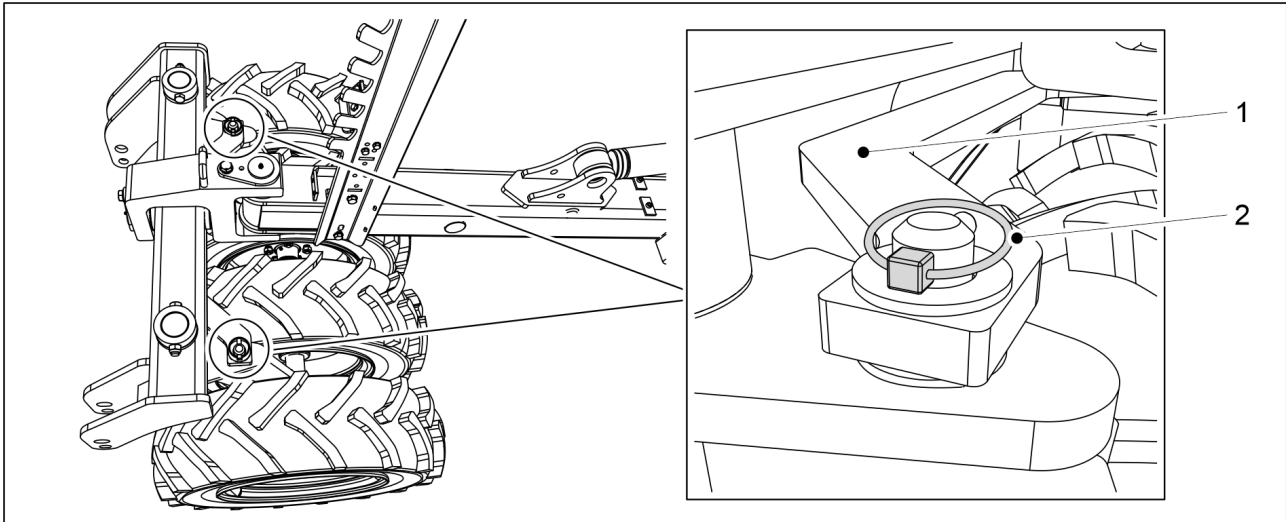

Figure. 7.1.2.3 - 218. Wheel packer bar

1. Detach the two cotters (2) of the wheel packer bar (1).
2. Detach the wheel packer bar by lifting it.

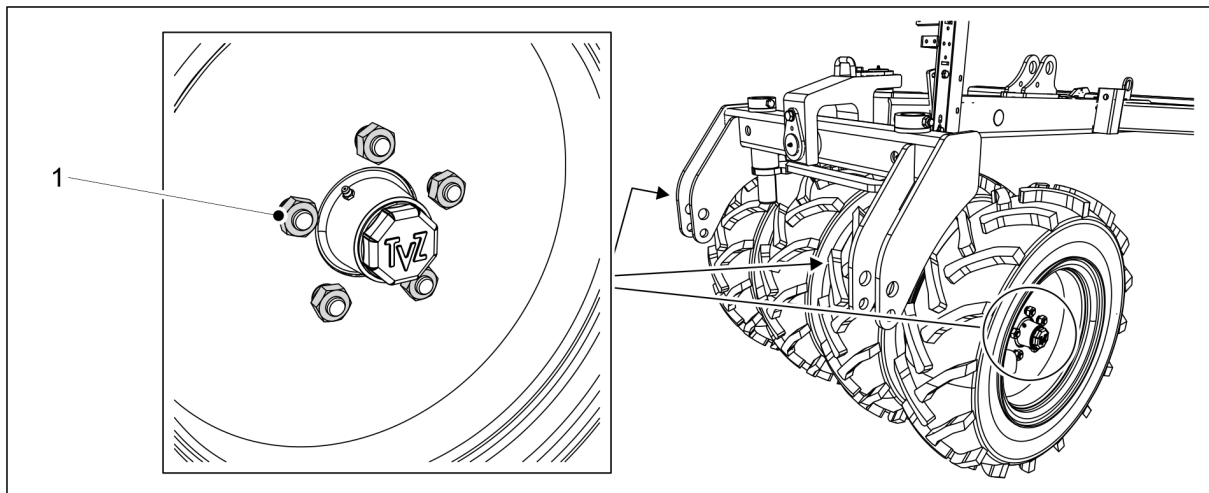

Figure. 7.1.2.3 - 219. Wheel bolts of the wheel packer

3. Check that all the 20 wheel bolts (M18) (1) of the wheel packer are tight.
 - Tighten the bolts, if needed.
4. Replace the wheel packer bar and lock the bar with cotters.

7.1.2.4 Checking the tightness of coultter bolts

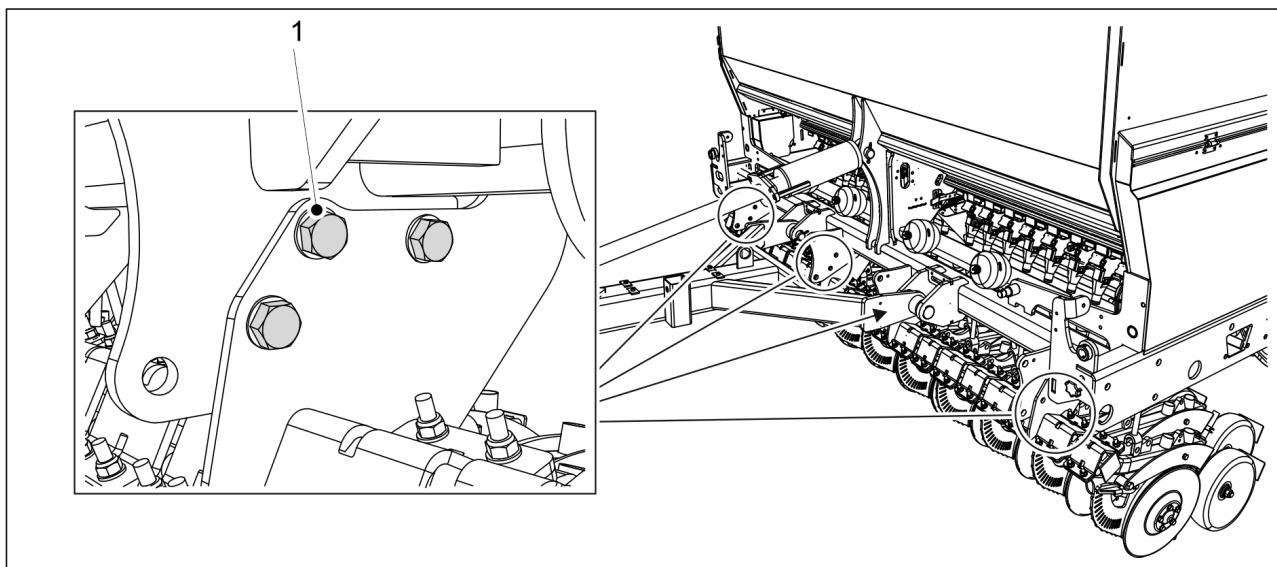

Figure. 7.1.2.4 - 220. Coultter shank bolts

1. Check that the coultter shank M20 bolts (1) are tight.
 - There are 12 coultter shank bolts on the FORTE 300 EVO and 18 on the FORTE 400 EVO.
If needed, tighten the bolts to torque 300 Nm.

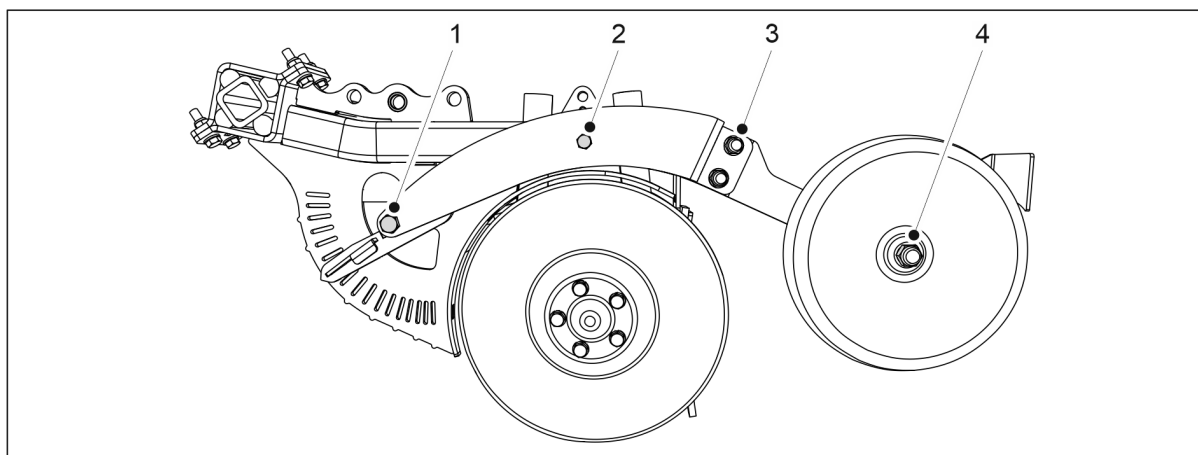

Figure. 7.1.2.4 - 221. Bolts of the coultter covering wheel and depth adjustment

2. Check that the two bolts (M16) (3) on all the coultter covering wheels are tight.
 - Tighten the bolts, if needed.
3. Check that the coultter depth adjustment bolts (M16) (1) and M12 (2) are tight.
 - Tighten the bolts, if needed. The torque to be used on the M12 bolt (2) is 120 Nm.

7.1.2.5 Checking the tightness of the working platform bolts

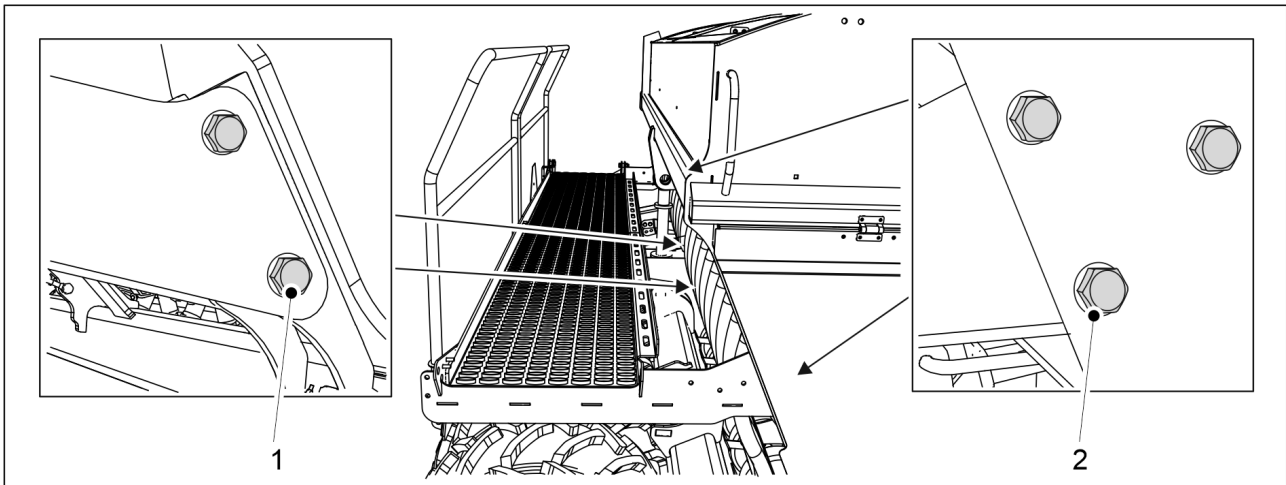

Figure. 7.1.2.5 - 222. Working platform bolts

1. Check that the 6 M12 bolts (2) of the working platform are tight.
 - Tighten the bolts, if needed.
2. Check that the 4 M16 bolts (1) near the lifting cylinder are tight.
 - Tighten the bolts, if needed.

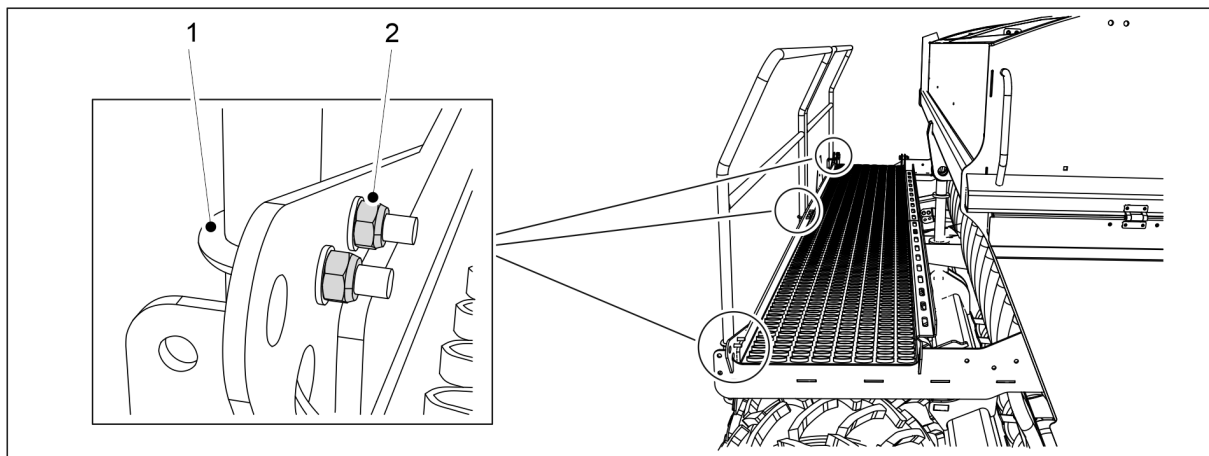

Figure. 7.1.2.5 - 223. Working platform U-bolts

3. Check that the 8 M8 nuts (2) of the U-bolts (1) are tight.
 - Tighten the bolts, if needed.

7.1.2.6 Checking the tightness of the towing eye bolts

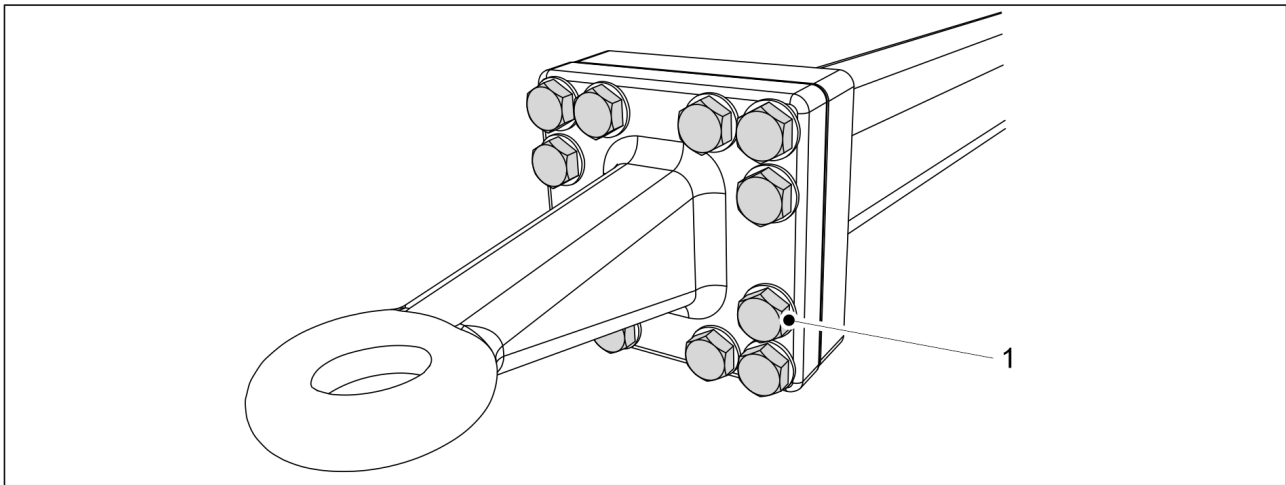

Figure. 7.1.2.6 - 224. Towing eye bolts

1. Check that the 12 bolts (1) of the towing eye are tight.
 - If needed, tighten the bolts to torque 400 Nm.

7.1.3 Checking tyre pressure

- The correct rear tyre (250/80-18) pressure is 1.5 bar.
The correct pressure of the wheel packer's tyres is 1.5 bar.

7.1.4 Checking the bearing clearance of the wheel packer hubs

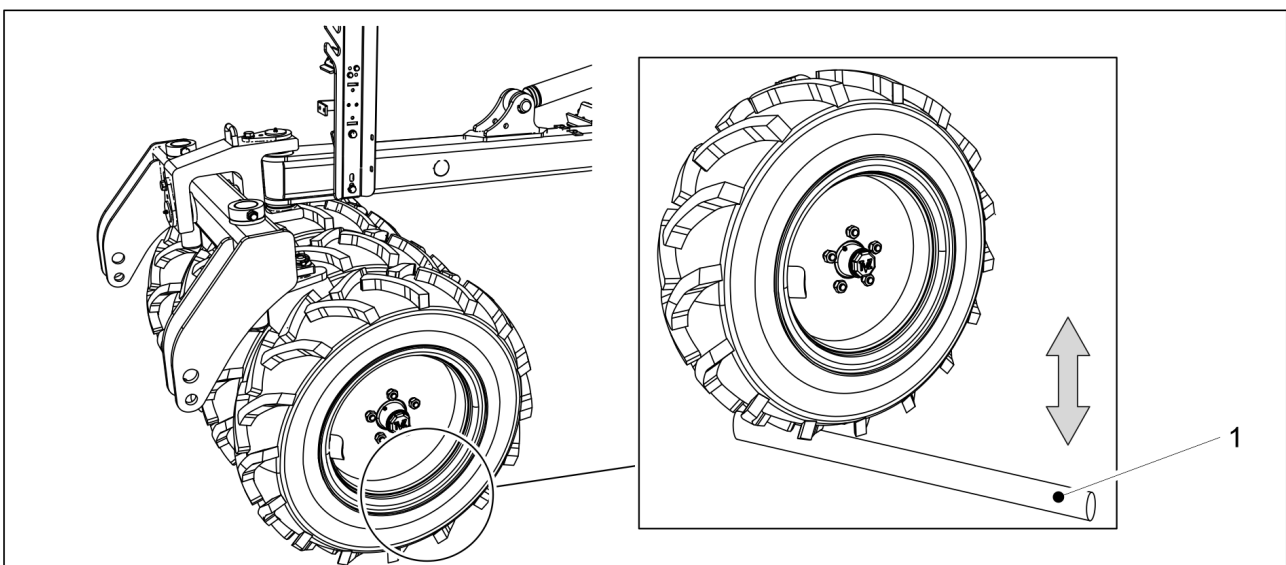

Figure. 7.1.4 - 225. Checking the bearing clearance of the wheel packer hubs

1. Insert a bar (1) between the wheel and the platform.
2. Move the bar to ensure that there is no looseness in the wheel bearing.

- If there is looseness in the wheel hub bearing, tighten the bearing in accordance with [7.6.1 Tightening the bearing](#).

7.1.5 Checking the tightness of the transmission chains

7.1.5.1 Checking chain tightness, fertiliser and seed transmission

1. Lift the transmission cover on the left side of the machine.

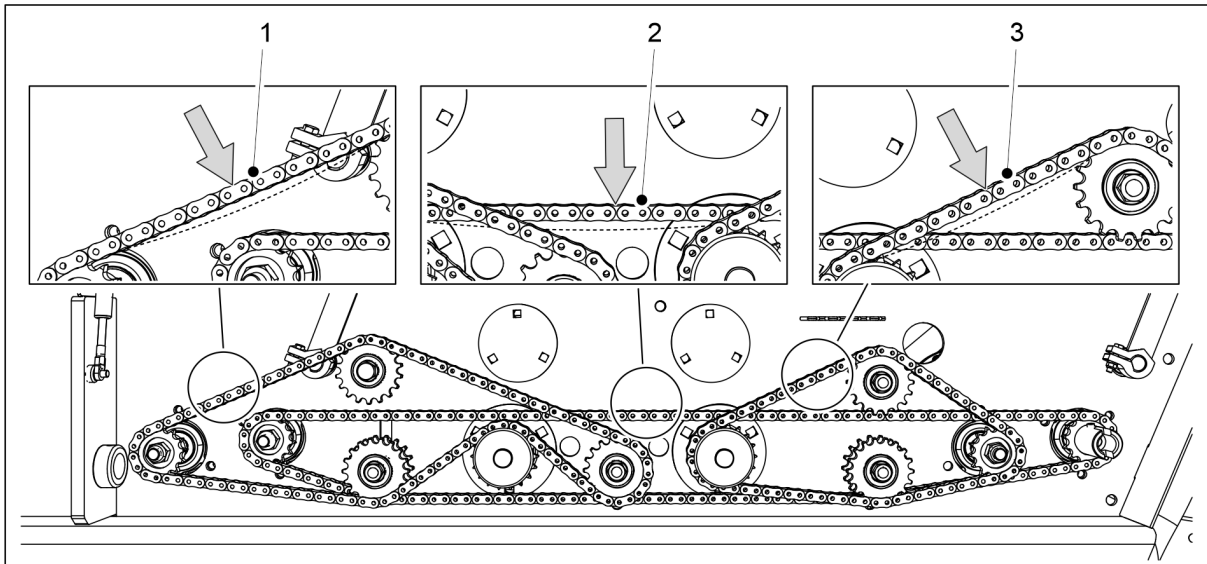

Figure. 7.1.5.1 - 226. Checking chain tightness, fertiliser and seed transmission

2. Check the deflection of the fertiliser hopper chain (1) and the seed hopper chain (3) by pressing the chain down with your finger.
 - The maximum allowed deflection (A) is 10 mm. If needed, tighten the chains in accordance with section [7.5.1 Tightening the chains, fertiliser and seed transmission](#).
3. Check the deflection of the gearbox chain (2) by pressing the chain down with your finger.
 - The maximum allowed chain deflection along the whole length is 15-20 mm. A chain that is too loose can rub against the bearings of the feeder shafts. If needed, tighten the chains in accordance with section [7.5.1 Tightening the chains, fertiliser and seed transmission](#).
4. Lower the transmission cover.

7.1.5.2 Checking chain tightness, small seed transmission

1. Lift the transmission cover on the right side of the machine.

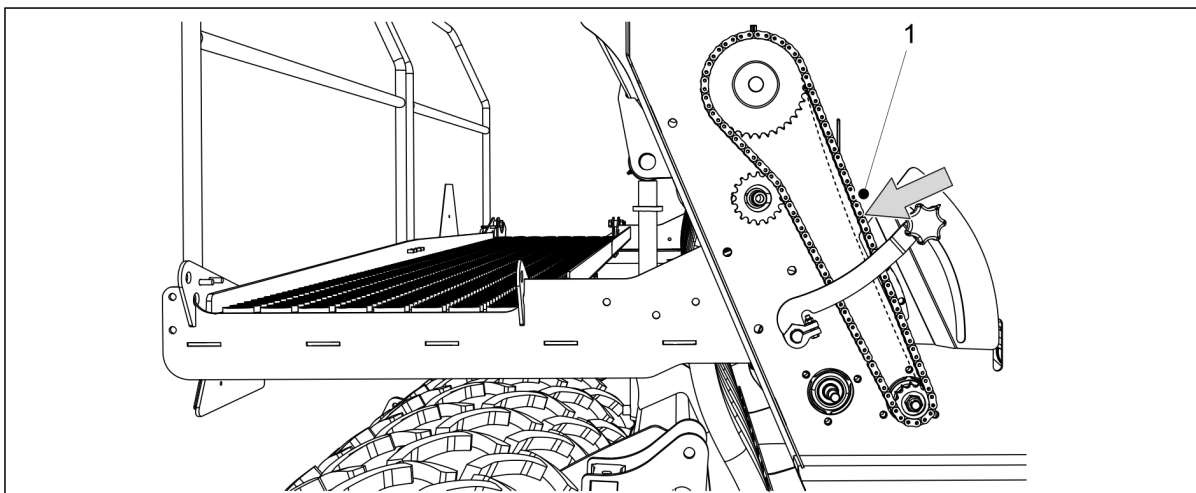

Figure. 7.1.5.2 - 227. Checking chain tightness, small seed transmission

2. Check the deflection of the transmission chain (1) by pressing the chain down with your finger.
 - The maximum allowed deflection (A) is 10 mm. If needed, tighten the chains in accordance with section [7.5.2 Chain tightening, small seed transmission](#).
3. Lower the transmission cover.

7.1.5.3 Checking chain tightness, fertiliser dispersing axle transmission

1. Lift the transmission cover on the left side of the machine.

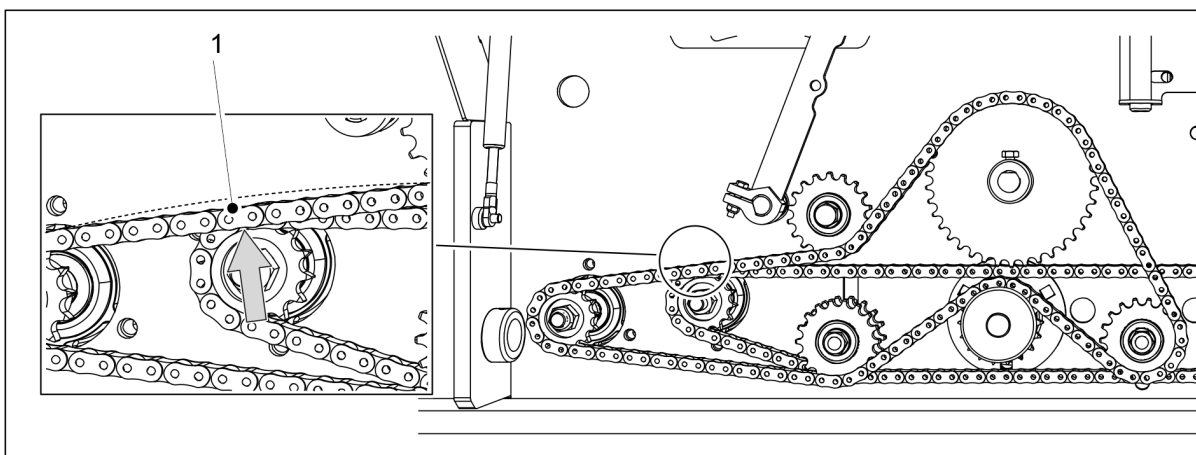

Figure. 7.1.5.3 - 228. Checking chain tightness, fertiliser dispersing axle transmission

2. Check the deflection of the transmission chain (1) by lifting the chain with your finger.
 - The maximum allowed deflection (A) is 10 mm. If needed, tighten the chains in accordance with section [7.5.3 Chain tightening, fertiliser dispersing axle transmission](#).
3. Lower the transmission cover.

7.1.5.4 Checking chain tightness, seed dispersing axle transmission

1. Lift the transmission cover on the left side of the machine.

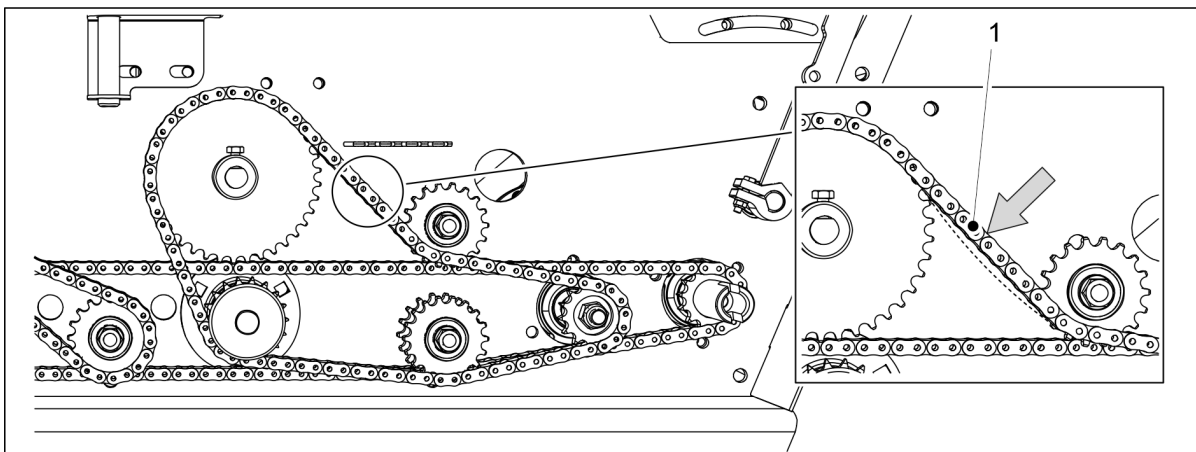

Figure. 7.1.5.4 - 229. Checking chain tightness, seed dispersing axle transmission

2. Check the deflection of the transmission chain (1) by pressing the chain down with your finger.
 - The maximum allowed deflection (A) is 10 mm. If needed, tighten the chains in accordance with section [7.5.4 Chain tightening, seed dispersing axle transmission](#).
3. Lower the transmission cover.

7.1.6 Checking the tightness of the wheel drive chain

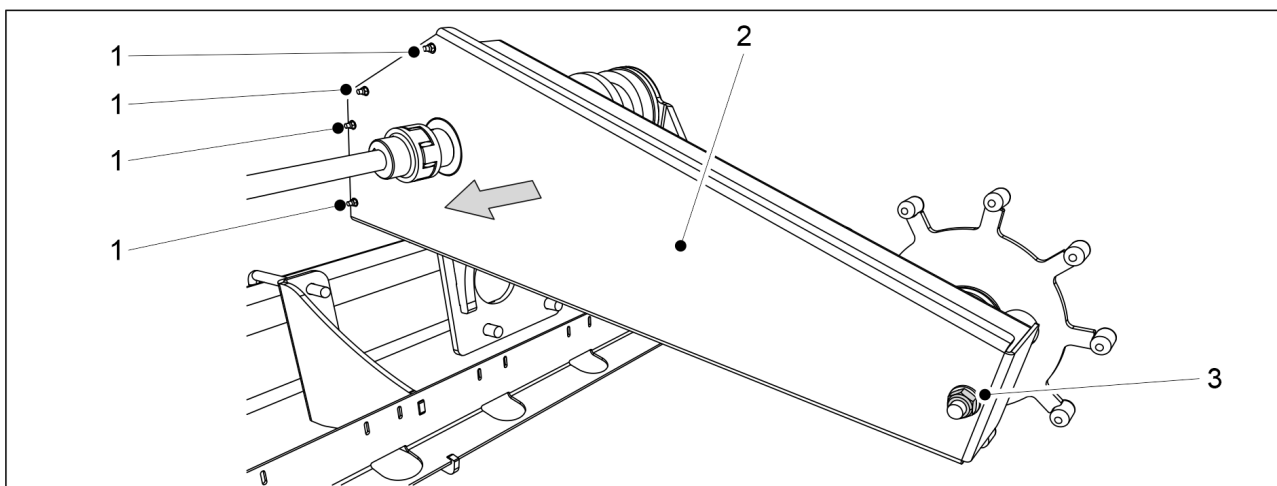

Figure. 7.1.6 - 230. Cover of the wheel drive housing

1. Remove the 4 cover bolts (1) from the front end of the wheel drive housing and the cover mounting nut (3) from the rear end of the housing.
2. Remove the cover (2).

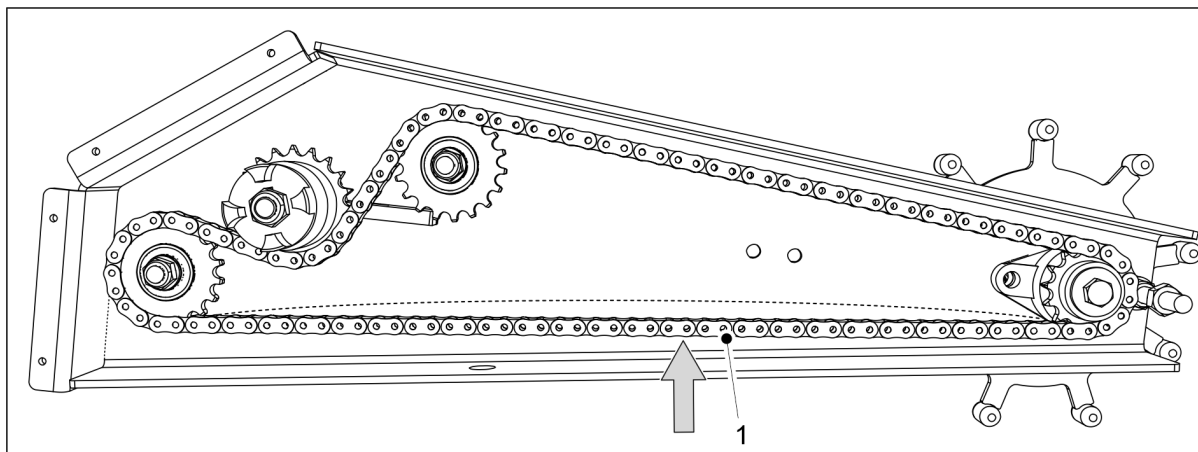

Figure. 7.1.6 - 231. Wheel drive chain

3. Check the chain (1) deflection.
 - The maximum allowed deflection (A) is 10 mm. If needed, adjust the chain tension in accordance with section [7.7.1 Tightening the wheel drive chain](#).
4. Replace the cover.
5. Attach the bolt at the front end of the housing and the mounting that at the rear end of the housing.
 - Always use new locknuts to install.

7.1.7 Inspecting the wheel drive clutch

- The clutch should be inspected once per year / seeding season.

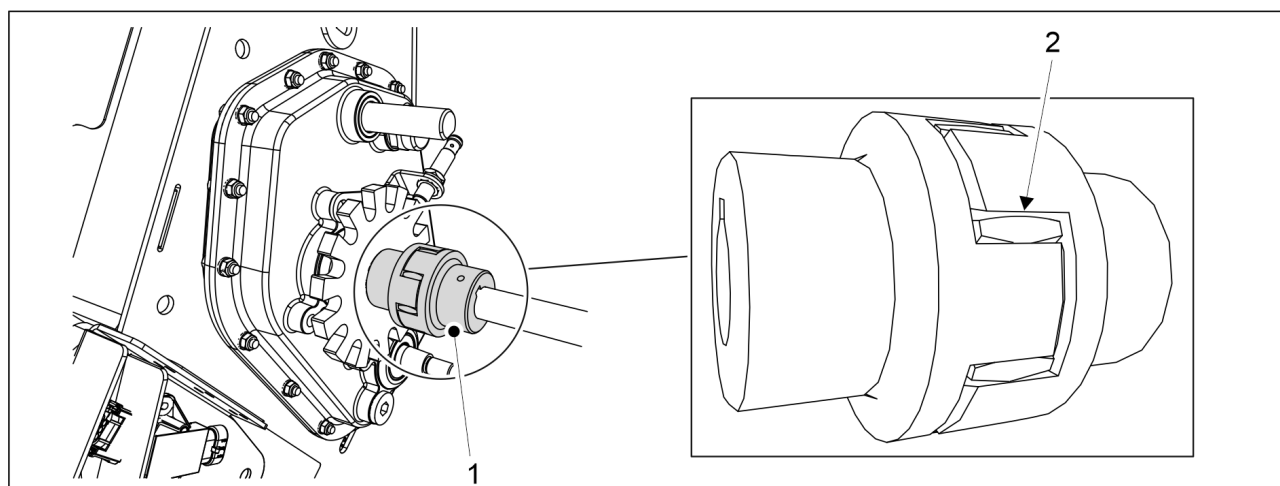

Figure. 7.1.7 - 232. Inspecting the clutch

1. Check the clearance of the flexible coupling element of the clutch (1).
 - Use a feeler gauge to measure between the hub and the flexible coupling element (2).
If the clearance is 3 mm or more, replace the flexible coupling element in accordance with section [7.7.2 Replacing the wheel drive clutch](#).

7.1.8 Inspecting the wheel drive clutch

1. Lower the machine to its working position.

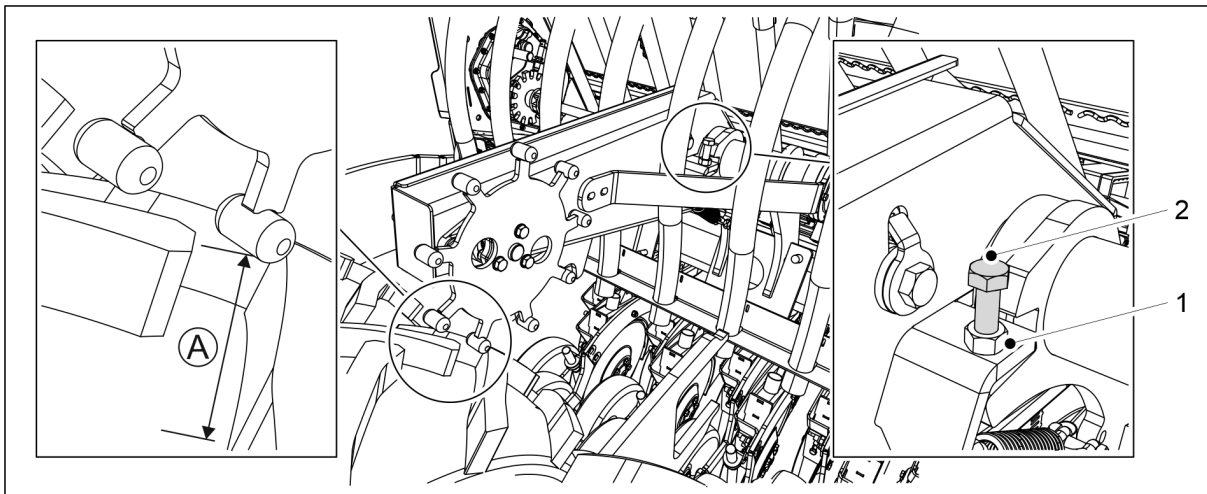

Figure. 7.1.8 - 233. Inspecting the wheel drive clutch

2. Inspect the wheel drive clearance (A).
 - Measure the clearance between the wheel drive head and lower surface of the transport wheel. The clearance should be 3-5 mm.
3. First loosen the locking nut (1) to adjust the clearance.
 - If the clearance is less than 3 mm, raise the drive wheel by turning the bolt (2) clockwise.
If the clearance is more than 5 mm, lower the drive wheel by turning the bolt (2) counterclockwise.
4. After adjusting, tighten the locking nut.

7.1.9 Checking the condition of hydraulics

1. Check the tightness of the hydraulic system.
2. If necessary, tighten the connections.
3. Make sure that the hoses are intact and have no leaks.
 - If needed, contact maintenance.

7.1.10 Checking the condition of electric wires

1. Ensure that the insulation of the wires is not worn and that the wires are visible.
2. Ensure that the insulation of the wires have not melted and have no signs of heating or burning.
 - If needed, repair by using, for example, tape as additional insulation.
 - If a wire or leads of the wire are cut, contact maintenance.

7.1.11 Inspecting the towing eye

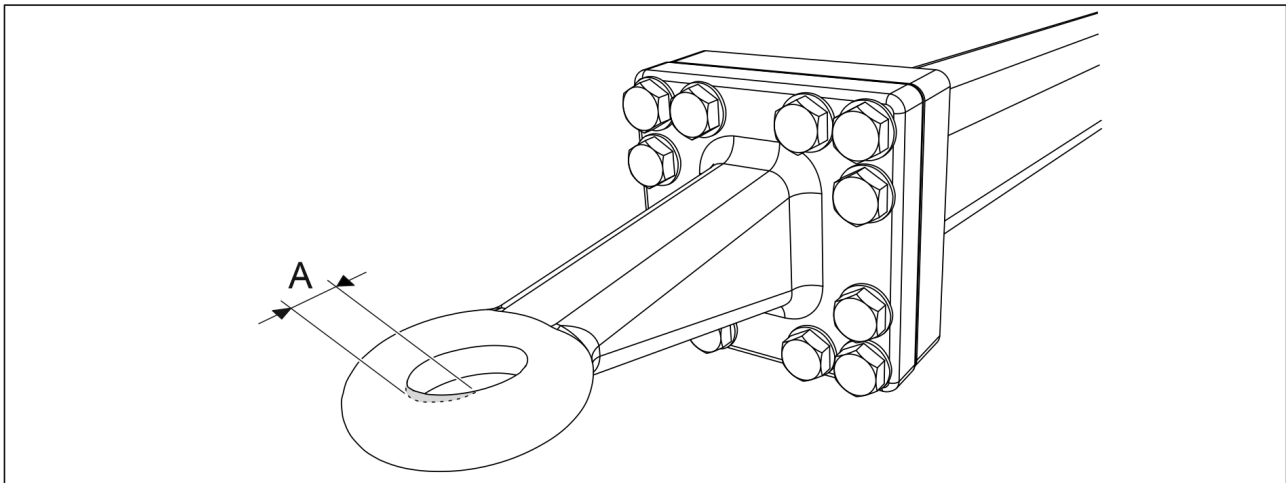

Figure. 7.1.11 - 234. Wear in the towing eye

1. Check that the towing eye is not too worn.
 - The maximum wear (A) is 2.5 mm. The maximum size for the opening is 52.5 mm.
2. Check that there are no fractures in the towing eye.
 - If necessary, replace the towing eye in accordance with section [7.8.1 Replacing the towing eye](#).

7.1.12 Checking the gearbox oil level

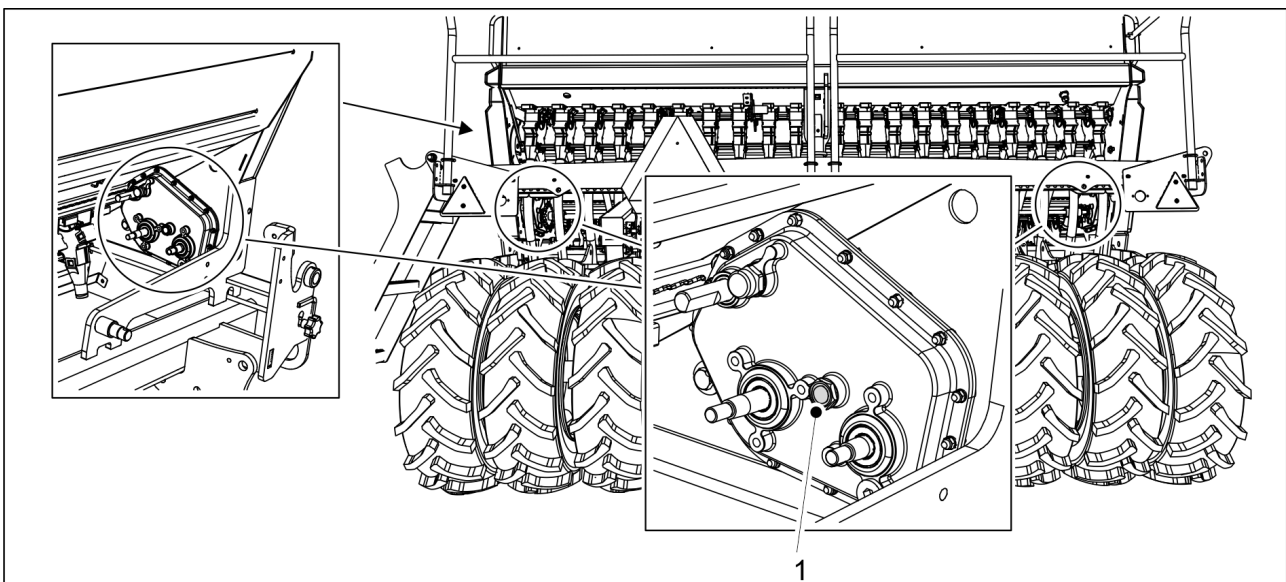

Figure. 7.1.12 - 235. Gearbox oil level

1. Check the gearbox oil level.

- The oil level is correct when it is visible in the inspection window (1). If needed, add oil.
The oil must be changed at least every five years to remove condensed water from the gearbox.
The correct oil volume is 0.8 litres. Use ISO VG32 grade hydraulic oil.

7.1.13 Inspecting the coultter discs

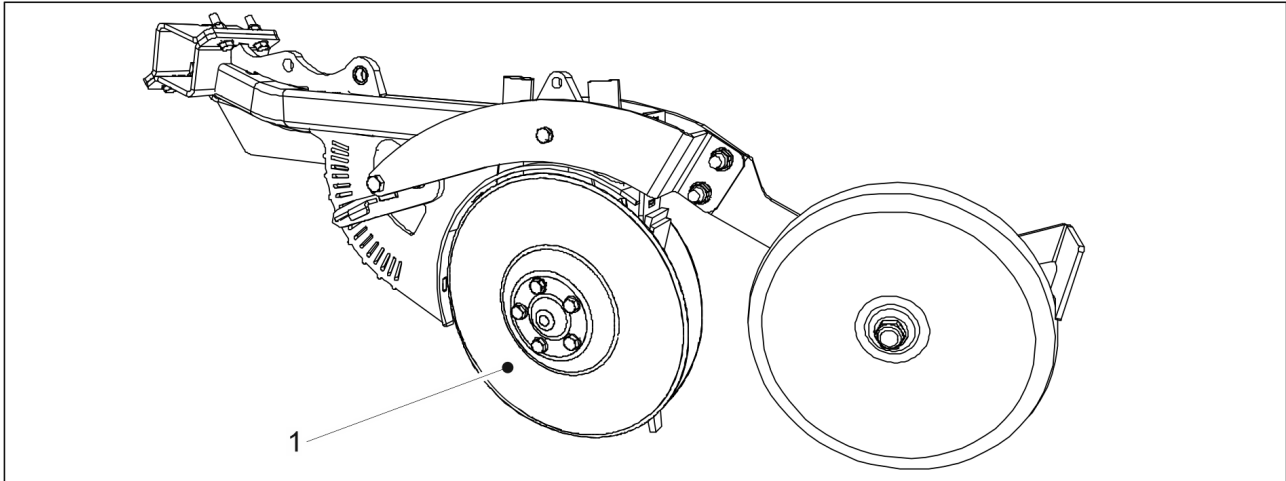

Figure. 7.1.13 - 236. Coultter discs

1. Check that the movement of discs (1) in relation to one another is slightly restrained and no clearance is felt in the bearing when turning a disc from the rear edge.
 - If the discs move easily in relation to one another or the bearing clearance is excessive, adjust the pretension with a shim.
If a disc does not rotate, clean the discs, if necessary, in accordance with section [7.3.4 Cleaning the coultter discs](#). If the disc still does not rotate, replace the disc, if needed, in accordance with section [7.9.2 Replacing a coultter disc](#) or replace the bearing in accordance with section [7.9.3 Replacing a coultter bearing](#).
2. Measure the diameter of the disc.
 - The disc should be round, with a minimum diameter of 350 mm. If the diameter is less than 350 mm, replace the disc, if necessary, in accordance with section [7.9.2 Replacing a coultter disc](#).

7.1.14 Checking the functioning of the adjusting of the fertiliser target rate

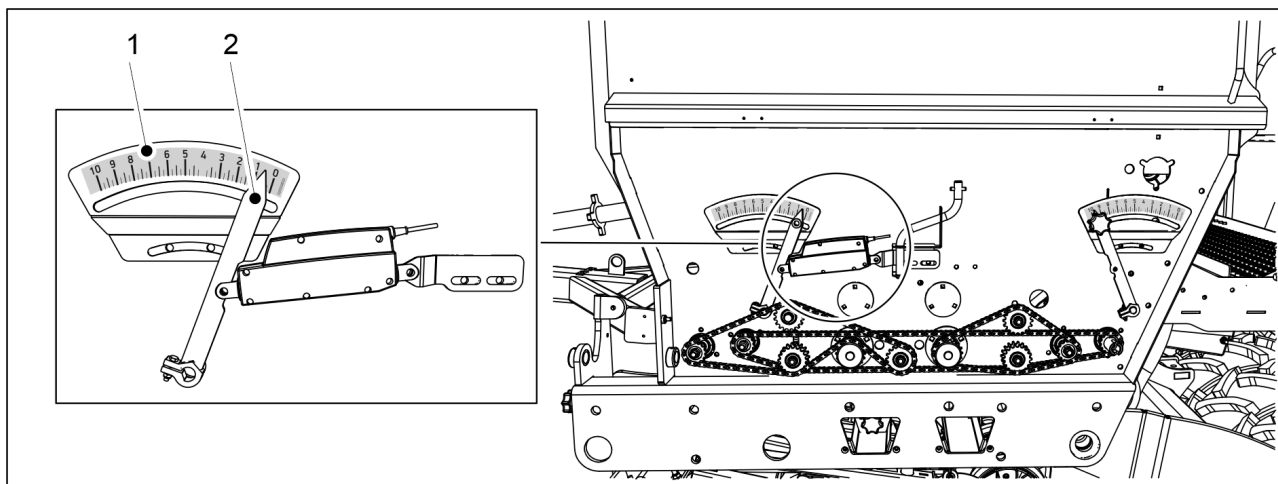

Figure. 7.1.14 - 237. Checking the functioning of the adjusting of the fertiliser target rate

1. Enable the adjusting of the fertiliser target rate and ensure that the dial (2) moves in the fertiliser feeding quantity scale (1).

7.1.15 Checking the brake system

The inspections to be performed on the seed drill brake system (if installed) are shown in the following table.

Table. 7.1.15 - 25. Inspections to be performed on the brake system

	Daily	Every 500 hectares or once per operating season ¹⁾
<u>7.1.15.2 Draining water from the pneumatic tank</u>	X	
<u>7.1.15.1 Checking brake pads</u>		X
<u>7.1.15.3 Checking the oil level in the pneumatic-hydraulic converter</u>		X
<u>7.1.15.4 Cleaning palm coupling filters</u>		X

¹⁾ Inspections that are to be performed once an operating season should be done in the spring, when the machine is being started up for the first time after being stored for the winter.

7.1.15.1 Checking brake pads



DANGER

The brake pads are located in the outermost transport wheels on both sides of the seed drill.

Ensure that the brake drum and other brake parts have cooled off before performing any maintenance or repairs. Burn hazard.

1. Check the brake pads for any wear.
 - Replace the brake pads if the thickness of the friction surface is less than 1.5 mm.

7.1.15.2 Draining water from the pneumatic tank

- These instructions only apply to seed drills equipped with a pneumatic brake system. The tank must be drained on a daily basis.

The pneumatic tank (1) is located on the drawbar.

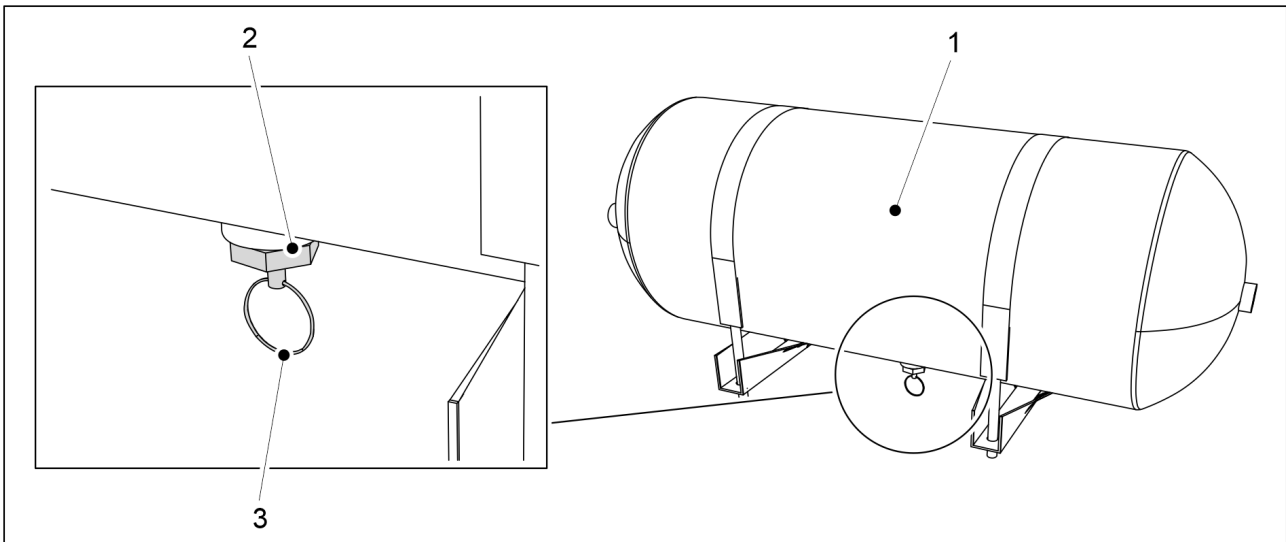

Figure. 7.1.15.2 - 238. Draining water from the pneumatic tank

1. Pull the pneumatic tank (1) drain valve (2) cord (3) down.
2. Keep the valve open until the air coming out of the valve is dry.
3. Release the cord.
 - The valve will close automatically.

7.1.15.3 Checking the oil level in the pneumatic-hydraulic converter

- These instructions only apply to seed drills equipped with a pneumatic brake system.

The pneumatic-hydraulic converter (1) is located on the drawbar.

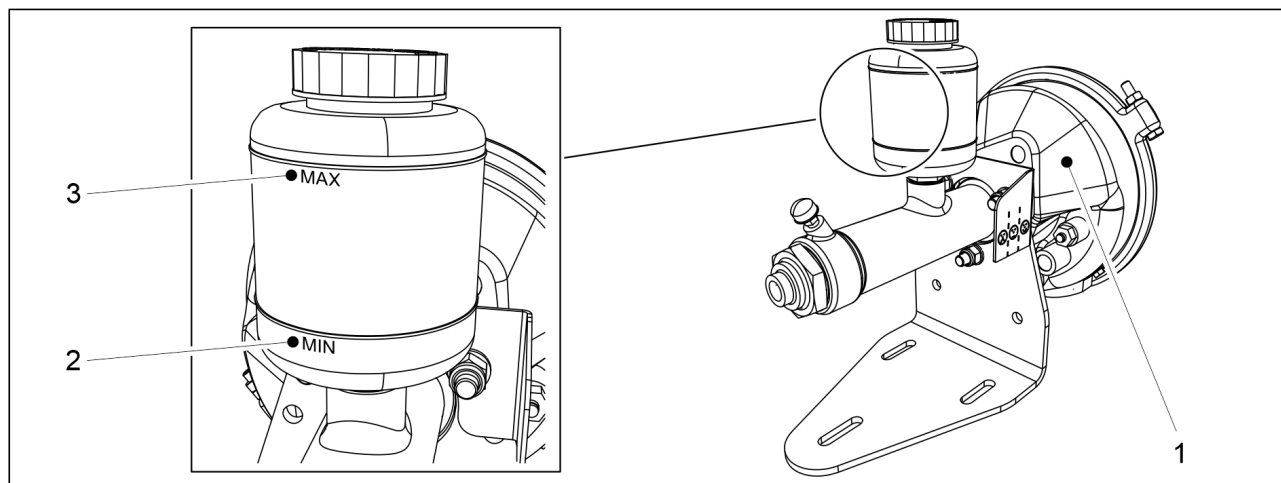

Figure. 7.1.15.3 - 239. Checking the oil level in the pneumatic-hydraulic converter

1. Ensure that the oil level in the oil tank is between the MIN (2) and MAX (3) markings.
2. If needed, add oil.
 - Use a mineral oil intended for hydraulic systems.

7.1.15.4 Cleaning palm coupling filters



DANGER

Exercise extreme caution when connecting or disconnecting pneumatic hose couplings. A pneumatic hose can jerk suddenly. Never direct compressed air on your skin.

- These instructions only apply to seed drills equipped with a pneumatic brake system. The filters are integrated in the palm couplings (2 pcs) of the seed drill pneumatic brake system.

1. Remove the filter cartridges from the palm couplings.
2. Clean the filter cartridges with a cleaning agent.
3. Dry the filter cartridges with compressed air.
4. Replace the filter cartridges in the palm couplings.

7.2 Lubrication

- After the commissioning of the machine, all lubrication points should be lubricated after the first 10 hectares.

The disc coulters are equipped with self-lubricating bearings, which do not need to be lubricated.

When lubricating, make sure that the grease nipple is open. Lubricate the point until grease flows out of the joint. Usually, 1- 2 squeezes of a grease gun is enough for the grease nipples. Wipe off excess grease.

Use lithium-based lubricating grease for lubrication. The chains are lubricated with high-quality motor oil.

The use of viscous, long-fibre grease and grease containing solid lubricant particles (molybdenum sulphide and graphite) is prohibited.

7.2.1 Quick instructions, lubrication

Table. 7.2.1 - 26. Lubrication points

	1) Every 50 hectares	2) Every 500 hectares or once per operating season	Number of lubricating nipples in the machine (pcs)
<u>7.2.2 Lubricating the transmission chains</u>		X	
<u>7.2.3.1 Lubricating the wheel drive chain</u>		X	
<u>7.2.3.2 Lubricating wheel axle bearings</u>		X	3
<u>7.2.4 Lubricating the rear axle mounting</u>		X	2
<u>7.2.5 Lubricating the wheel axle bearings</u>		X	6
<u>7.2.6 Lubricating the lifting cylinder</u>		X	FORTE 300 EVO: 2 FORTE 400 EVO: 6
<u>7.2.7 Lubricating the towing eye</u>		X	
<u>7.2.8 Lubricating the middle marker cylinders</u>		X	4
<u>7.2.9 Lubricating the rear marker cylinders</u>		X	4
<u>7.2.10 Lubricating the wheel packer pins and wheel hubs.</u>	X	X	6 (in pins) 4 (in wheels)
<u>7.2.11 Lubricating the cylinders of the front levelling board</u>		X	2
<u>7.2.12 Lubricating the front harrow cylinders</u>		X	2
<u>7.2.13 Lubricating the front disc cultivator cylinders</u>		X	2
<u>7.2.14 Lubricating the drawbar cylinder</u>		X	2
<u>7.2.15 Lubricating the turnbuckle</u>		X	4
<u>7.2.16 Lubricating the parking brake lever shafts</u>		X	2

<u>7.2.17 Lubricating the parking brake crank</u>		X	1
<u>7.2.18 Lubricating the transport wheels centre axle lift cylinder</u>		x	2

7.2.2 Lubricating the transmission chains

7.2.2.1 Chain lubrication, fertiliser- and seed hopper transmission

1. Lift the transmission cover on the left side of the machine.

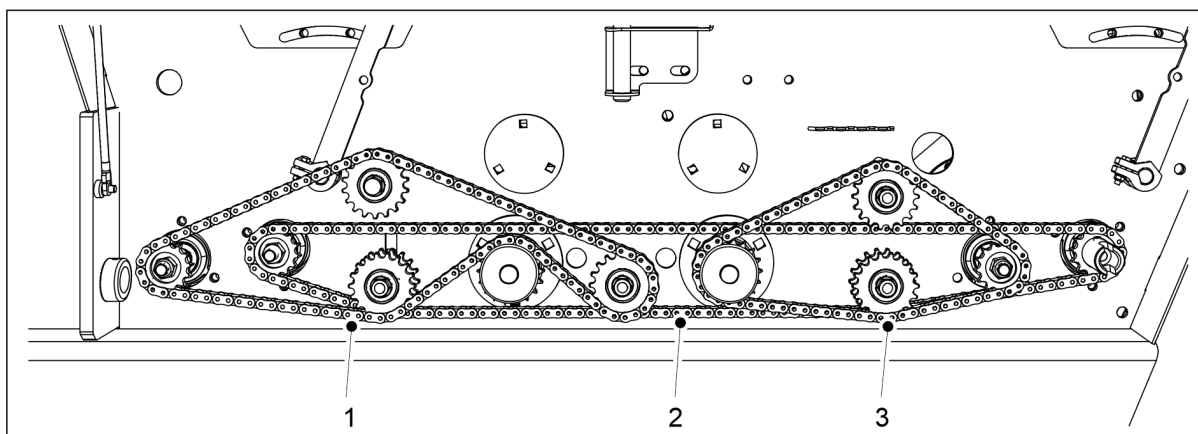

Figure. 7.2.2.1 - 240. Chain lubrication, fertiliser- and seed hopper transmission

2. Lubricate the fertiliser hopper chain (1), gearbox chain (2) and seed hopper chain (3).
 - Make sure that oil also flows between the chain discs and not only in the reel.
3. Lower the transmission cover.

7.2.2.2 Chain lubrication, small seed hopper transmission

1. Lift the transmission cover on the right side of the machine.

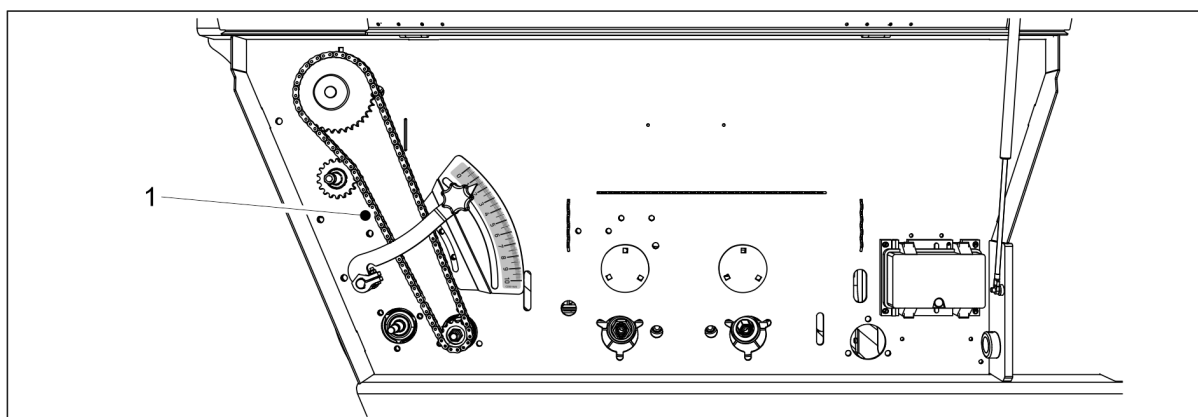

Figure. 7.2.2.2 - 241. Chain lubrication, small seed hopper transmission

2. Lubricate the chain (1).
 - Make sure that oil also flows between the chain discs and not only in the reel.
3. Lower the transmission cover.

7.2.3 Lubricating the wheel drive

7.2.3.1 Lubricating the wheel drive chain

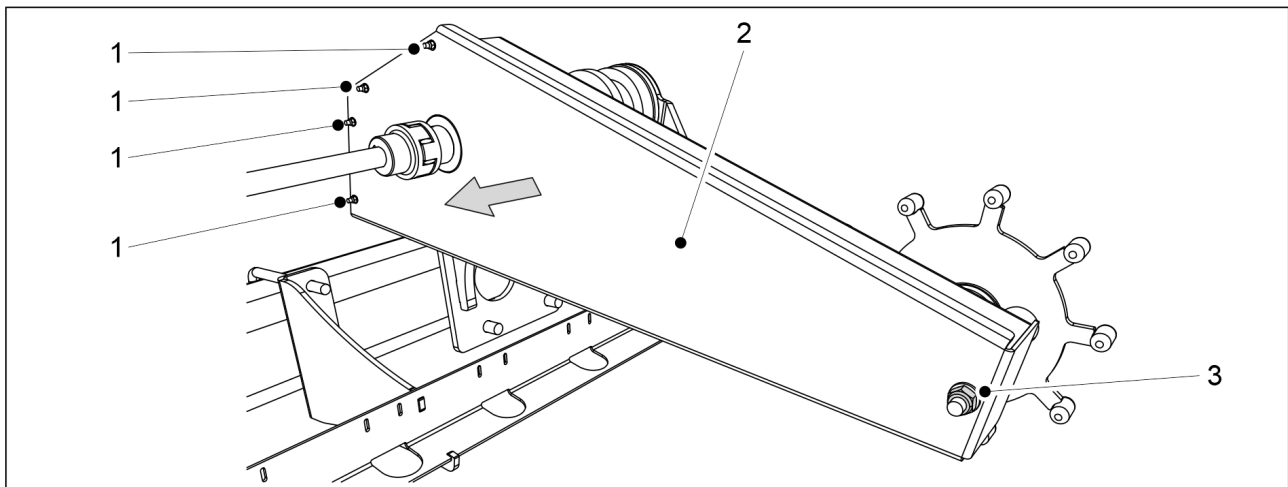

Figure. 7.2.3.1 - 242. Wheel drive chain

1. Remove the 4 cover bolts (1) from the front end of the wheel drive housing and the cover mounting nut (3) from the rear end of the housing.
2. Remove the cover (2).

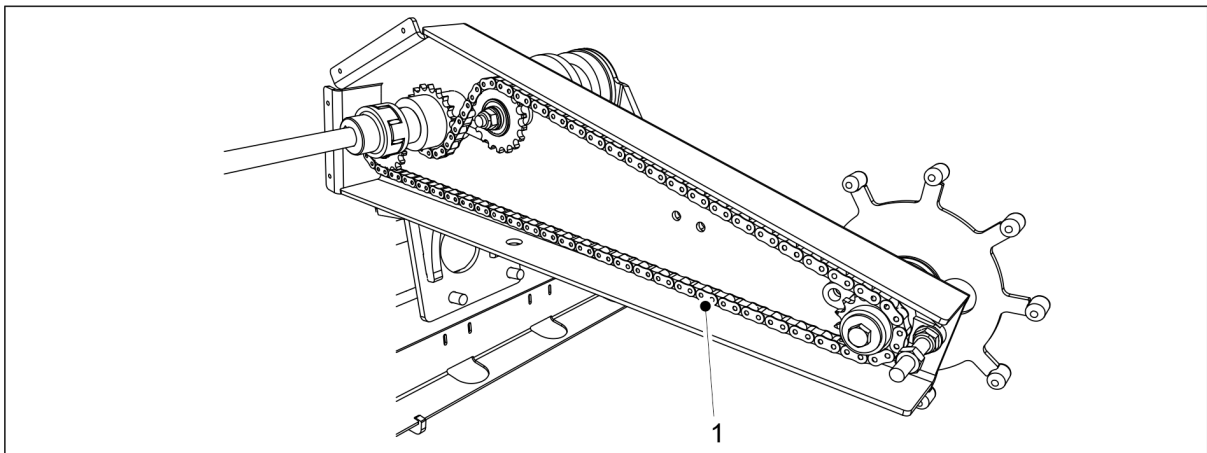

Figure. 7.2.3.1 - 243. Lubricating the wheel drive chain

3. Lubricate the chain (1).
 - Make sure that oil also flows between the chain discs and not only in the reel.
4. Replace the cover.
5. Attach the bolt at the front end of the housing and the mounting that at the rear end of the housing.
 - Always use new locknuts to fasten.

7.2.3.2 Lubricating wheel axle bearings

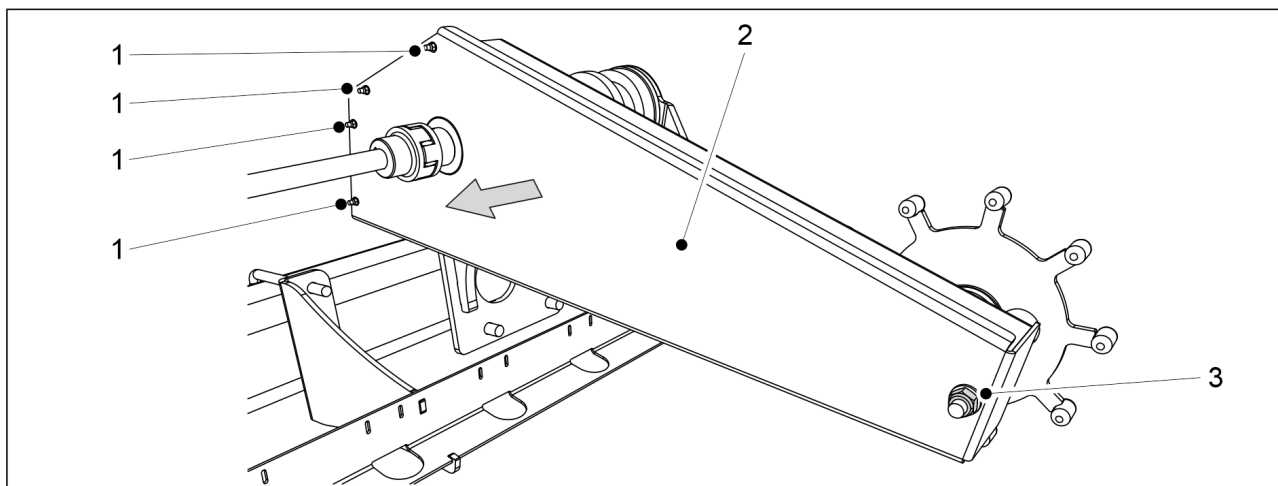

Figure. 7.2.3.2 - 244. Cover of the wheel drive housing

1. Remove the 4 cover bolts (1) from the front end of the wheel drive housing and the cover mounting nut (3) from the rear end of the housing.
2. Remove the cover (2).

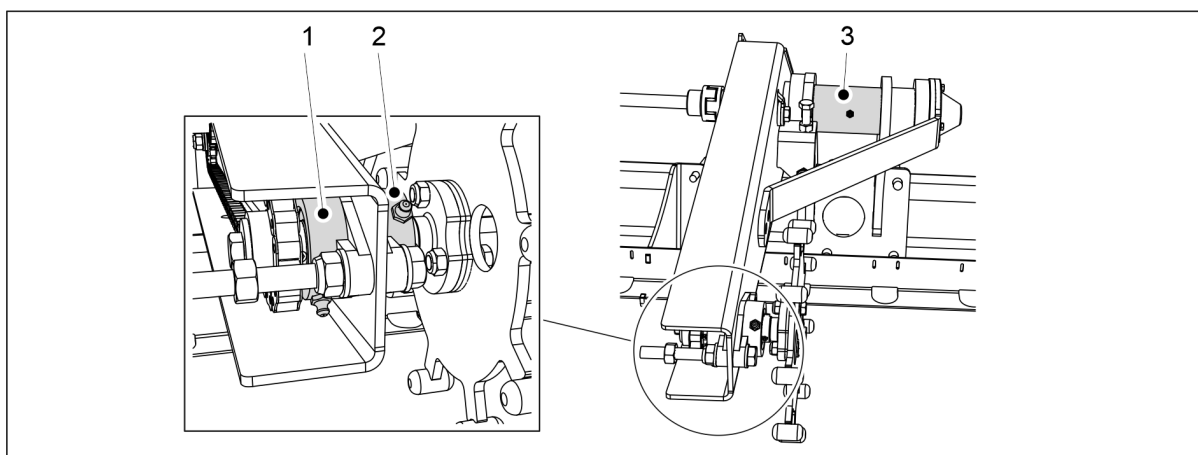

Figure. 7.2.3.2 - 245. Lubricating wheel axle bearings

3. Lubricate the 2 wheel drive bearings (1, 2) and the bearing of the wheel drive support (3) through the lubricating nipple.
 - Remove the extruding old grease from the bearing.
4. Replace the cover.
5. Attach the bolt at the front end of the housing and the mounting that at the rear end of the housing.
 - Use new locknuts to fasten.

7.2.4 Lubricating the rear axle mounting

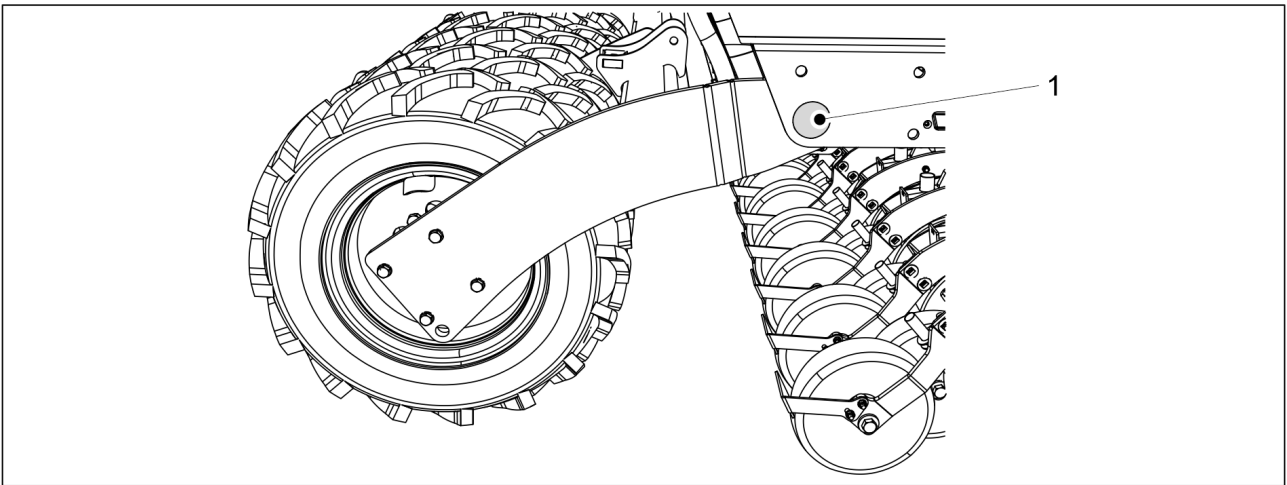

Figure. 7.2.4 - 246. Rear axle mounting

1. Lubricate the two link bushings of the rear axles mounting (1).
 - The link bushings are located in the rear corners of the hopper on both sides of the seed drill.

7.2.5 Lubricating the wheel axle bearings

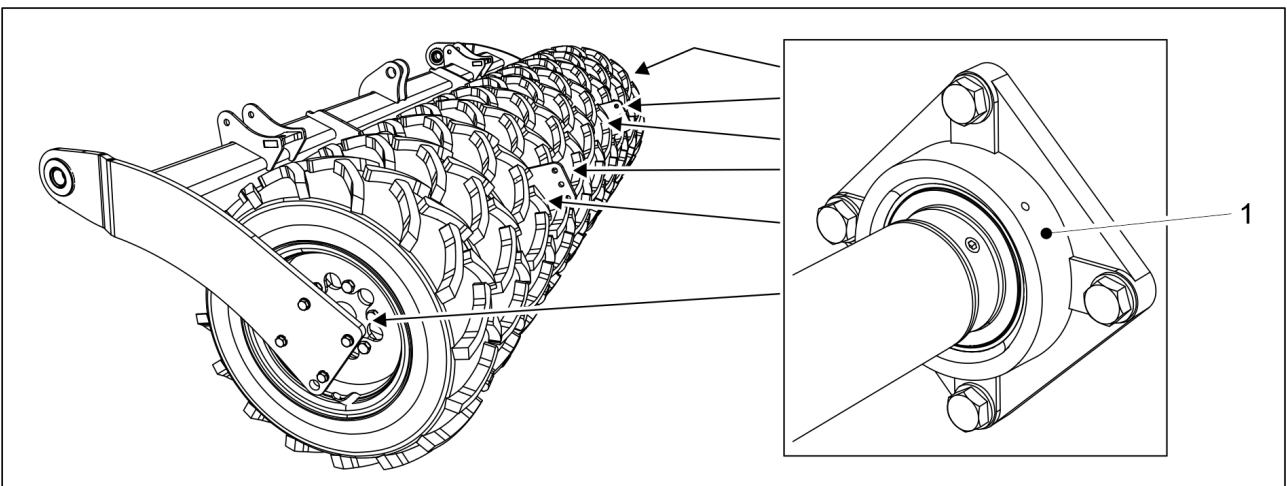

Figure. 7.2.5 - 247. Wheel axle bearings

1. Lubricate the six wheel axle bearings (1).

7.2.6 Lubricating the lifting cylinder

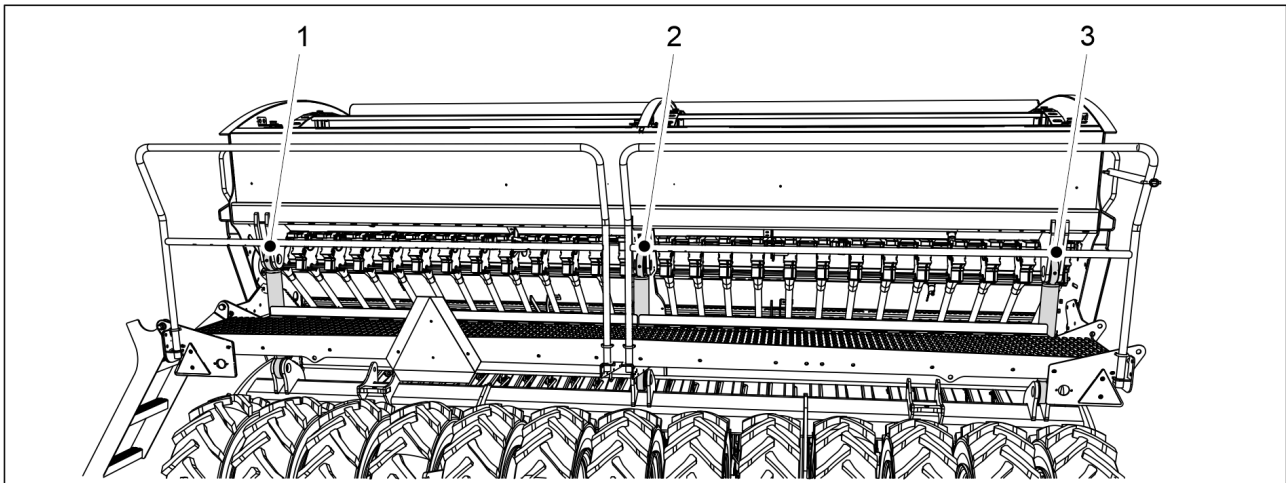

Figure. 7.2.6 - 248. Lifting cylinder

1. Lubricate the lifting cylinder(s).

- There is 1 lifting cylinder (2) on the FORTE 300 EVO and 3 lifting cylinders (1-3) on the FORTE 400 EVO.
There is a grease nipple at the top and bottom of the lifting cylinder.

7.2.7 Lubricating the towing eye

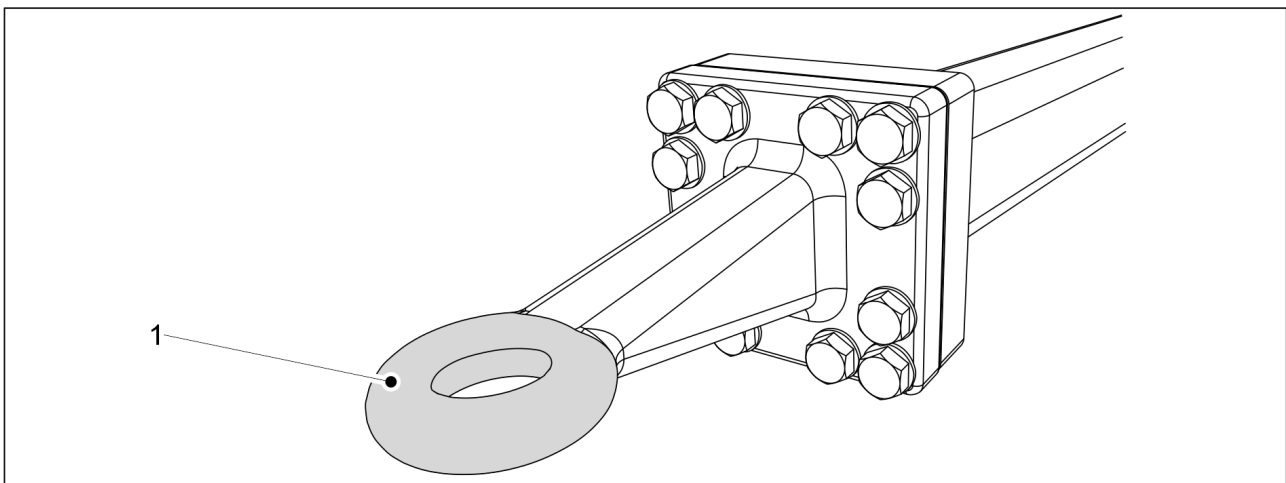

Figure. 7.2.7 - 249. Towing eye

1. Clean the towing eye (1) by wiping it.
2. Apply lubricant on the towing eye.

7.2.8 Lubricating the middle marker cylinders

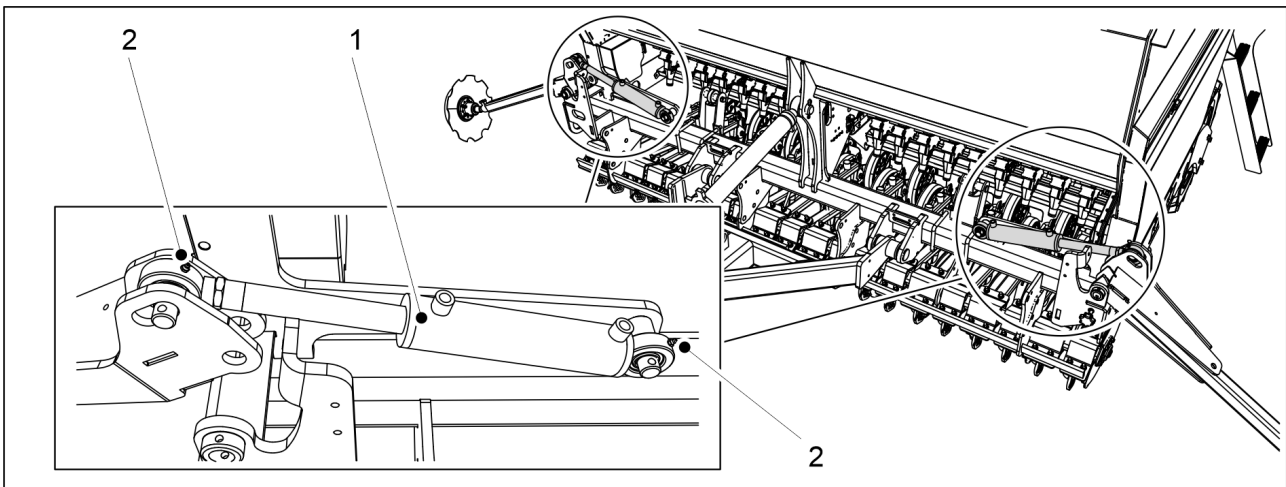

Figure. 7.2.8 - 250. Middle marker cylinders

1. Lubricate the 2 middle marker cylinders (1).
 - There is a grease nipple (2) at the top and bottom of the middle marker cylinder.

7.2.9 Lubricating the rear marker cylinders

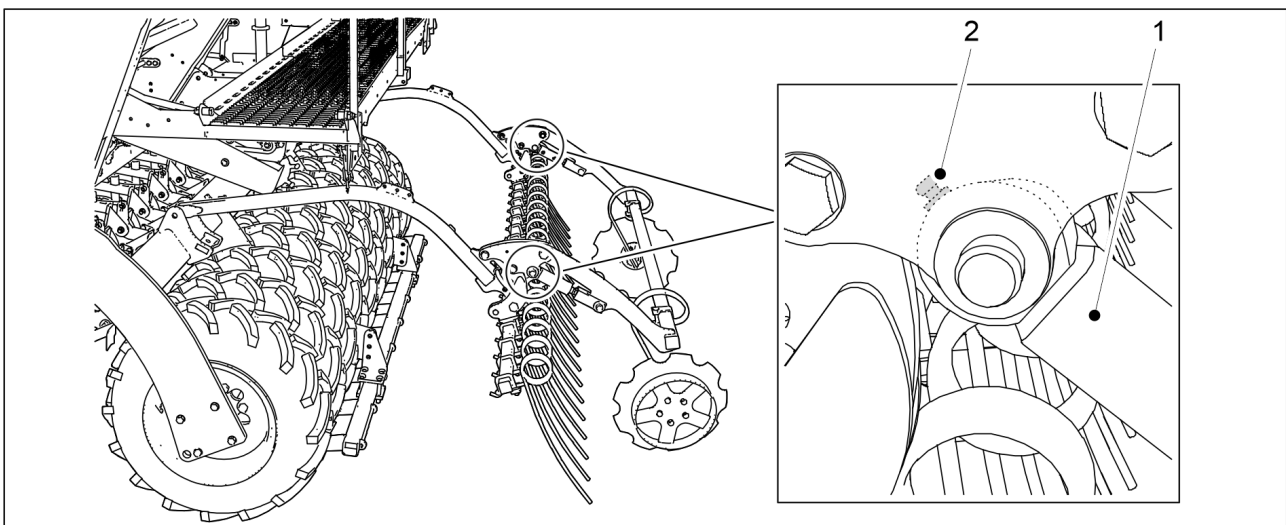

Figure. 7.2.9 - 251. Rear marker cylinders

1. Lubricate the 2 rear marker cylinders (1).
 - There is 1 grease nipple (2) in the bearing housing of both cylinders.

7.2.10 Lubricating the wheel packer pins and wheel hubs.

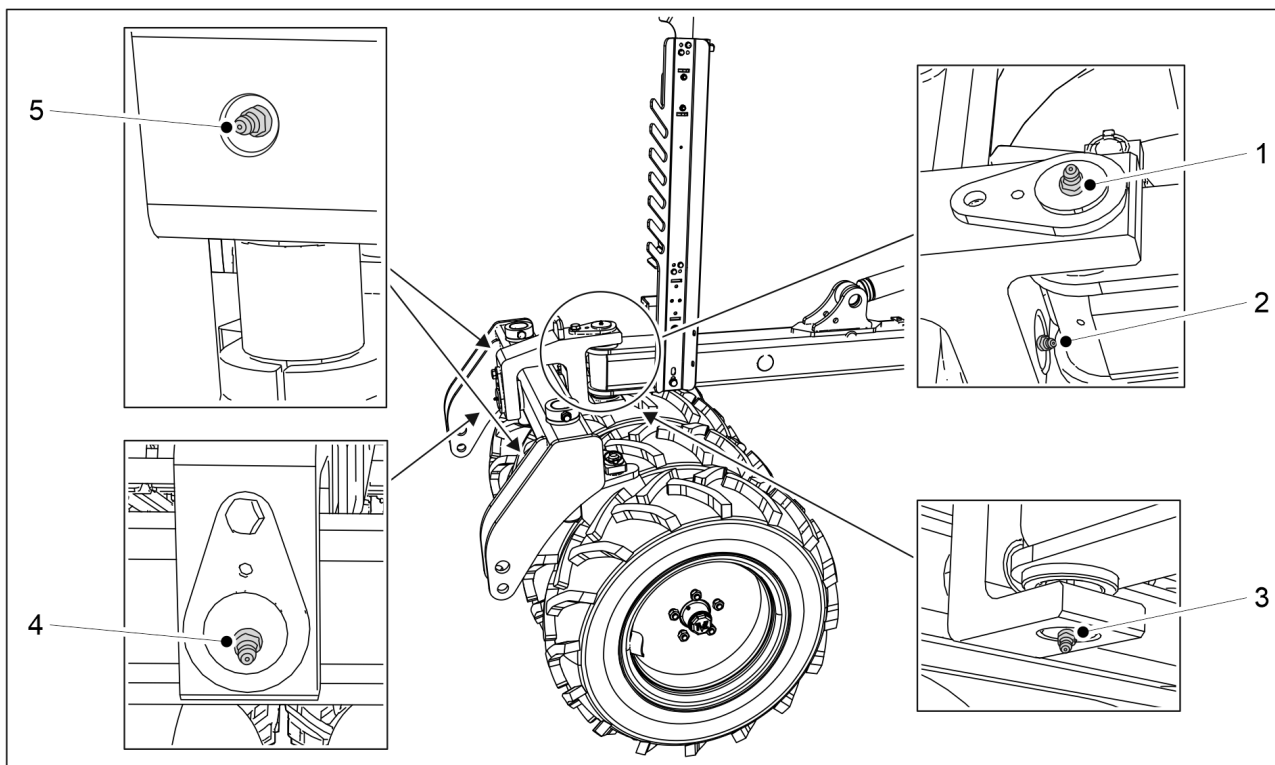

Figure. 7.2.10 - 252. Wheel packer pins

1. Lubricate the horizontal and vertical pin of the wheel packer.
 - The horizontal pin has 2 grease nipples (2,4). The vertical pin has 2 grease nipples (1,3).
2. Lubricate the two pins of the wheel packer bar.
 - There is one grease nipple (5) in both pins of the wheel packer bar.

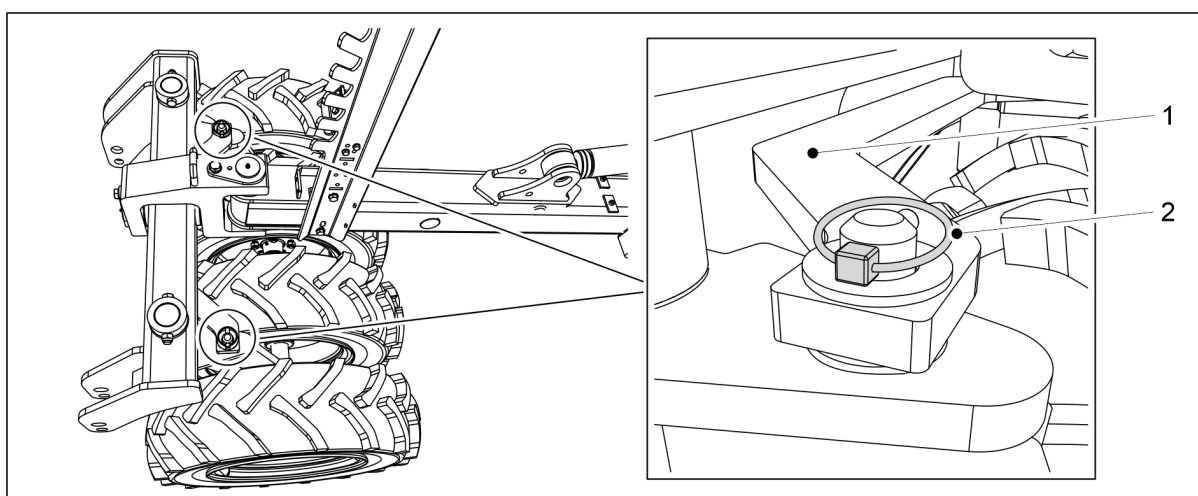

Figure. 7.2.10 - 253. Detaching the wheel packer bar

3. Detach the two cotters (2) of the wheel packer bar (1).
4. Detach the wheel packer bar by lifting it.

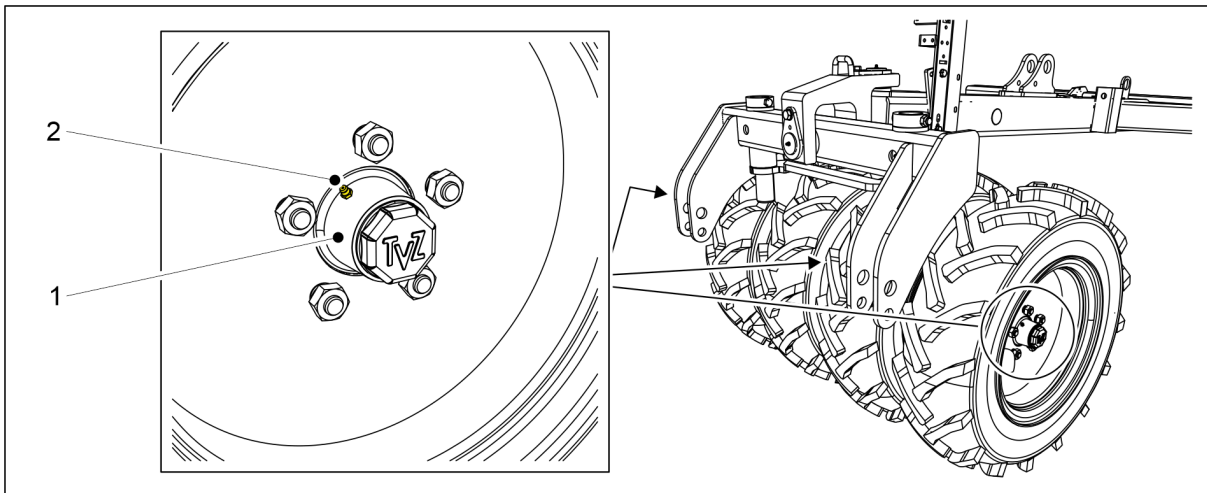

Figure. 7.2.10 - 254. Wheel hubs of the wheel packer

5. Lubricate the four wheel hubs (1).
 - The wheel hubs have a grease nipple (2).
6. Replace the wheel packer bar and lock the bar with cotters.

7.2.11 Lubricating the cylinders of the front levelling board

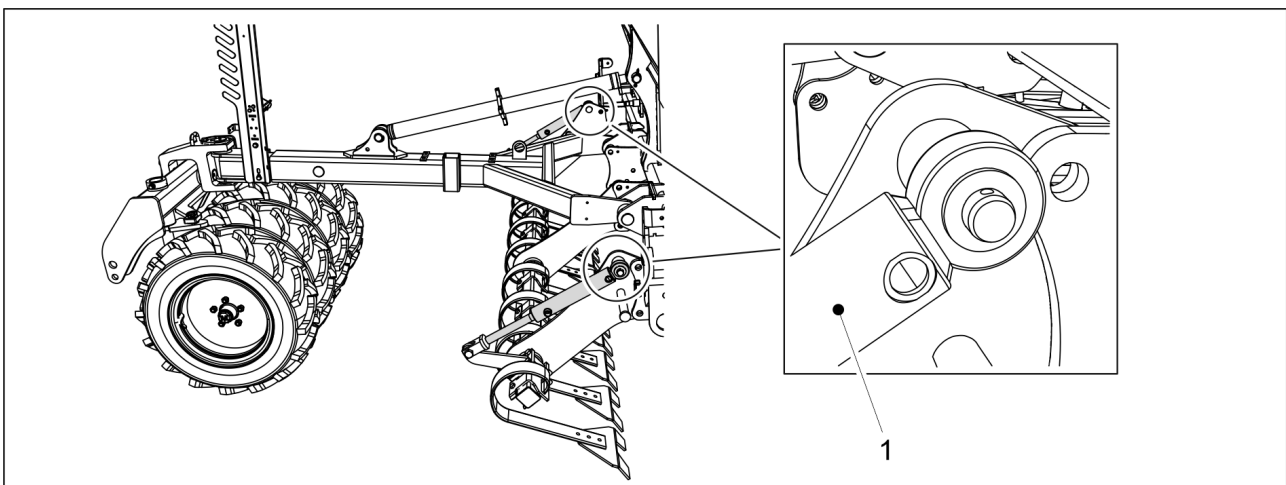

Figure. 7.2.11 - 255. Front levelling board cylinders

1. Lubricate the two front levelling board cylinders (1).
 - There is one grease nipple at the top of both cylinders.

7.2.12 Lubricating the front harrow cylinders

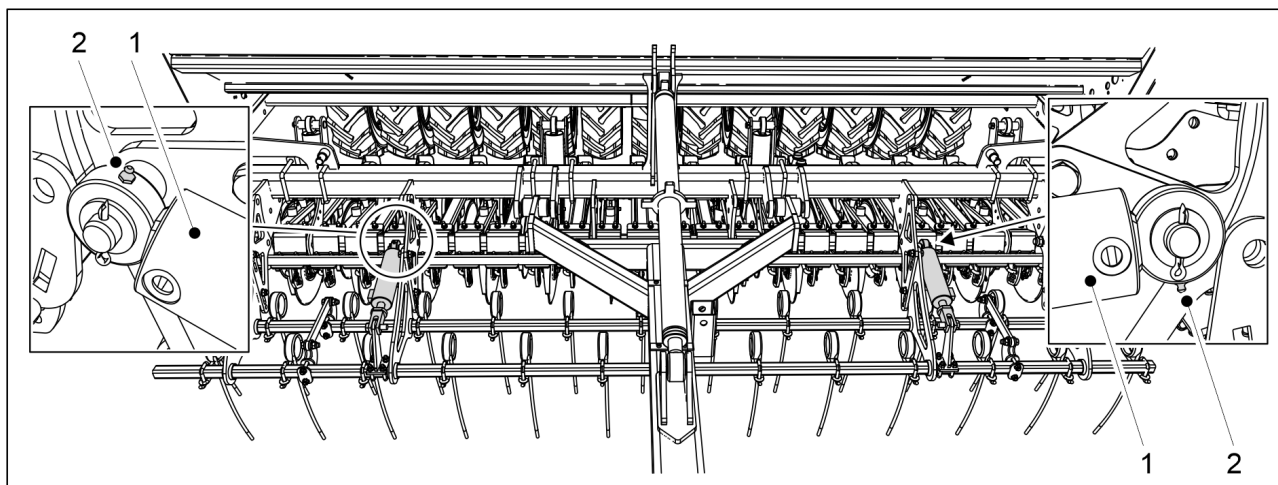

Figure. 7.2.12 - 256. Front harrow cylinders

1. Lubricate the 2 front harrow cylinders (1).
 - The grease nipples (2) are on the piston side of the cylinder.

7.2.13 Lubricating the front disc cultivator cylinders

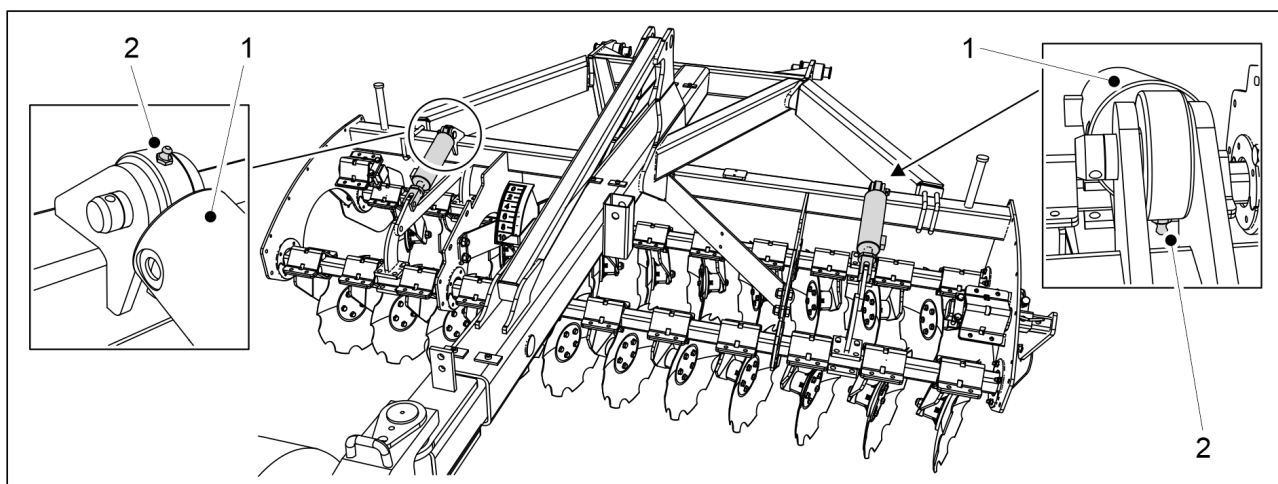

Figure. 7.2.13 - 257. Front disc cultivator cylinders

1. Lubricate the 2 front disc cultivator cylinders (1).
 - The grease nipples (2) are on the piston side of the cylinder.

7.2.14 Lubricating the drawbar cylinder

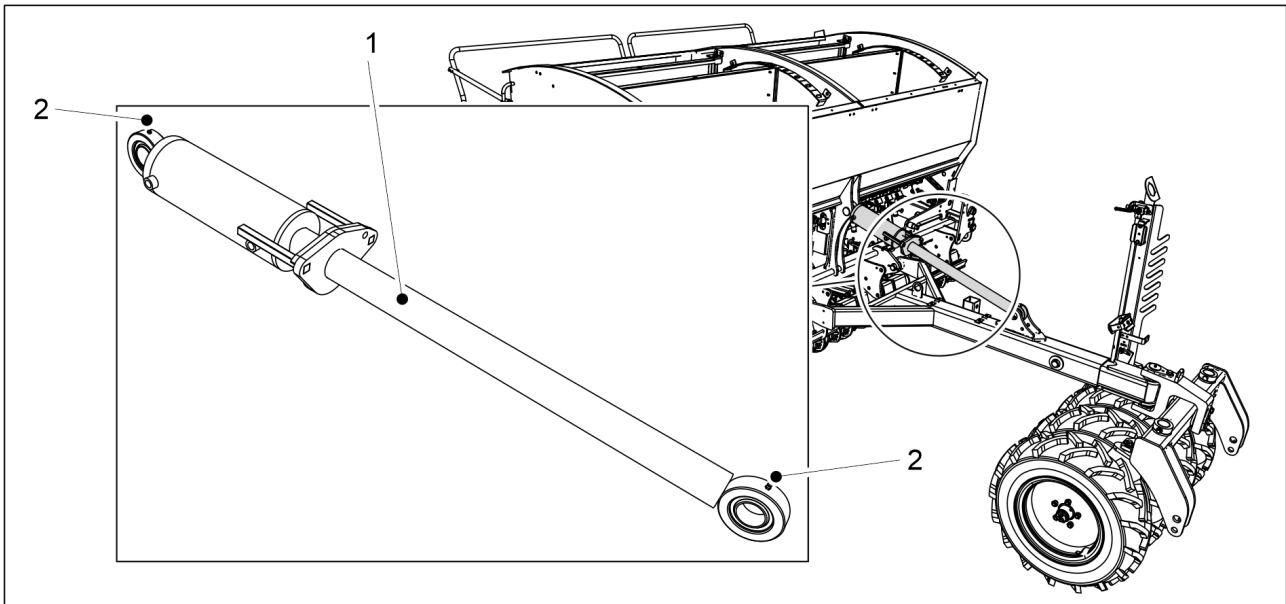

Figure. 7.2.14 - 258. Drawbar cylinder

1. Lubricate the drawbar cylinder (1).
 - There is a grease nipple (2) at the top and bottom of the drawbar cylinder.

7.2.15 Lubricating the turnbuckle

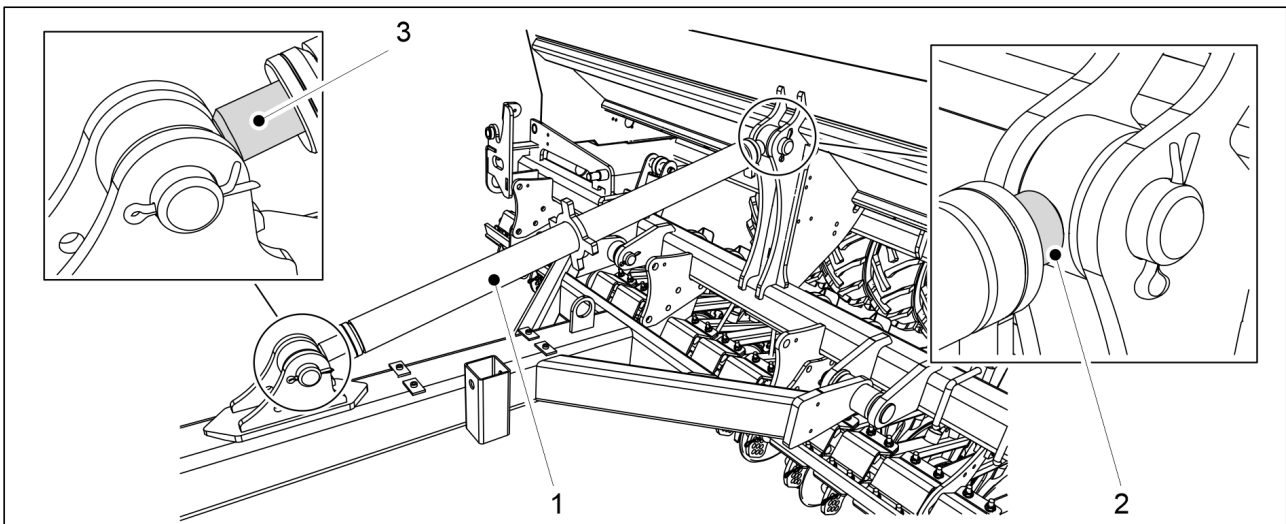

Figure. 7.2.15 - 259. Turnbuckle

1. Lubricate the turnbuckle (1) threads from both ends (2, 3).

7.2.16 Lubricating the parking brake lever shafts

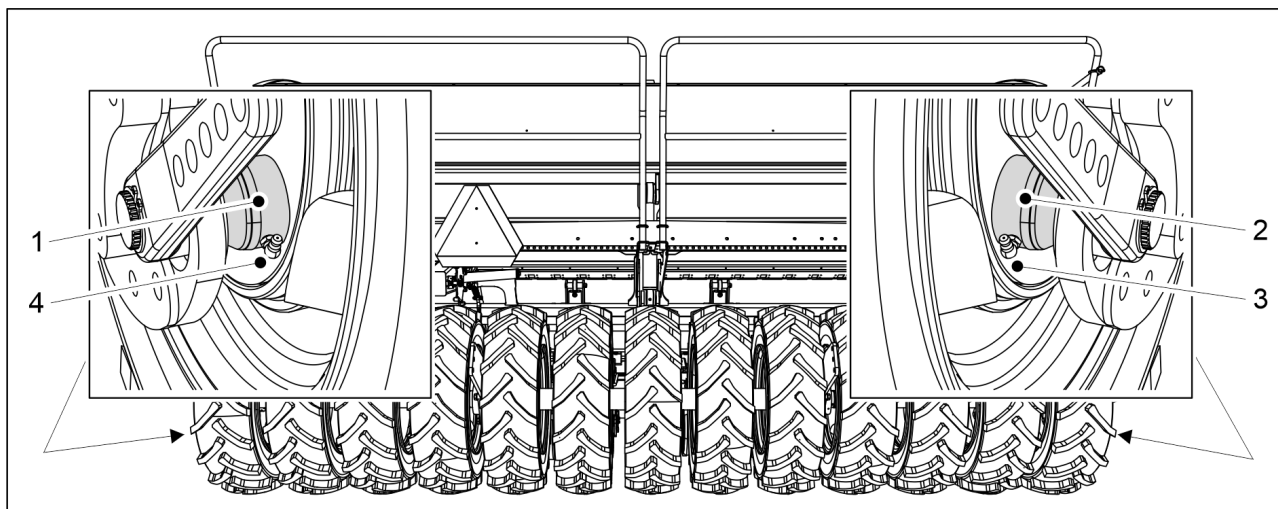

Figure. 7.2.16 - 260. Parking brake lever shafts

1. Lubricate the parking brake lever shafts (1, 2) through the grease nipples (3, 4).

7.2.17 Lubricating the parking brake crank

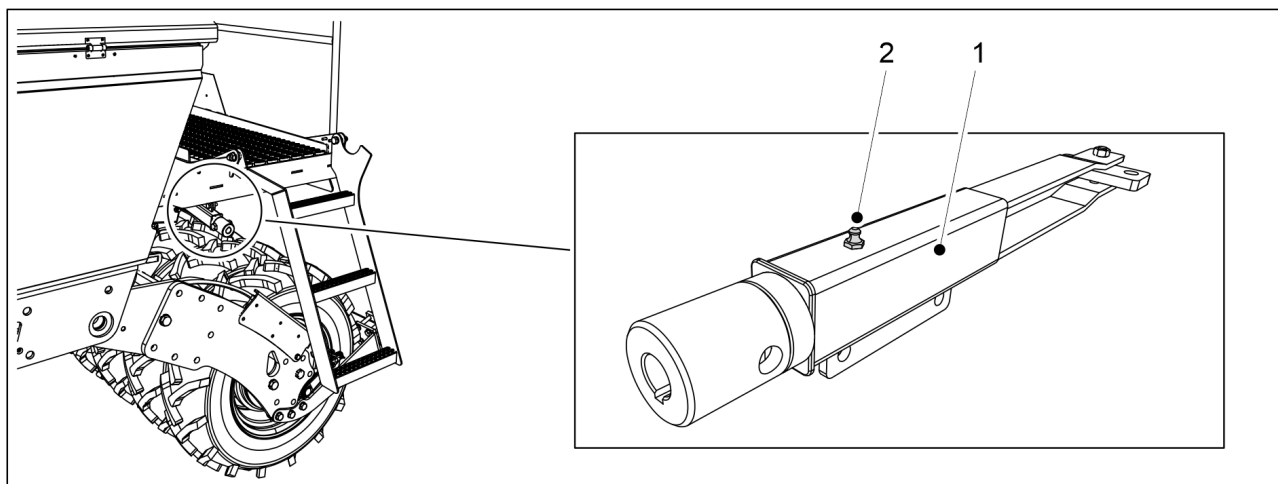

Figure. 7.2.17 - 261. Parking brake crank

1. Lubricate the parking brake crank (1) through the grease nipple (2).

7.2.18 Lubricating the transport wheels centre axle lift cylinder

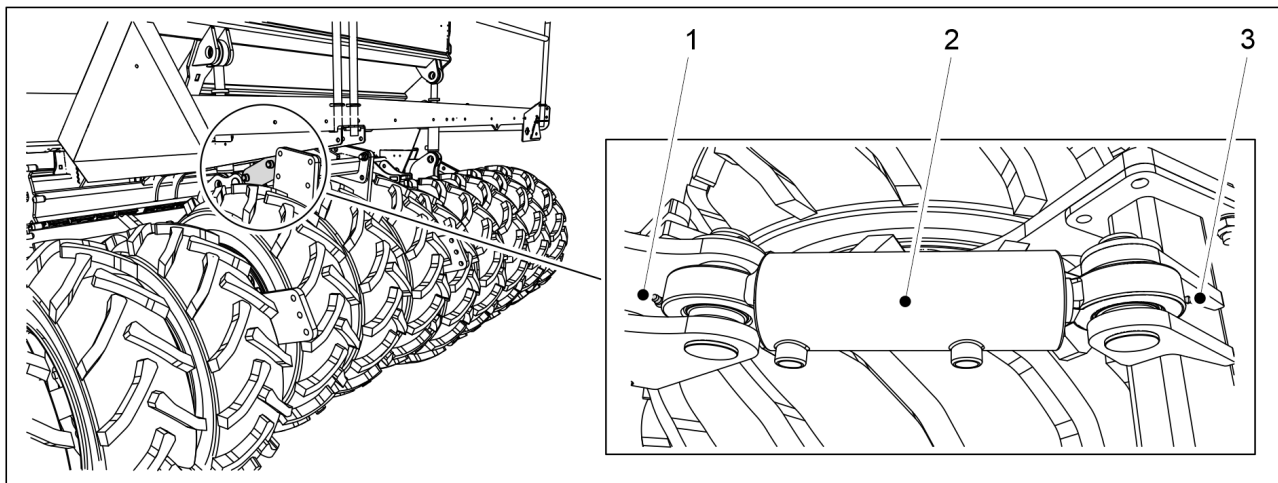

Figure. 7.2.18 - 262. Transport wheel centre axle lift cylinder

1. Lubricate the lift cylinder (2) through the grease nipples (1, 3).

7.3 Cleaning

7.3.1 Cleaning the hoppers

- Wear protective goggles and protective gloves when cleaning the hoppers. Clean the small seed hopper when the variety to be seeded changes and at the end of the seeding season. Empty and clean the fertiliser hopper and wash fertiliser off the machine when taking a break from seeding and at the end of the season.

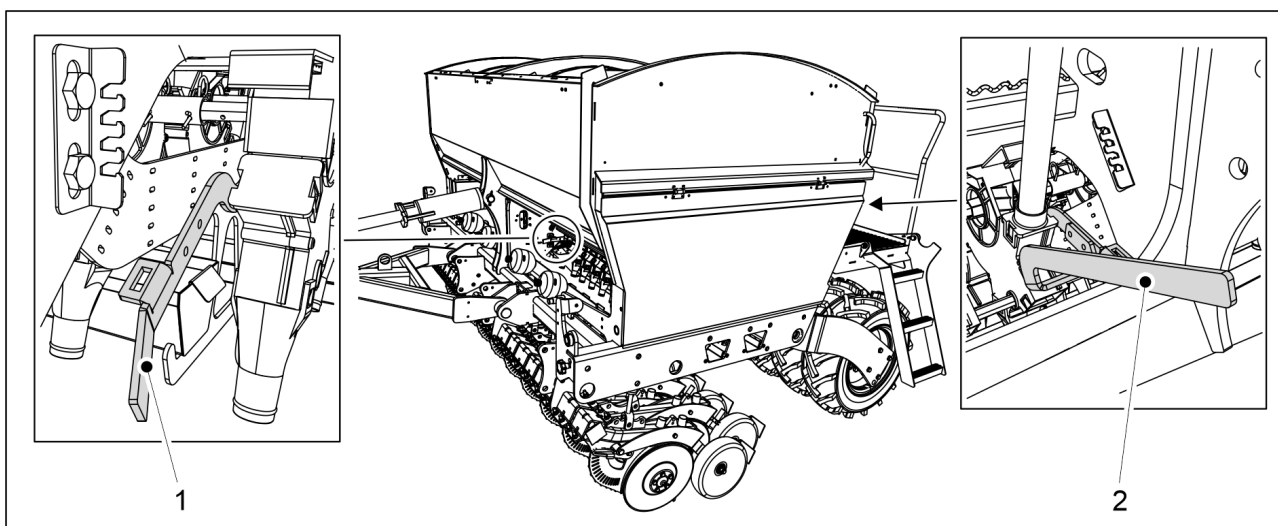

Figure. 7.3.1 - 263. Bottom flaps open

1. Open the fertiliser feeder unit bottom flap at the front of the seed drill by turning the control lever (1) downward.
2. Open the seed feeder unit bottom flap at the rear of the seed drill by turning the control lever (2) downward.

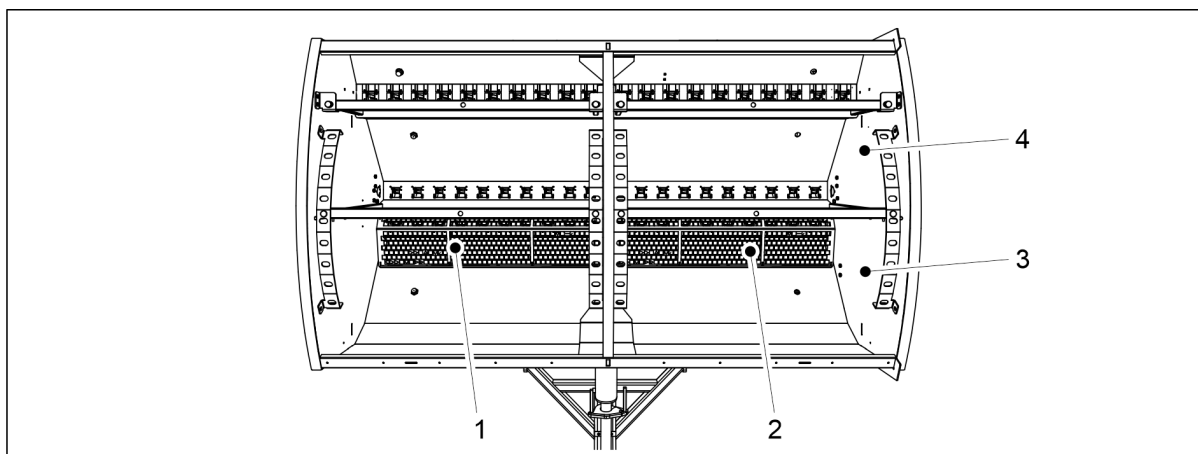

Figure. 7.3.1 - 264. Cleaning the hoppers

3. Remove the sieves (1, 2) of the fertiliser hopper (3).
4. Clean the fertiliser hopper with pressurised air.
5. Wash the fertiliser hopper (3) and seed hopper (4) with a detergent and warm water.
6. If needed, clean the hoppers with power wash.



CAUTION

Do not allow water to enter electrical instruments.

7. Dry the hoppers with pressurised air.
8. Close the bottom flaps of the feeder units.

7.3.2 Cleaning of the small seed hopper

- Wear protective goggles and protective gloves when cleaning the hoppers. Clean the small seed hopper when the variety to be seeded changes and at the end of the seeding season.

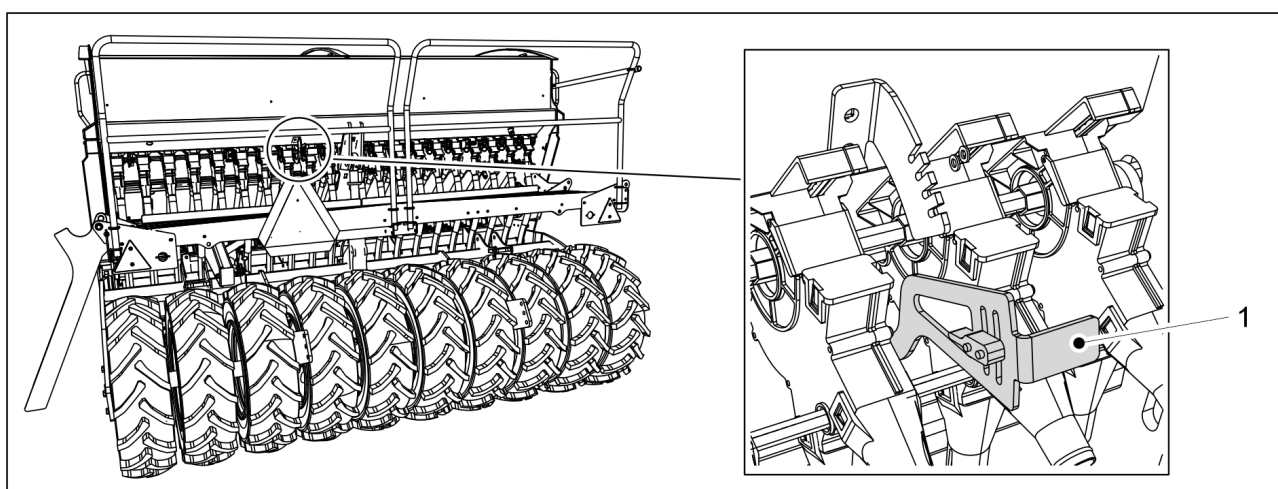

Figure. 7.3.2 - 265. Bottom flap open

1. Open the bottom flap by turning the control lever (1) downward.

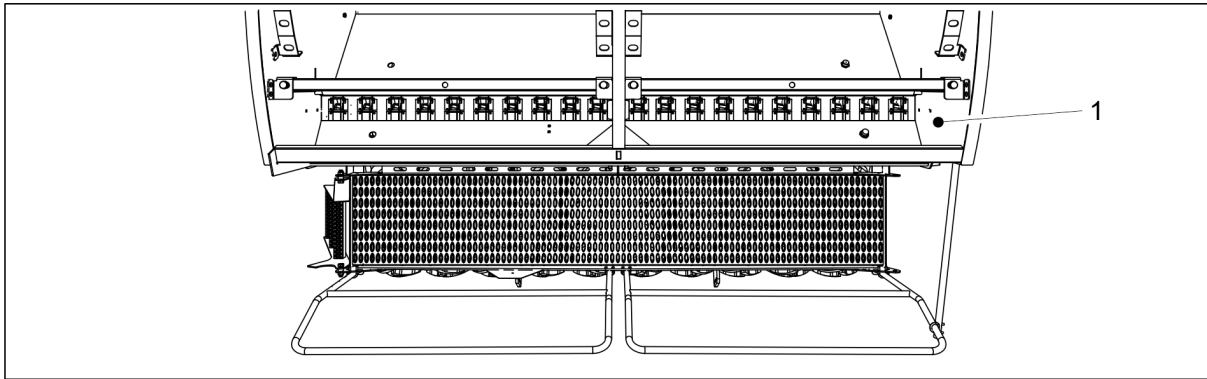

Figure. 7.3.2 - 266. Cleaning of the small seed hopper

2. Clean the small seed hopper (1) with pressurised air.
3. Wash the small seed hopper with detergent and warm water.
4. If needed, clean the hopper with a pressure washer.



CAUTION
Do not allow water to enter electrical instruments.

5. Dry the hopper with pressurised air.
6. Close the bottom flap of the feeder unit.

7.3.3 Cleaning the paint surface

- Wear protective goggles and protective gloves when cleaning the paint surface. Clean the paint surface at the end of the seeding season.

1. Clean the seed drill's paint surface brushing and using pressurised air.
2. If needed, clean the paint surface with power wash.



CAUTION
Do not allow water to enter electrical instruments.

3. Lubricate all lubrication points in accordance with section 7.2 Lubrication .

- Damaged paint can be touched up after washing. The painted surface can be protected with a light application of oil, using protective oil intended for the purpose. Entry of protective oil on rubber and plastic parts should be avoided.

7.3.4 Cleaning the coulter discs

- Wear protective goggles and protective gloves when cleaning the discs of the coulters.

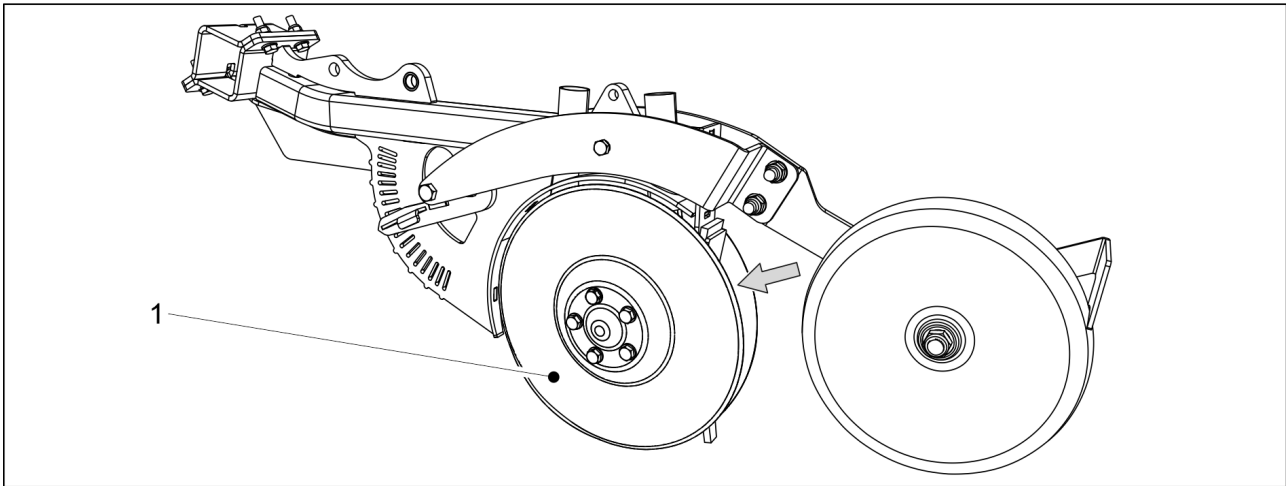

Figure. 7.3.4 - 267. Coulter discs

1. Clean the discs (1) of the coulters with a pressure washer.
 - Clean the clearance between the scraper and covering wheel as well.
2. Apply protective oil on wear parts to protect them from corrosion.
3. Once the discs are dry, turn each pair of coulter discs a few turns so that the scrapers remove the dry dirt from the inside of the discs.

7.3.5 Cleaning the feeder units

- Wear protective goggles and protective gloves when cleaning the feeder .
Clean the feeder units at the end of the seeding season.

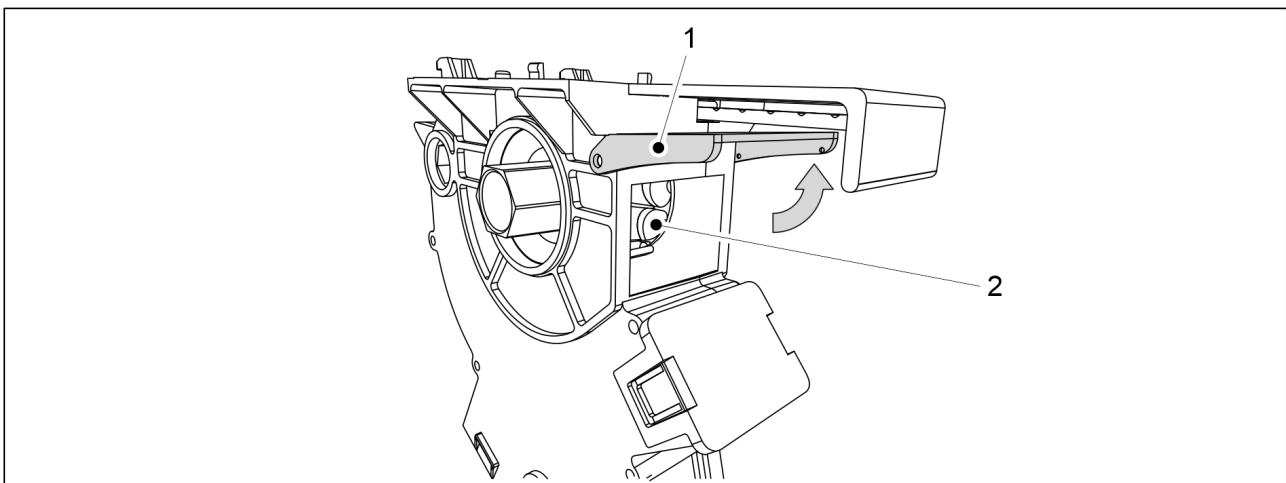

Figure. 7.3.5 - 268. Cleaning the feeder units

1. Turn the feeder cleaning hatch (1) up.
2. Clean the grooves of the feed roller (2) with a wooden stick and water and by blowing with compressed air.

7.3.6 Cleaning of the small seed hopper feeder units

- Wear protective goggles and protective gloves when cleaning the feeder .
Clean the feeder units at the end of the seeding season.

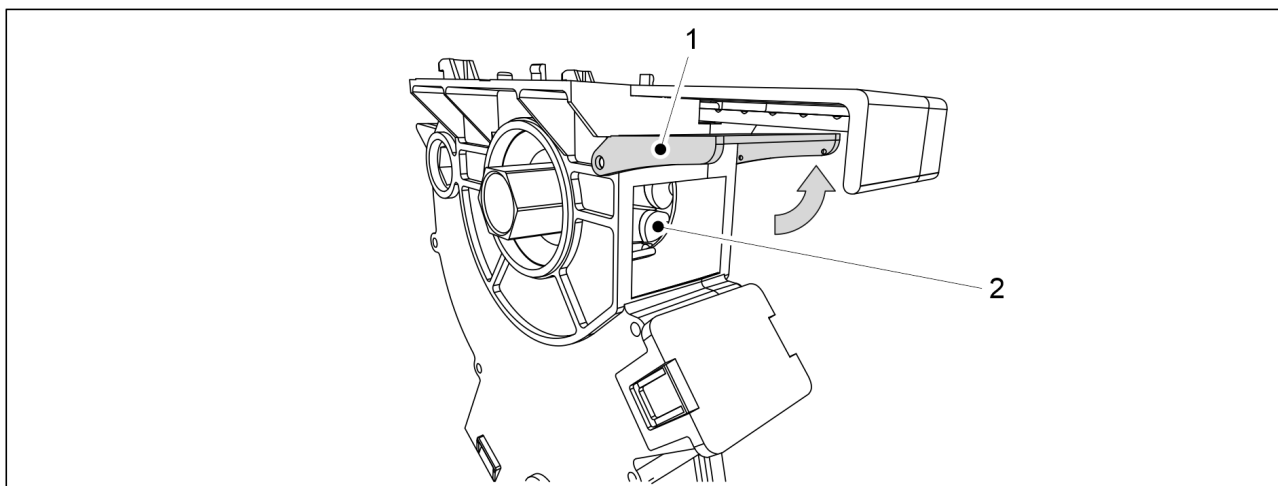

Figure. 7.3.6 - 269. Cleaning of the small seed hopper feeder units

1. Turn the feeder cleaning hatch (1) up.
2. Clean the grooves of the feed roller (2) with a wooden stick and water and by blowing with compressed air.

7.4 Transport wheel assembly

- This chapter described the dismounting and mounting of the wheel assembly. If you are unsure about how to perform the work, contact maintenance.

7.4.1 Dismounting the wheel assembly



DANGER

Crushing and cutting hazard when removing the wheels.



DANGER

Ensure that the seed drill is properly in place and that the machine is in the transport position. Ensure that the seed drill cannot move in any direction.



DANGER

The wheel assembly dismounting should be carried out by two people.

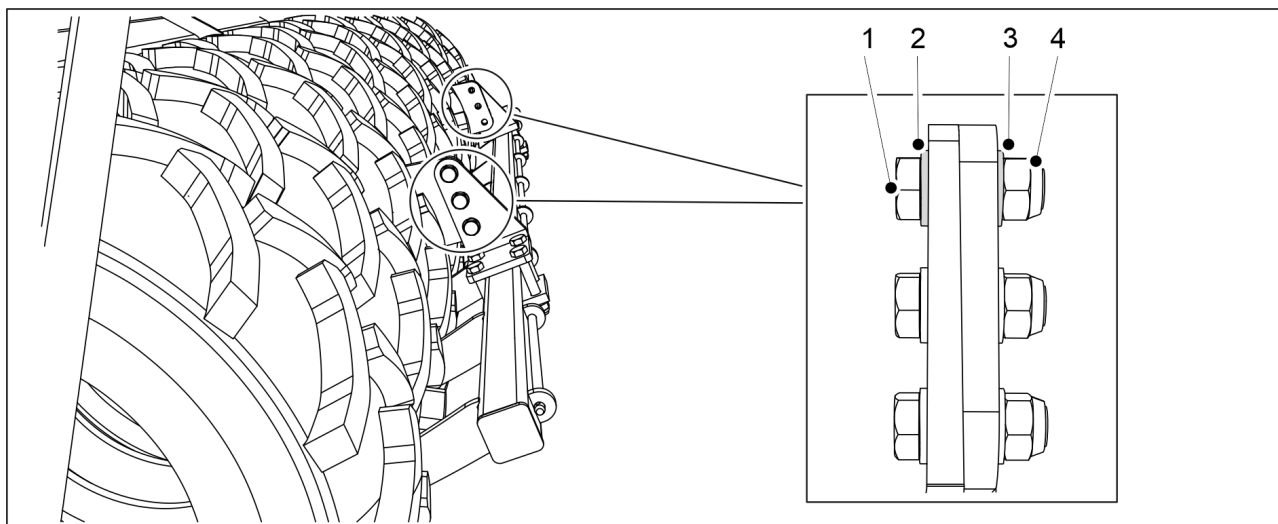

Figure. 7.4.1 - 270. Dismounting the scraper

1. If the machine is equipped with a scraper, dismount it by removing the bolts (1), washers (2, 3) and nuts (4).

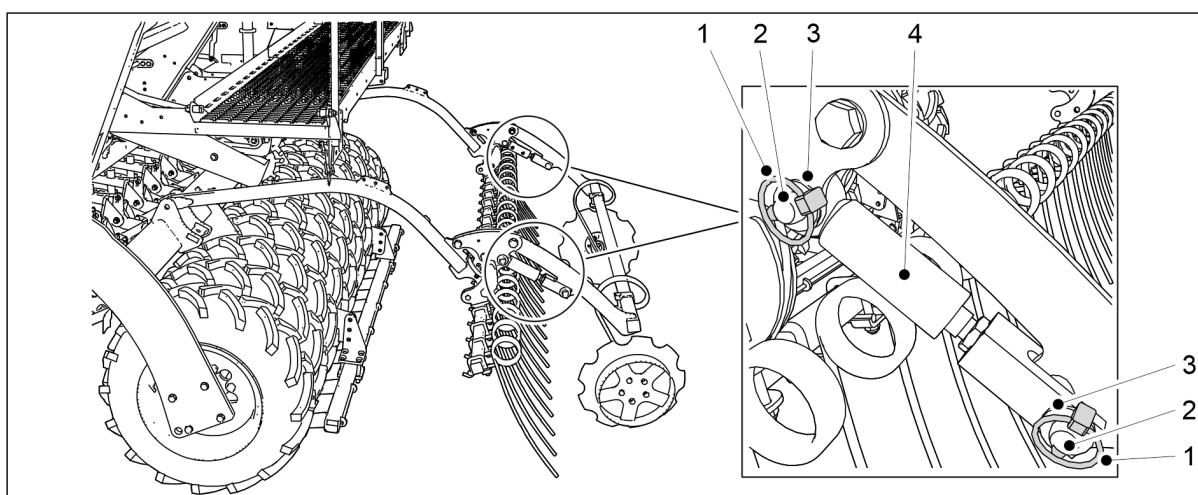

Figure. 7.4.1 - 271. Removal of the rear marker cylinders.

2. Remove the 2 rear marker cylinders (4) by removing the cotters (1), pins (6) and washers (3).
3. Place the cylinders on the working platform.

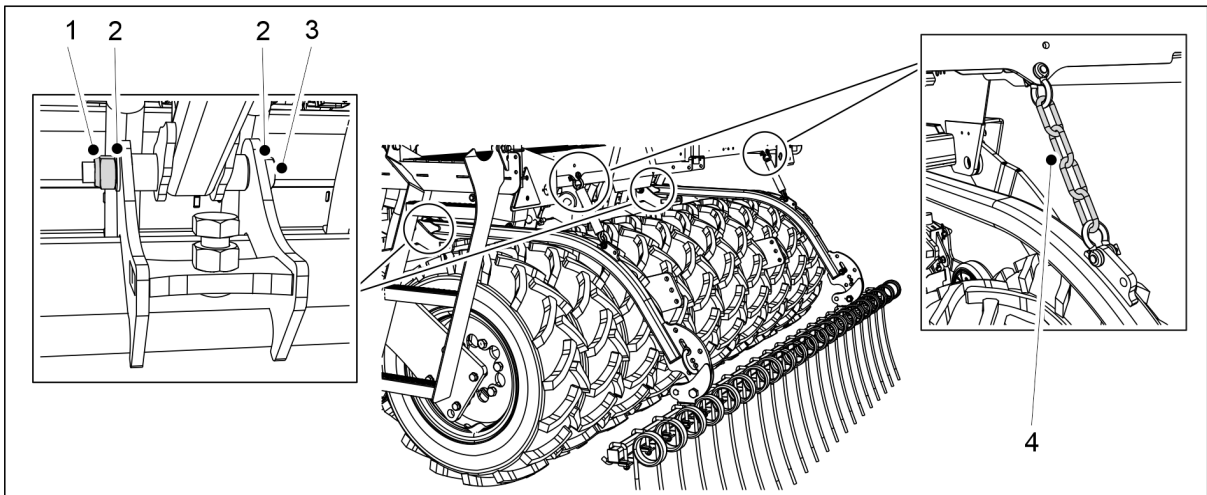

Figure. 7.4.1 - 272. Dismounting the rear harrow

4. If the machine is equipped with a rear harrow, dismount the rear harrow by removing the bolts (3), washers (2) and nuts (1) of the rear harrow shaft and detaching the rear harrow chains (4) from the working platform.

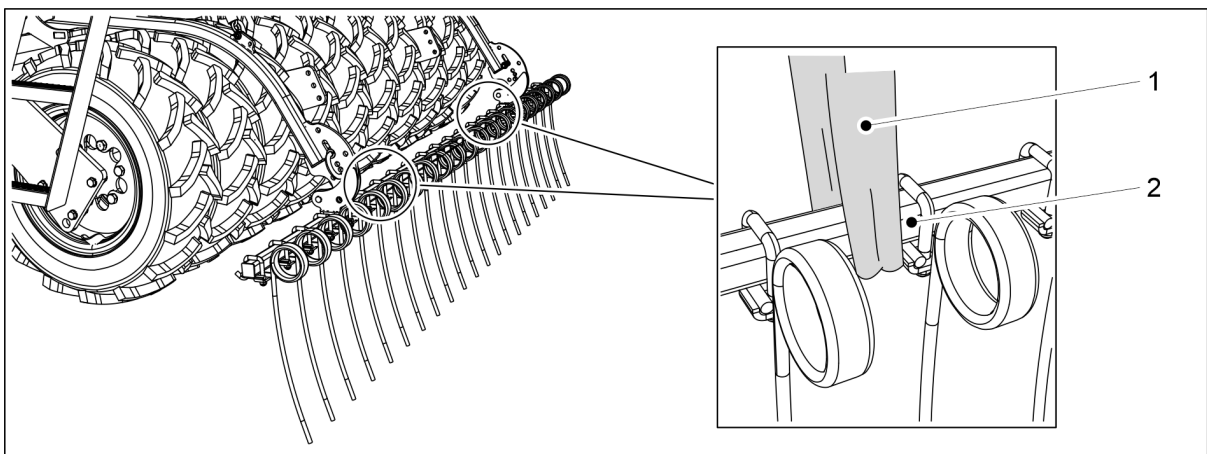

Figure. 7.4.1 - 273. Lifting the rear harrow



DANGER

Use a hoisting accessory when dismounting the rear harrow. Tie a lifting sling (1) around the tube (2).

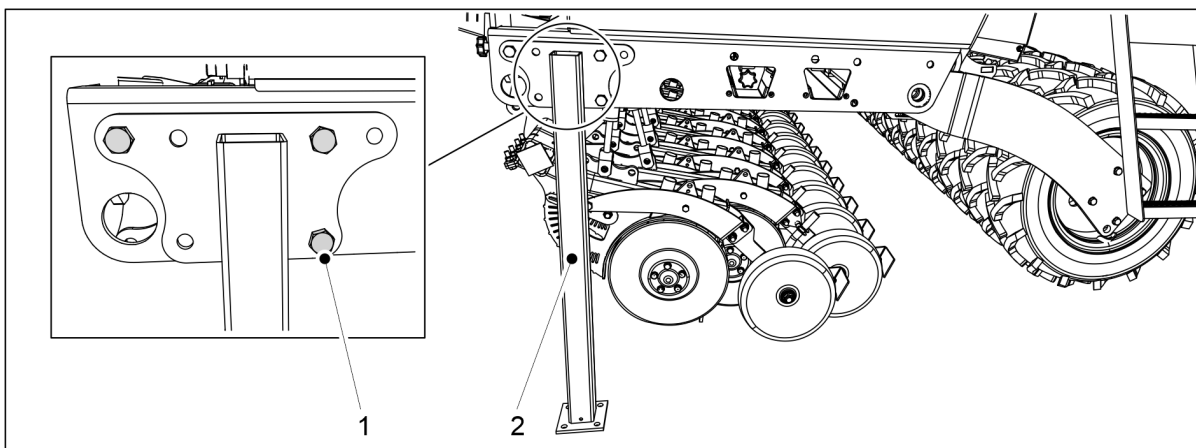

Figure. 7.4.1 - 274. Transport supports

5. Install the transport supports (2) on both sides of the seed drill with M20x50 bolts (1).

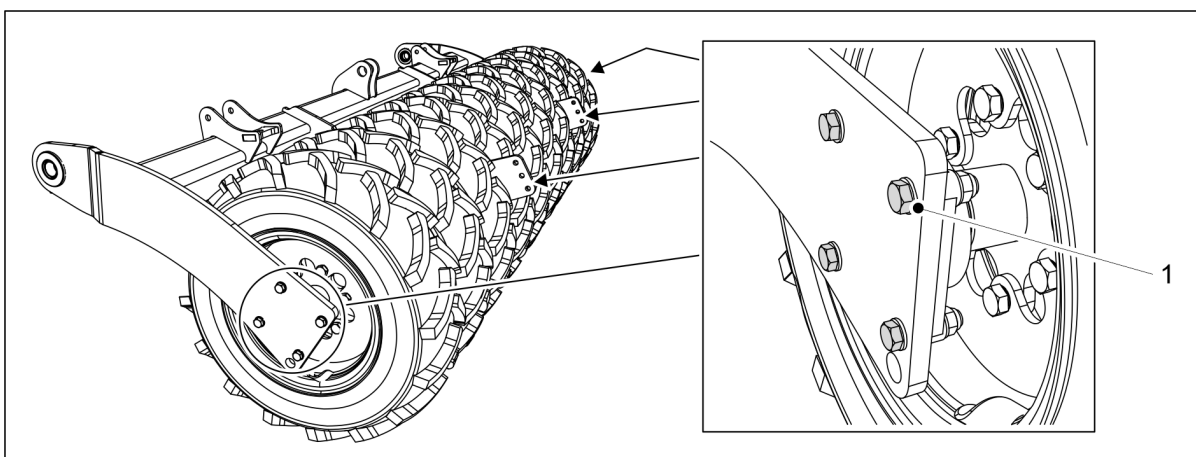

Figure. 7.4.1 - 275. Dismounting the wheel assembly

6. Remove the four bolts (1) of the flange bearing of the damaged wheel assembly from both sides of the wheel assembly.

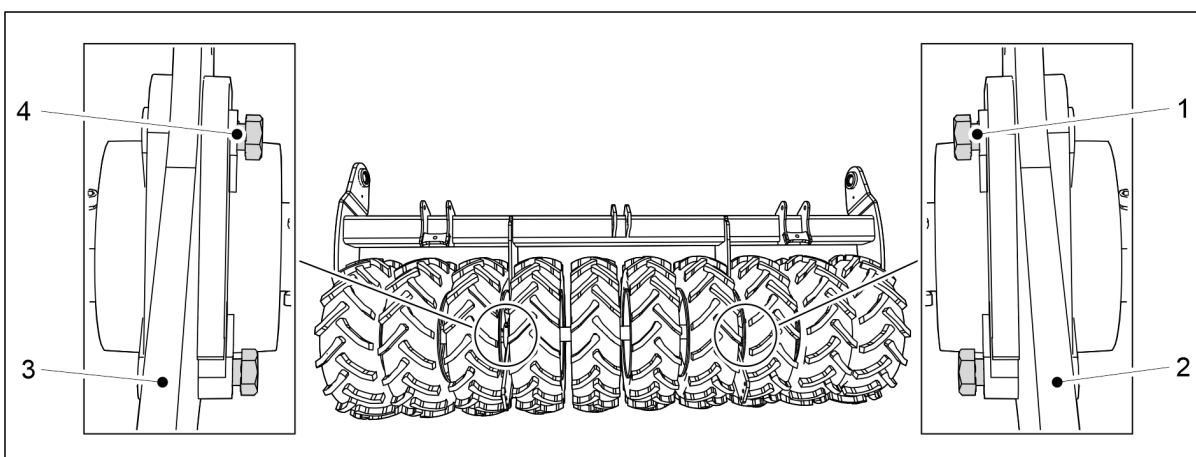

Figure. 7.4.1 - 276. Turning the bolts

7. If you are dismantling the outermost wheel assembly, turn the bearing bolts between the middle and the outermost wheel assembly to prevent the middle wheel assembly from falling.

- Ensure that the bolts do not penetrate the back of the plate (2, 3).
If you are dismantling the left-hand side wheel assembly, turn the bolts (4) so that their direction is from right to left. If you are dismantling the right-hand side wheel assembly, turn the bolts (1) so that their direction is from left to right.

8. Raise the wheel assembly slightly off the ground.

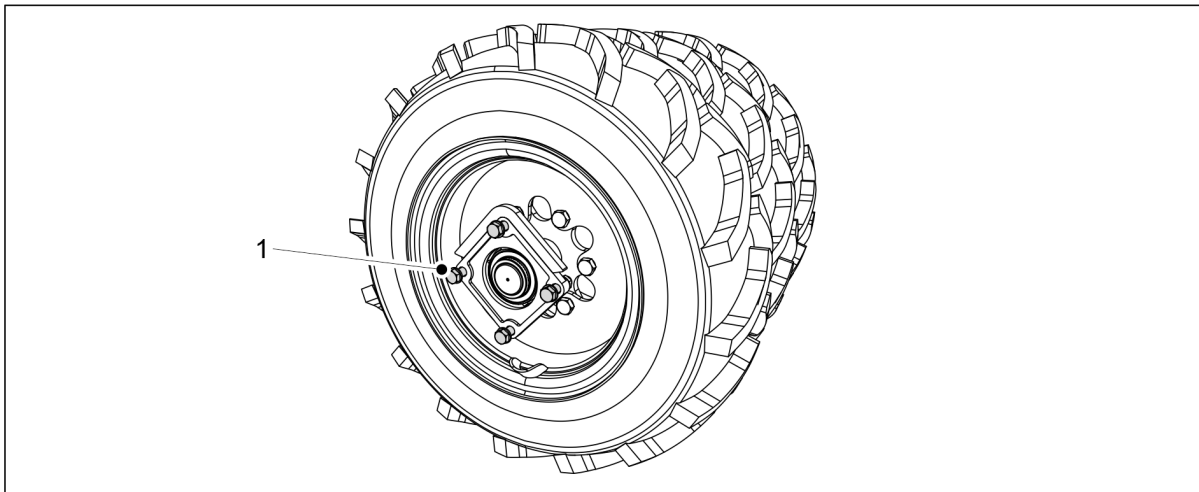

Figure. 7.4.1 - 277. The wheel assembly is supported by bolts

- The intact wheel assemblies remain supported by the bolts (1).

DANGER



Exercise caution when the wheel assembly comes loose.

7.4.2 Disassembling a wheel assembly

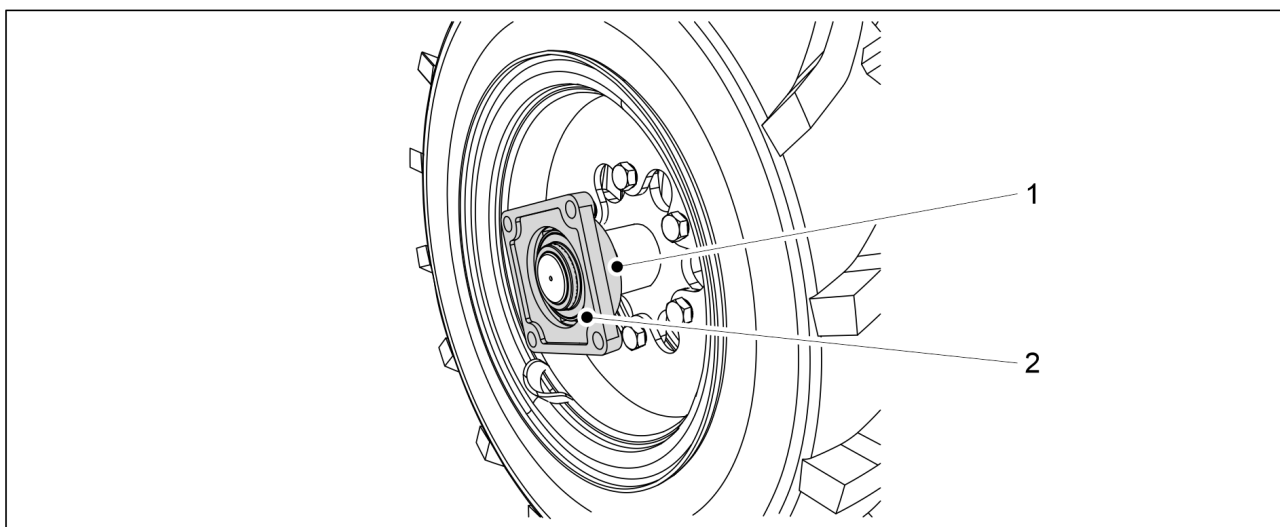

Figure. 7.4.2 - 278. Detaching a flange bearing

1. Open the locking screw (1).
2. Remove the flange bearing (2) from the axle.
 - Use an extraction tool to detach the bearing. Do not use a hammer to try to detach the bearing.
If needed, replace the bearing.

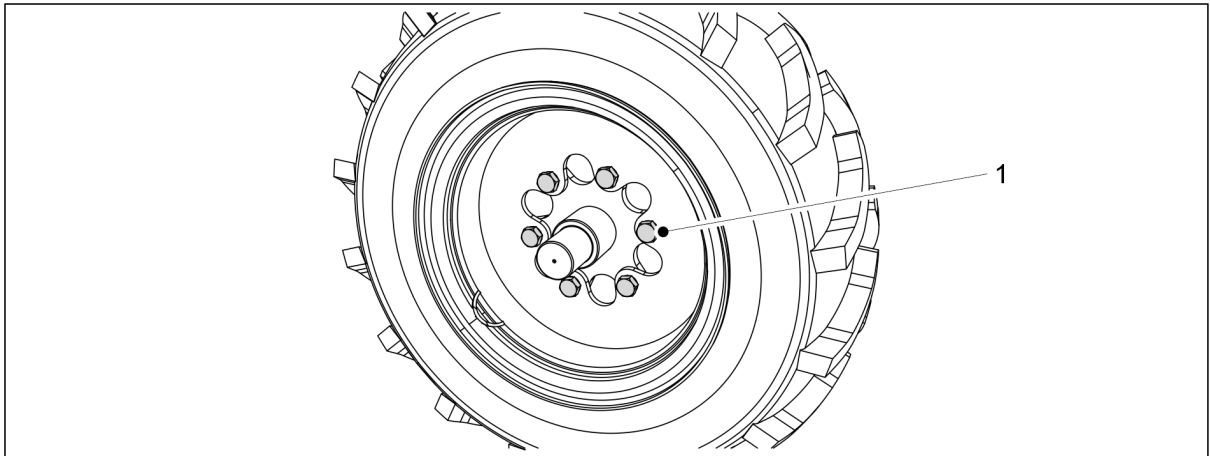

Figure. 7.4.2 - 279. Unfastening the wheel bolts

3. Remove the tyre by unfastening the six wheel bolts (1).
 - If the middle tyre of the wheel assembly needs to be replaced, the outermost tyre should also be dismantled. The tyre should be dismantled from the side of the centre tyre bolts in the pack.

7.4.3 Mounting a wheel assembly

1. Clean the surfaces before installing a wheel assembly.
2. Clean the threads of bolts.

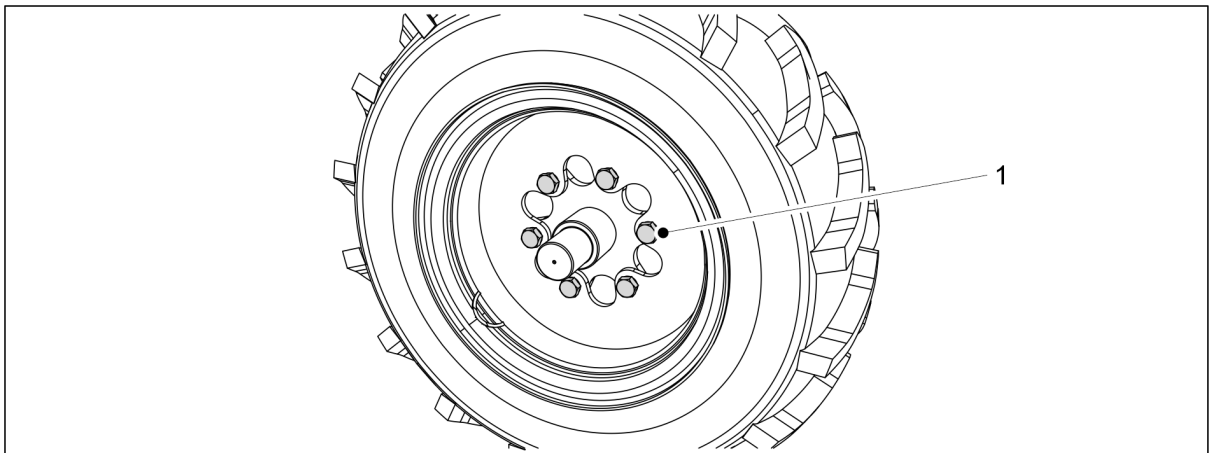

Figure. 7.4.3 - 280. Mounting a tyre

3. Mount the tyre by tightening the six wheel bolts (1).
 - The tightening torque is 350 Nm. Apply medium-hard locking compound.

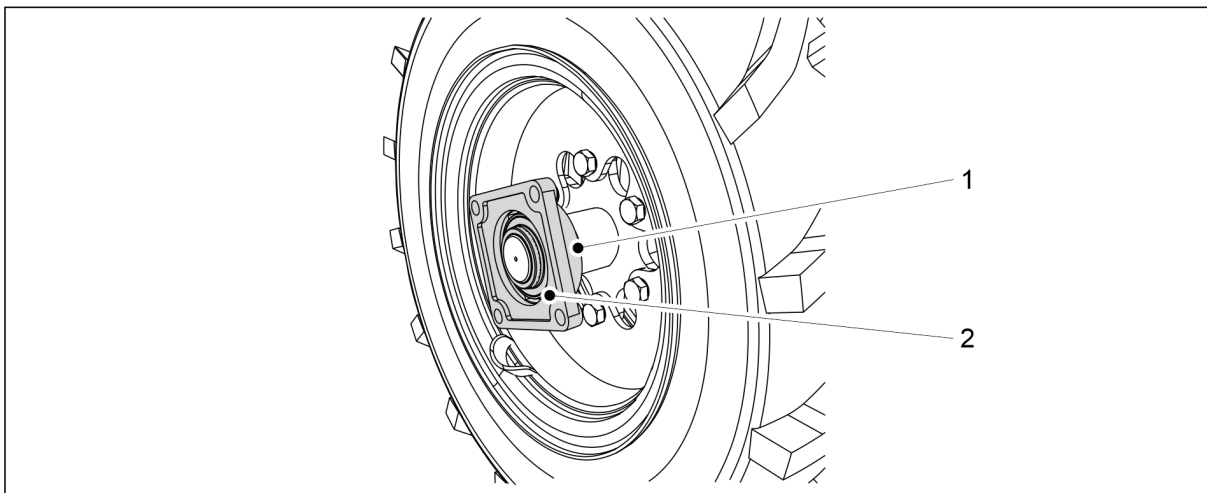

Figure. 7.4.3 - 281. Fastening the bearing

4. Fasten the flange bearing (2) to the axle and tighten the fastening screw (1).
 - If needed, replace a damaged bearing.

7.4.4 Mounting the wheel assembly

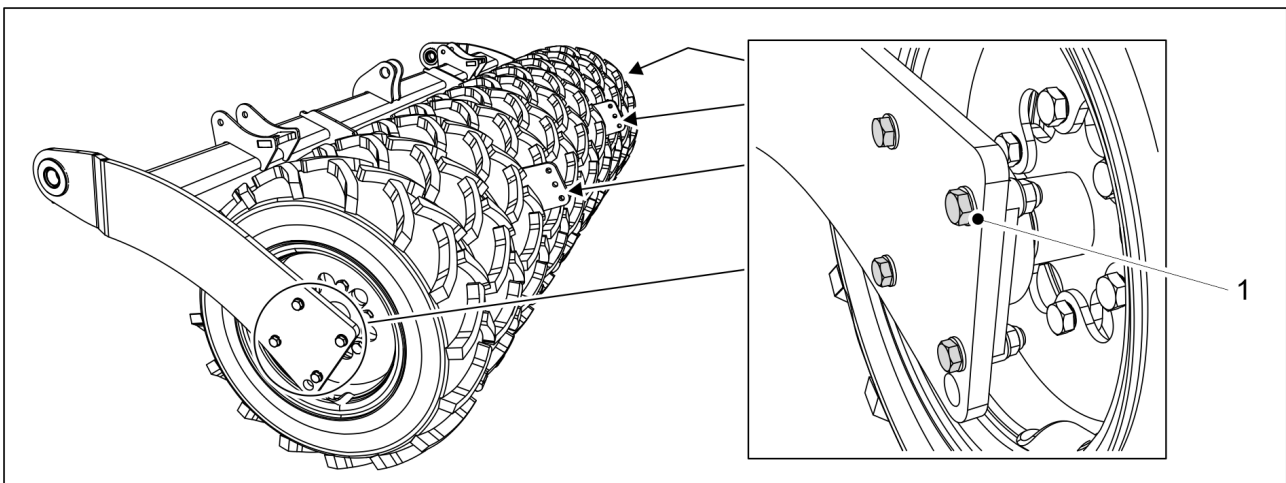

Figure. 7.4.4 - 282. Mounting the wheel assembly

1. Fasten the four bolts (1) of the flange bearing of the wheel assembly on both sides of the wheel assembly.
 - The tightening torque is 230 Nm. Use new locking nuts.
2. Remove the transport supports.
3. If necessary, mount the scraper in accordance with section [5.1.11 Mounting the scraper](#), the rear harrow in accordance with section [5.1.13 Mounting the rear harrow](#) and the rear marker cylinder in accordance with section [5.1.14 Mounting the rear markers on the rear harrow](#).
 - The wheel bolts do not need to be retightened when locking compound has been applied during installation and the bolts have been tightened to the correct torque.

7.5 Tightening the transmission chains

7.5.1 Tightening the chains, fertiliser and seed transmission

1. Lift the transmission cover on the left side of the machine.

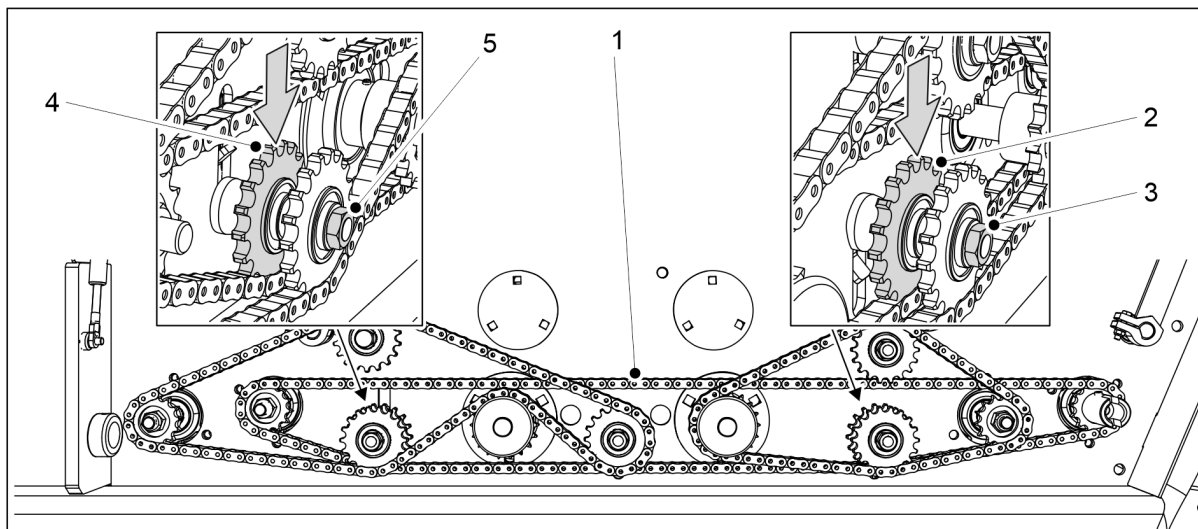

Figure. 7.5.1 - 283. Tightening the gearbox chain

2. Loosen the gearbox chain (1) by loosening the nuts (3, 5) of the chain gears (2, 4).
3. Tighten the chain by pushing down the chain gears (2, 4) to the same height.
4. Tighten the chain gear nuts.
5. Check the gearbox chain for deflection.
 - The maximum allowed chain deflection along the whole length is 15-20 mm. A chain that is too loose can rub against the bearings of the feeder shafts.

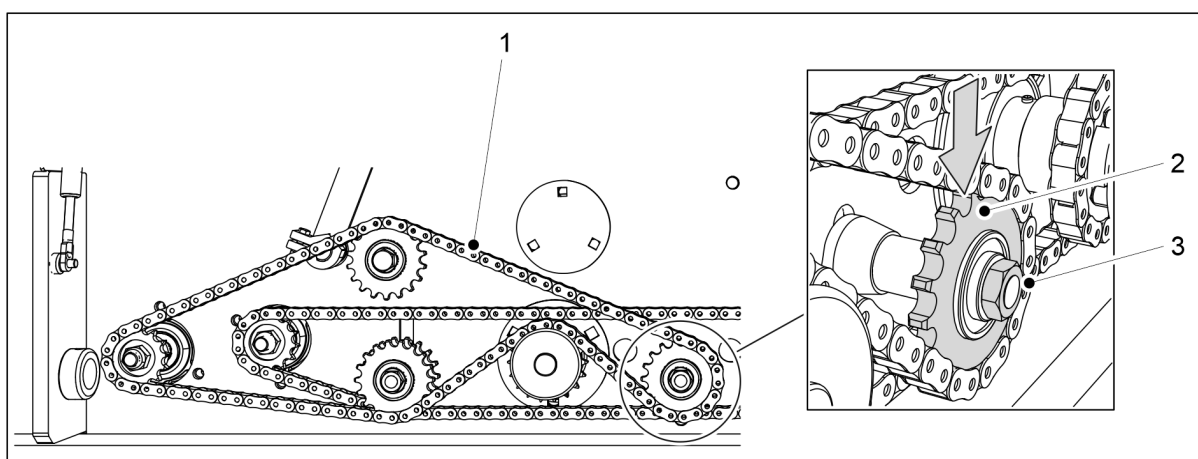

Figure. 7.5.1 - 284. Tightening the fertiliser hopper chain

6. Loosen the fertiliser hopper chain (1) by loosening the nut (3) of the chain gears (2).
7. Tighten the chain by pushing the chain gear downward.
8. Tighten the chain gear nut.
9. Check the fertiliser hopper chain for deflection.
 - The deflection should be less than 10 mm.

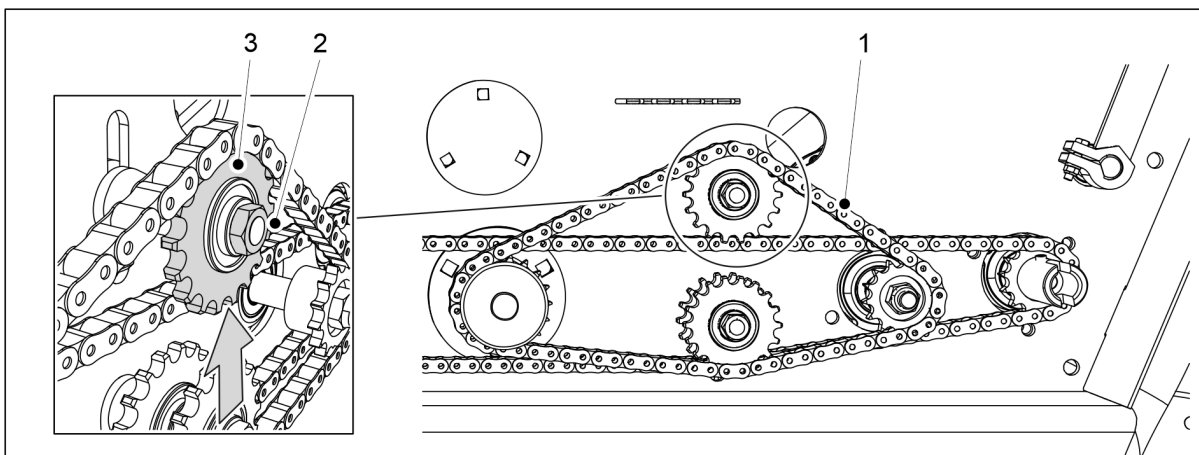

Figure. 7.5.1 - 285. Tightening the seed hopper chain

10. Loosen the seed hopper chain (1) by loosening the nut (2) of the chain gear (3).
11. Tighten the chain by lifting it up from the chain gear.
12. Tighten the chain gear nut.
13. Check the seed hopper chain for deflection.
 - The deflection should be less than 10 mm.
14. Lower the transmission cover.

7.5.2 Chain tightening, small seed transmission

1. Lift the transmission cover on the right side of the machine.

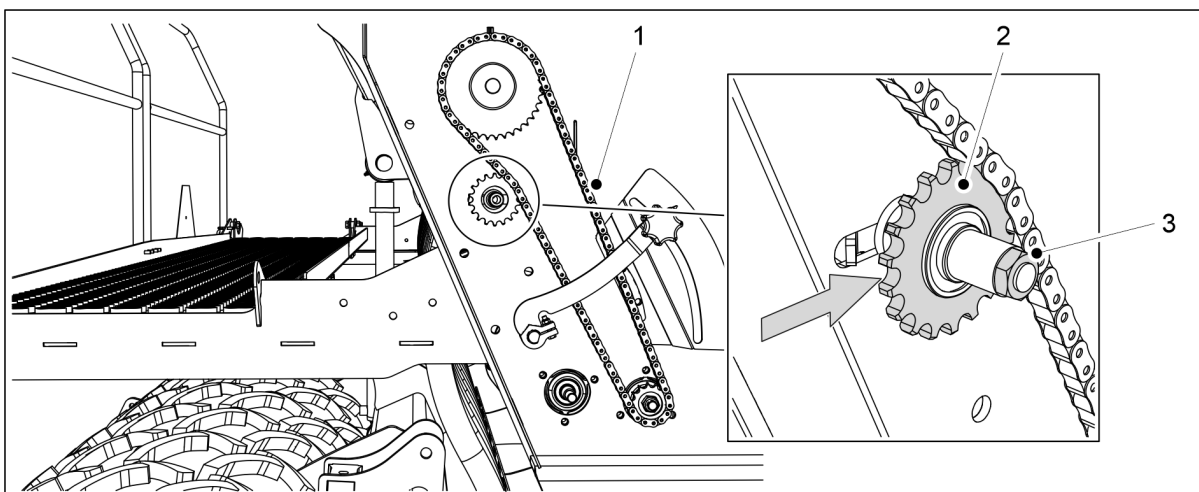

Figure. 7.5.2 - 286. Tightening the small seed hopper chain

2. Loosen the chain (1) by loosening the nut (3) of the chain gear (2).
3. Tighten the chain by moving it to the right of the chain gear in a lateral direction.
4. Tighten the chain gear nut.
5. Check the small seed hopper chain for deflection.
 - The deflection should be less than 10 mm.
6. Lower the transmission cover.

7.5.3 Chain tightening, fertiliser dispersing axle transmission

1. Lift the transmission cover on the left side of the machine.

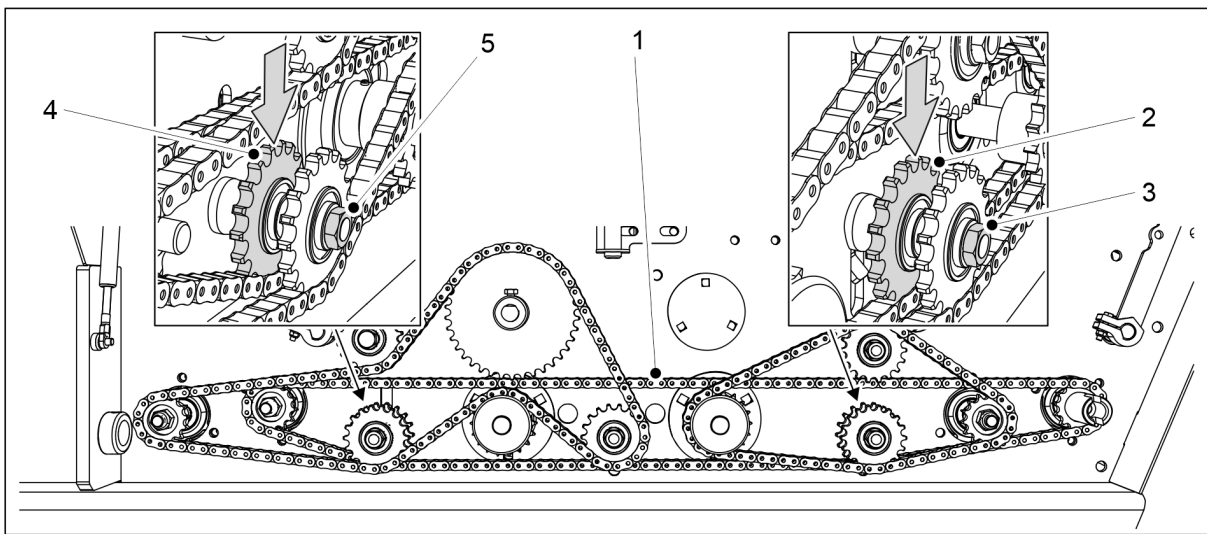

Figure. 7.5.3 - 287. Tightening the gearbox chain

2. Loosen the gearbox chain (1) by loosening the nuts (3, 5) of the chain gears (2, 4).
3. Tighten the chain by pushing down the chain gears (2, 4) to the same height.
4. Tighten the chain gear nuts.
5. Check the gearbox chain for deflection.
 - The maximum allowed chain deflection along the whole length is 15-20 mm. A chain that is too loose can rub against the bearings of the feeder shafts.

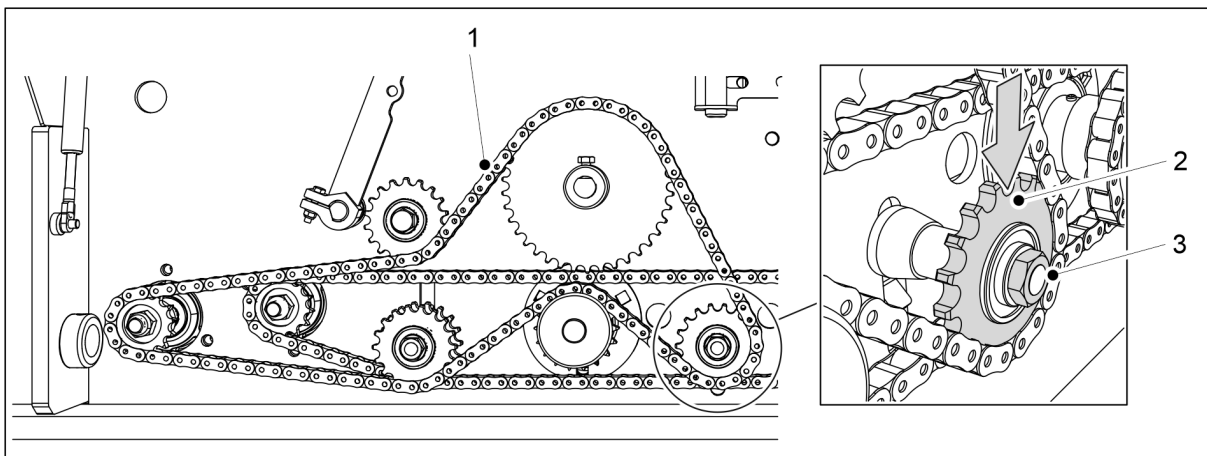

Figure. 7.5.3 - 288. Tightening the chain of the fertiliser dispersing axle

6. Loosen the fertiliser dispersing axle chain (1) by loosening the nut (3) of the chain gear (2).
7. Tighten the chain by pushing the chain gear downward.
8. Tighten the chain gear nut.
9. Check the chain for deflection.
 - The deflection should be less than 10 mm.
10. Lower the transmission cover.

7.5.4 Chain tightening, seed dispersing axle transmission

1. Lift the transmission cover on the left side of the machine.

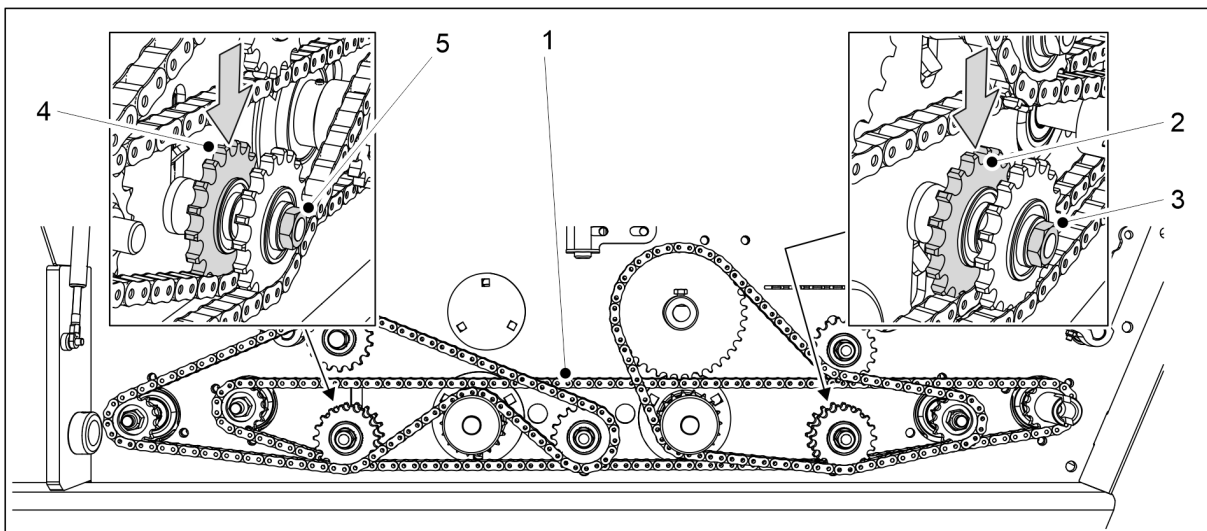

Figure. 7.5.4 - 289. Tightening the gearbox chain

2. Loosen the gearbox chain (1) by loosening the nuts (3, 5) of the chain gears (2, 4).
3. Tighten the chain by pushing down the chain gears (2, 4) to the same height.
4. Tighten the chain gear nuts.
5. Check the gearbox chain for deflection.
 - The maximum allowed chain deflection along the whole length is 15-20 mm. A chain that is too loose can rub against the bearings of the feeder shafts.

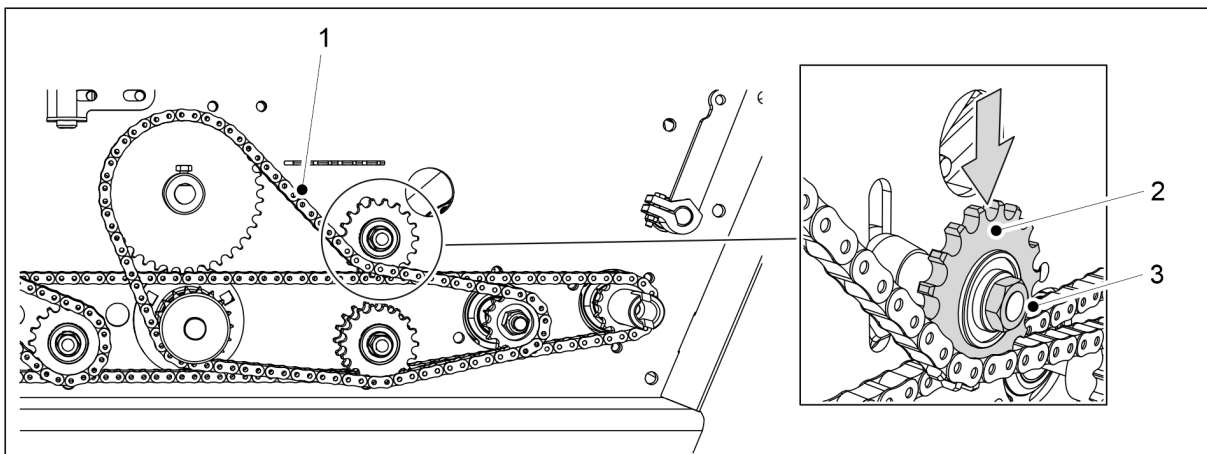

Figure. 7.5.4 - 290. Tightening the chain of the seed dispersing axle

6. Loosen the seed dispersing axle chain (1) by loosening the nut (3) of the chain gear (2).
7. Tighten the chain by pushing the chain gear downward.
8. Tighten the chain gear nut.
9. Check the chain for deflection.
 - The deflection should be less than 10 mm.
10. Lower the transmission cover.

7.6 Wheel hub bearing clearance of the wheel packer

7.6.1 Tightening the bearing

1. Raise the tyre of the wheel packer off the ground.

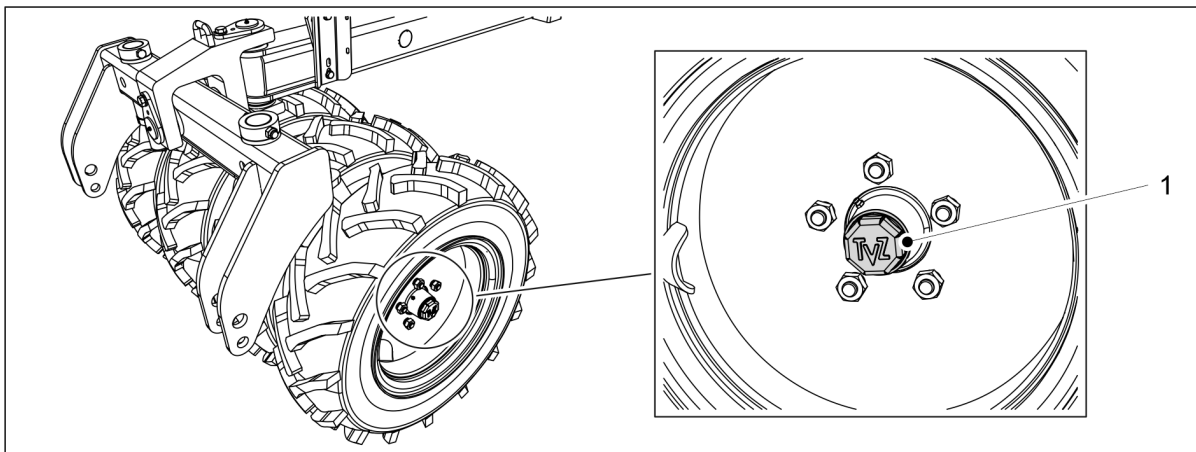

Figure. 7.6.1 - 291. Hub cap

2. Loosen the hub cap (1) by turning it counterclockwise.

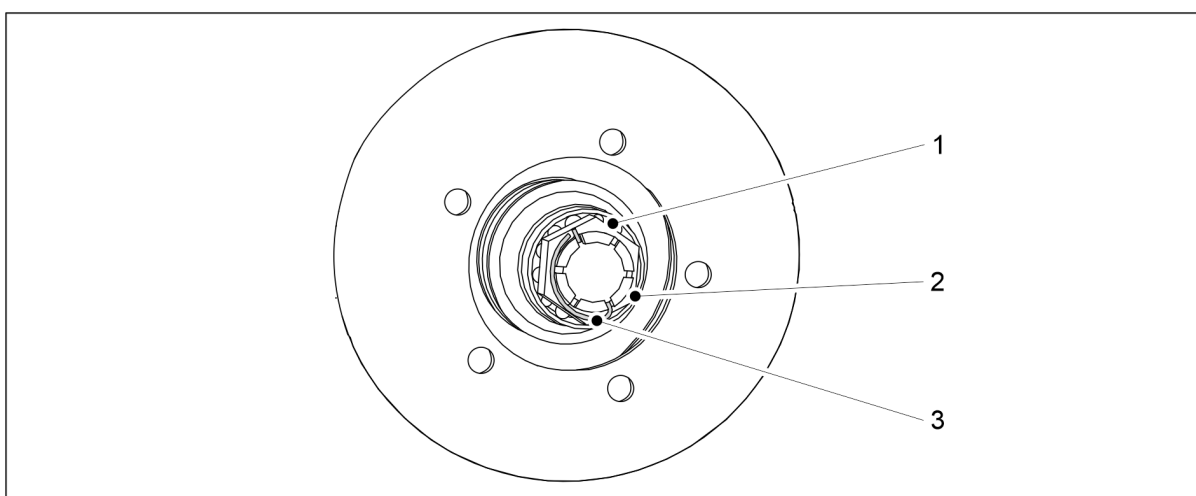

Figure. 7.6.1 - 292. Tightening the bearing of the wheel hub

3. Remove the locking pin (3) of the slotted nut (2) on the axle.
4. Tighten the nut by turning the wheel simultaneously until light resistance is felt in the bearing (1).
5. Loosen the nut until the locking pin fits into the next slot where the bearing is rotating freely.
6. Lock the pin in place.
7. Fill a third of the cup's volume with lubricant and reinstall the hub cap by turning it clockwise.
 - The tightening torque is 50 Nm.

7.7 Wheel drive

7.7.1 Tightening the wheel drive chain

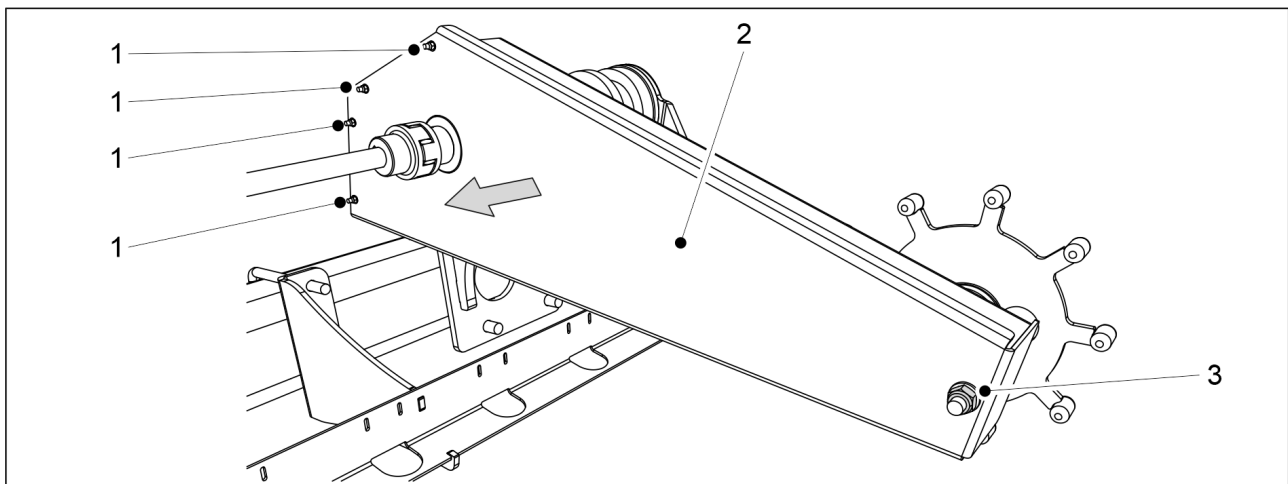

Figure. 7.7.1 - 293. Opening the wheel drive housing

1. Remove the 4 cover bolts (1) from the front end of the wheel drive housing and the cover mounting nut (3) from the rear end of the housing.
2. Remove the cover (2).

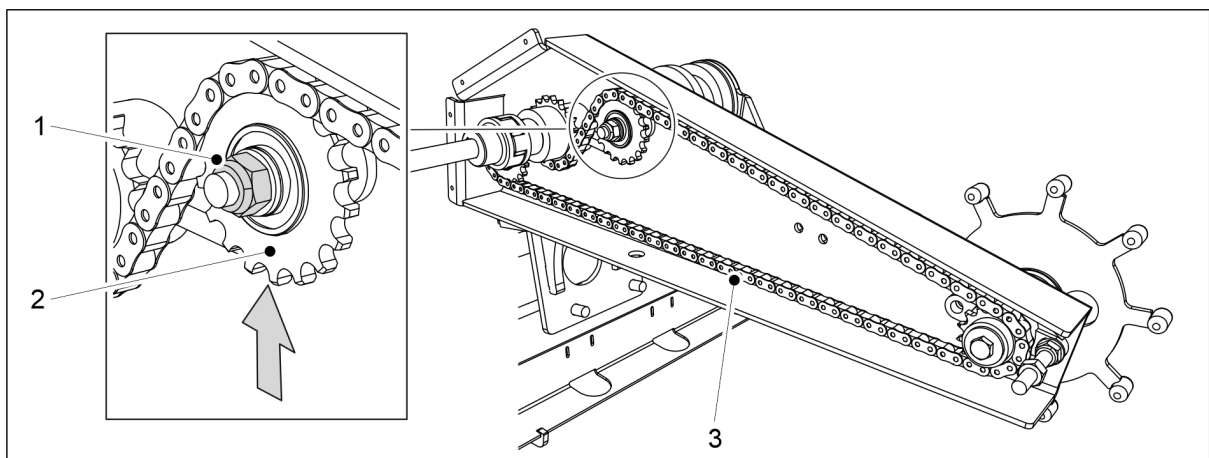

Figure. 7.7.1 - 294. Tightening the wheel drive chain

3. Loosen the nut (1) of the chain gear (2).
4. Tighten the wheel drive chain (3) by moving the chain gear upwards.
5. Tighten the nut and check the chain deflection.
 - The maximum allowed chain deflection is 10 mm.
6. Replace the cover.
7. Attach the bolt at the front end of the housing and the mounting that at the rear end of the housing.
 - Always use new locknuts to install.

7.7.2 Replacing the wheel drive clutch

7.7.2.1 Dismounting the clutch

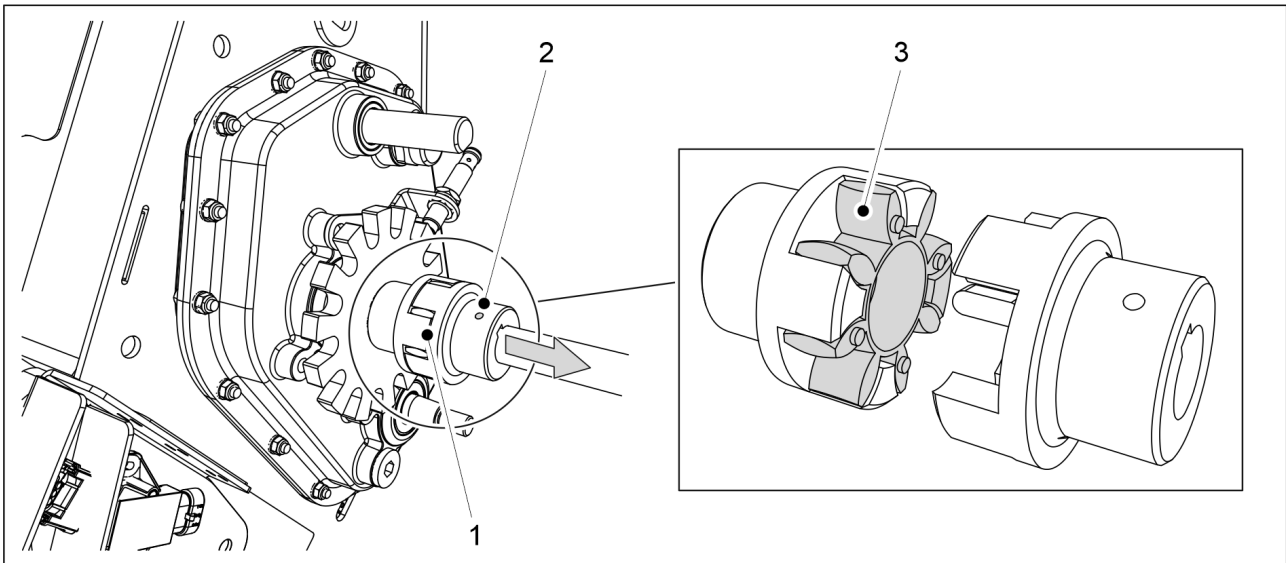

Figure. 7.7.2.1 - 295. Dismounting the clutch flexible coupling element

1. Open the locking screw (2) in the clutch body.
2. Separate the components of the clutch (1) by pulling the clutch on the axle towards the wheel drive mechanism.
3. Detach the flexible coupling element (3) of the clutch.

7.7.2.2 Installing the clutch

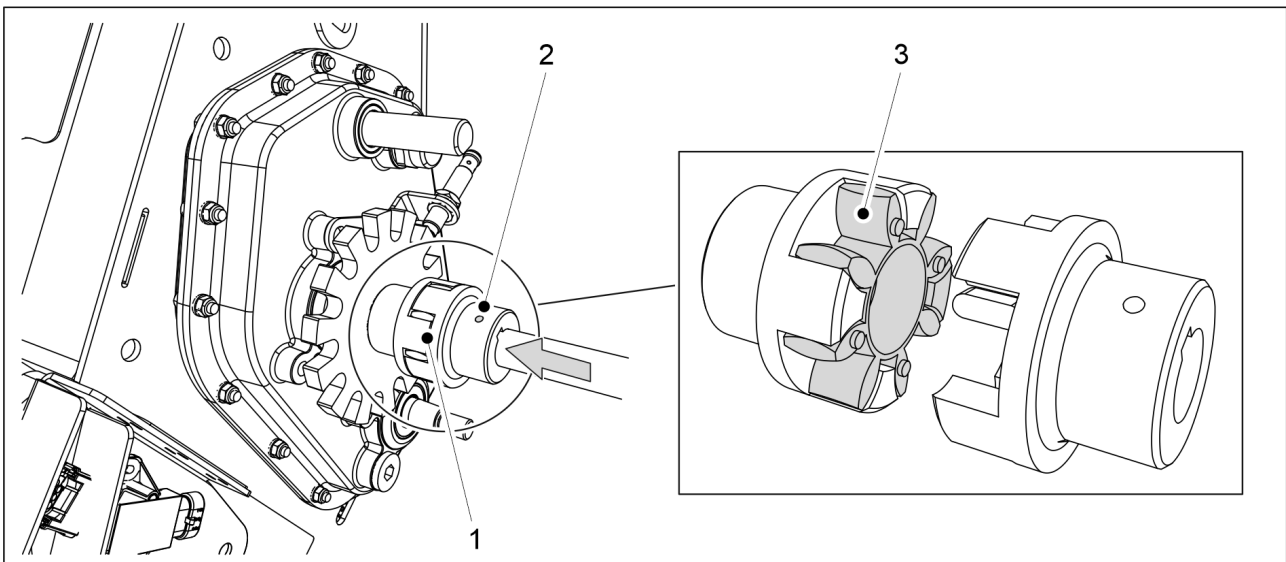

Figure. 7.7.2.2 - 296. Installing the clutch

1. Replace the flexible coupling element (3) of the clutch.
2. Push the clutch on the axle so that the clutch (1) terminals are tightly against each other.
3. Lock the clutch in place by tightening the locking screw (2).

7.8 Towing eye

7.8.1 Replacing the towing eye

7.8.1.1 Detaching the towing eye

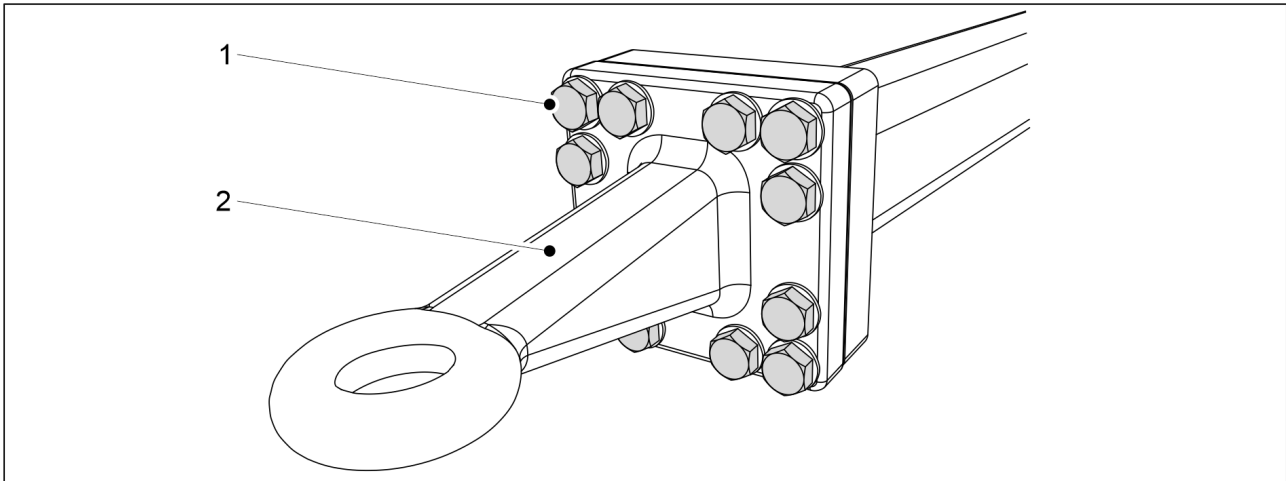

Figure. 7.8.1.1 - 297. Towing eye

1. Remove the 12 bolts (1) of the towing eye.
2. Remove the towing eye (2).

7.8.1.2 Installing the towing eye

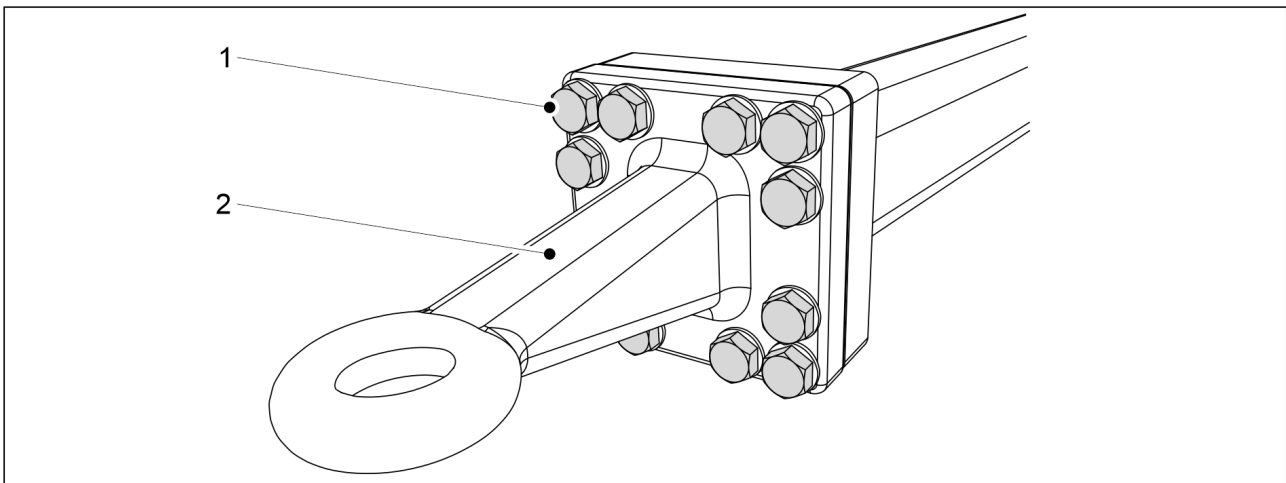

Figure. 7.8.1.2 - 298. Towing eye

1. Replace the towing eye (2).
2. Tighten the 12 bolts (1).
 - The tightening torque is 400 Nm.

7.9 Coulters



DANGER

Wear protective gloves during the servicing of the coulters.

- Wash the coulters before servicing.

7.9.1 Replacing a coulter

7.9.1.1 Demounting a coulter



DANGER

Use a lifting aid to lift and move the coulter. The coulter weighs more than 60 kg and has sharp edges.

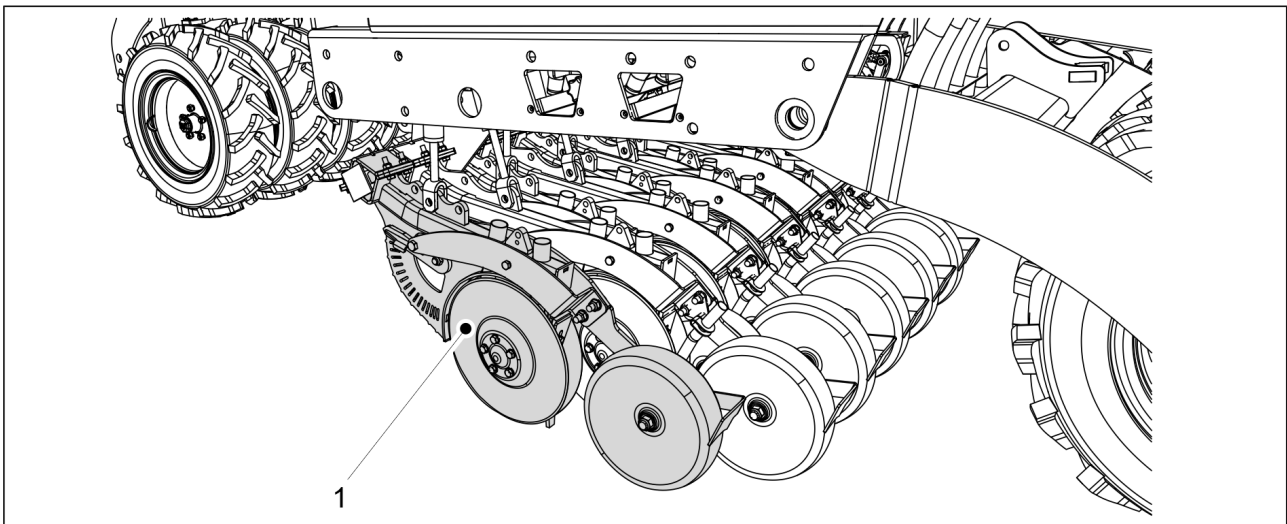

Figure. 7.9.1.1 - 299. Lowering the coulter to the ground

1. Lower the coulters to the ground and support the coulter to be dismantled (1) to its place.

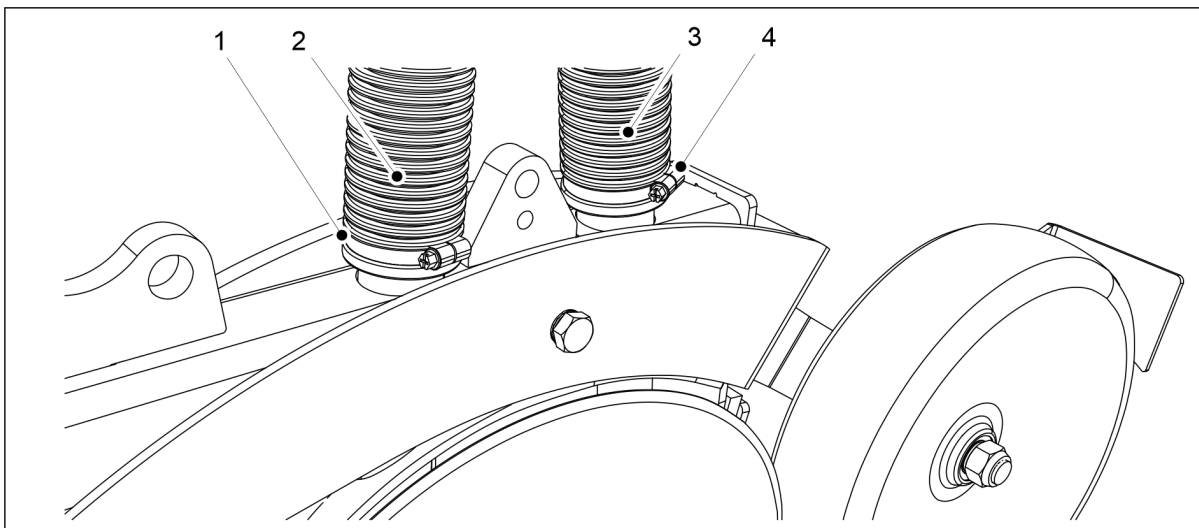

Figure. 7.9.1.1 - 300. Disconnecting coultter hoses

2. Open the hose clamps (1,4) of the hoses (2, 3) at the end of the coultter and pull the hoses off of the coultter.

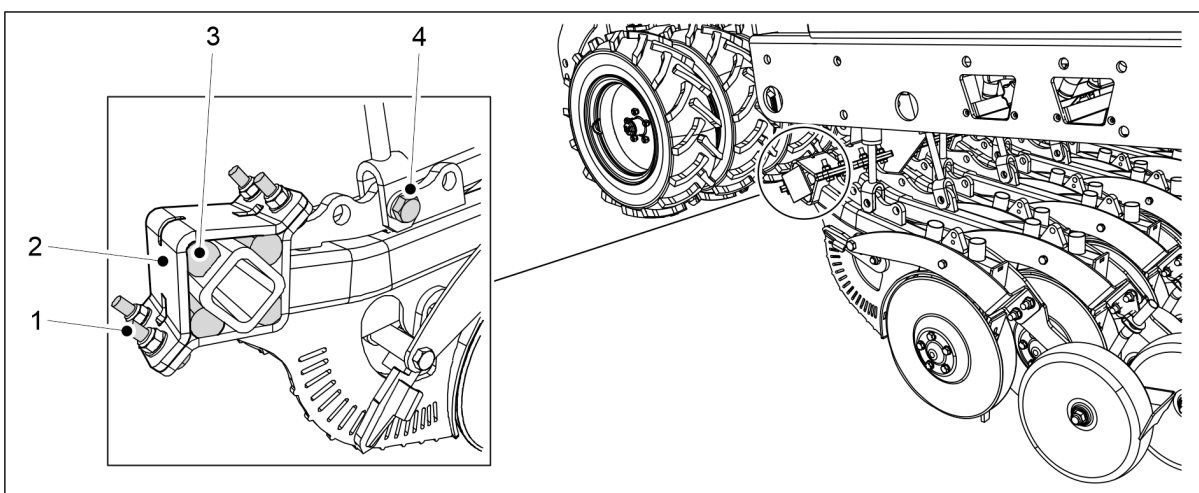

Figure. 7.9.1.1 - 301. Demounting a coultter

3. Remove the bottom cylinder mounting bolt (4) M20 X 75.
4. Loosen the four fastening bolts (1) of the coultter.
 - Do not remove the bolt right away but loosen all four bolts equally.
5. Remove the bolts (1), installation plate (2) and the four dampening rubbers (3).
6. Move the coultter away from its location.

7.9.1.2 Installing a coultter



DANGER

Use a lifting aid to lift and move the coultter. The coultter weighs approx. 60 kg and has sharp edges.

1. Move the coultter into place.

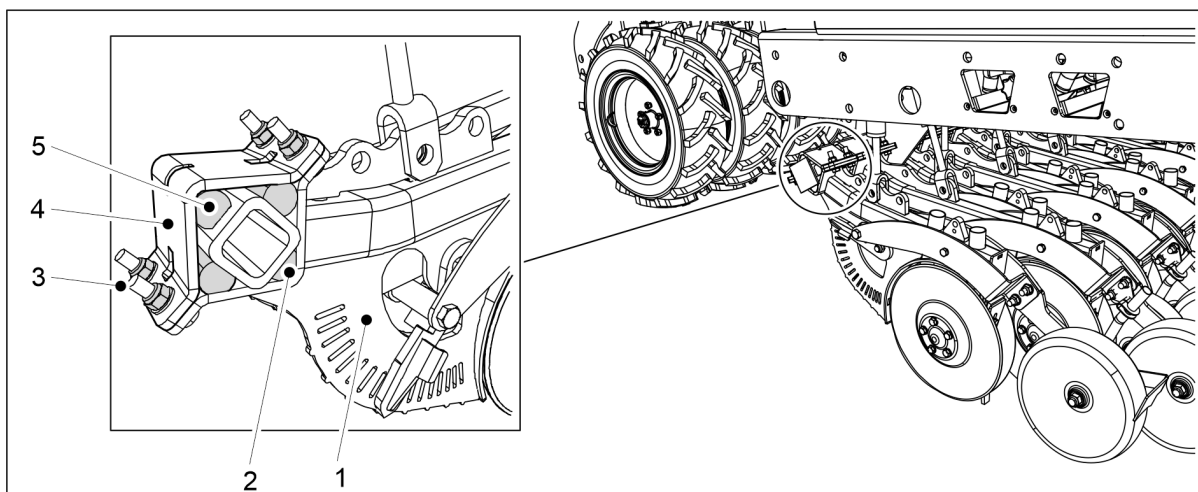

Figure. 7.9.1.2 - 302. Fastening the coulter

2. Set the lowest dampening rubber (2) in place and lift the coulter (1) against the mounting beam.
3. Install the remaining 3 rubber dampers (5).
4. Replace the washer (4).
5. Install the 4 fastening bolts and nuts (4) and tighten the bolts evenly to eliminate any gap between the mounting plates.
 - Use new locknuts with a strength rating of 10 to fasten.

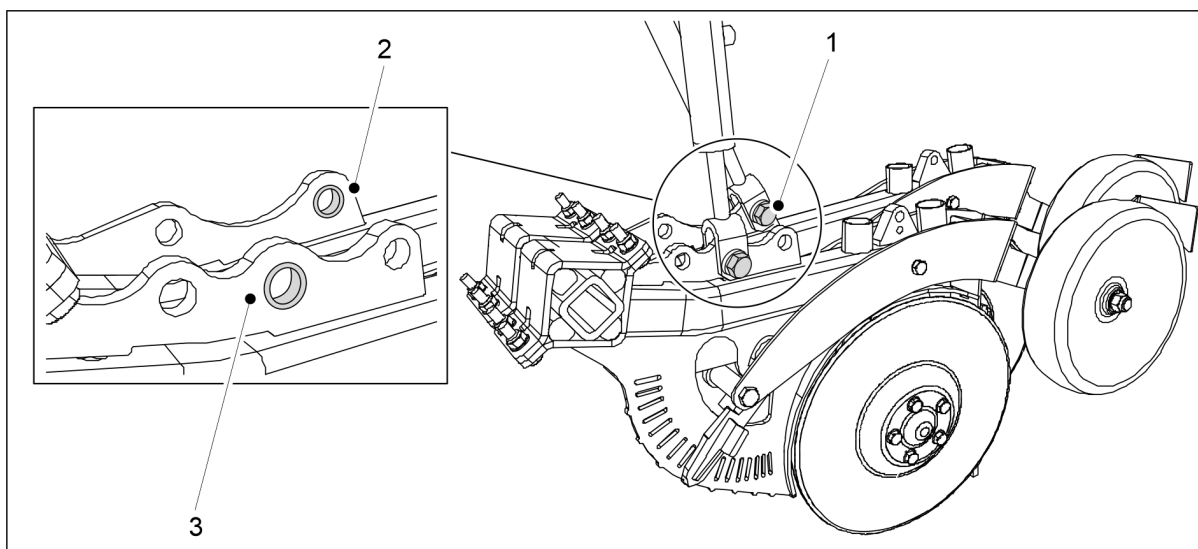

Figure. 7.9.1.2 - 303. Mounting the coulter cylinder

6. Insert the bottom cylinder bolt M20 X 75 (1) in the coulter mounting hole with the bushing.
 - Use new locknuts to fasten.

The bushing in the foremost coulter (3) is in the centremost hole. In the rearmost coulter (2) the bushing is found in the rearmost hole.

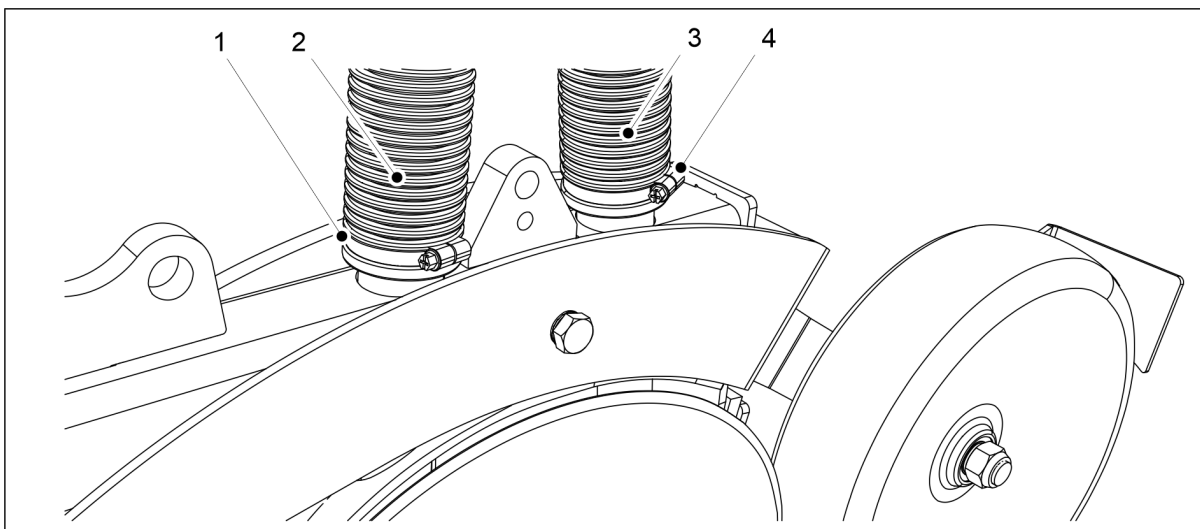

Figure. 7.9.1.2 - 304. Connecting coulters hoses

7. Connect the hoses (2,3) in the appropriate locations in the coulters.
 - The front hose (2) comes from the fertiliser hopper and the rear hose (3) comes from the seed hopper.
8. Tighten the hose clamps (1,4).

7.9.2 Replacing a coulters disc

7.9.2.1 Detaching a disc

- If necessary, demount the coulters in accordance with section [7.9.1.1 Demounting a coulters](#).

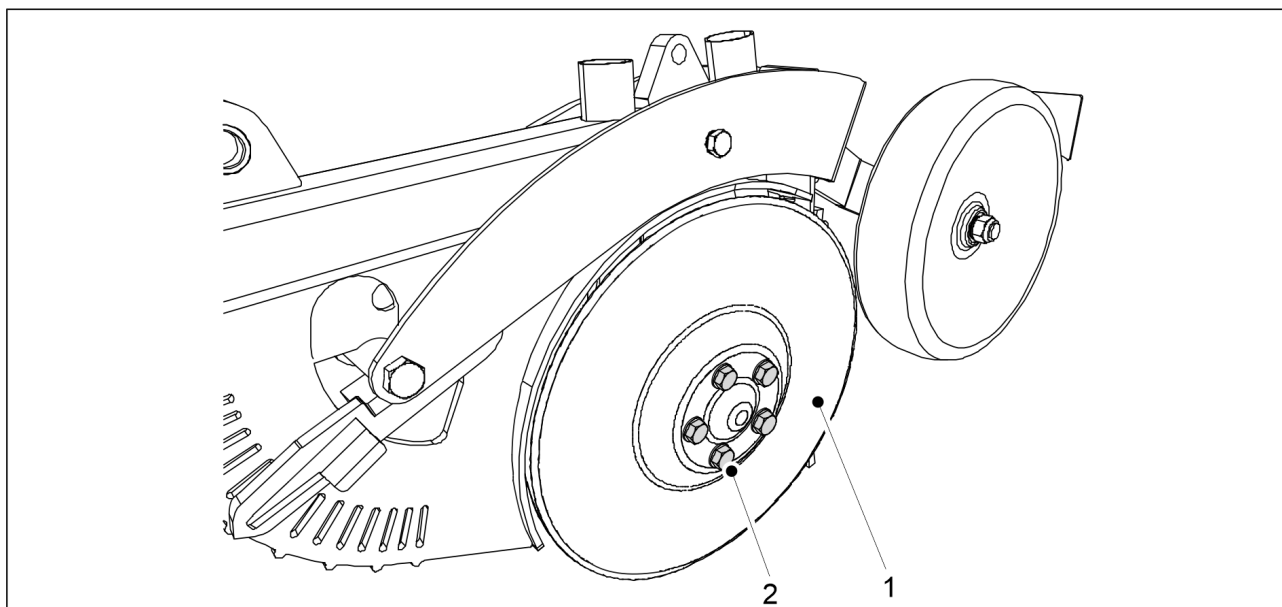

Figure. 7.9.2.1 - 305. Detaching a disc

1. Remove the mounting bolts (2) (5 pcs) of the disc (1).
 - The disc will fall off.
Replace the bearing when changing a disc.

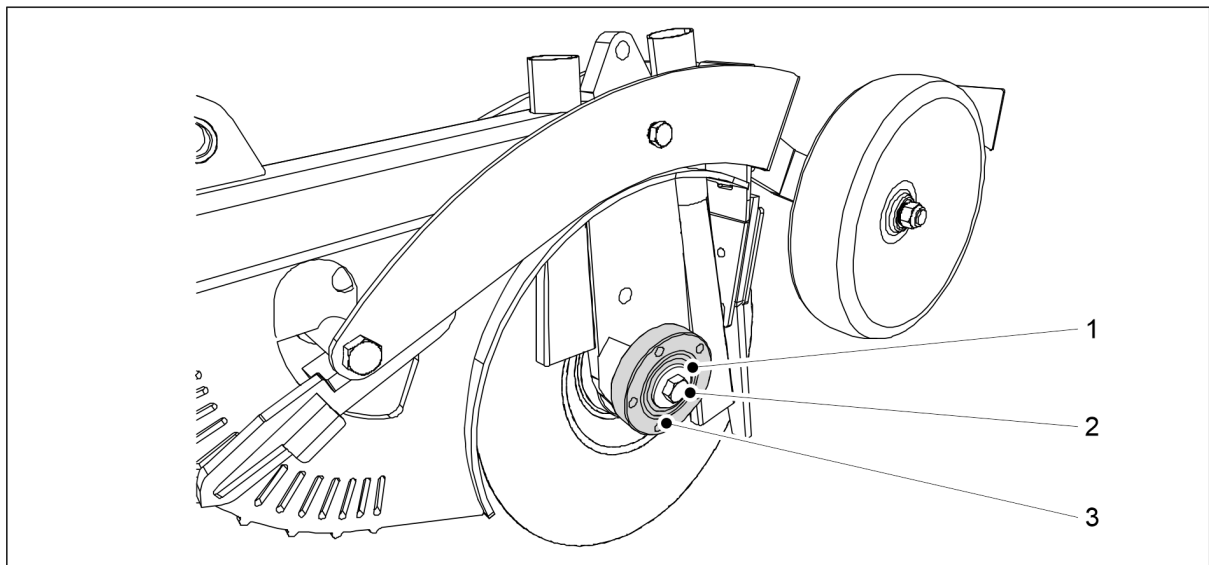

Figure. 7.9.2.1 - 306. Detaching the bearing housing

2. Loosen the bearing bolt (2) and remove the bolt and the washer (1).
 - The left-side disc has a left-hand thread and the right-side disc has a right-hand thread.
3. Remove the bearing housing (3).
 - Use a puller to remove the bearing housing.

7.9.2.2 Installing a disc

- Install the bearing in accordance with section [7.9.3.2 Installing a bearing](#).

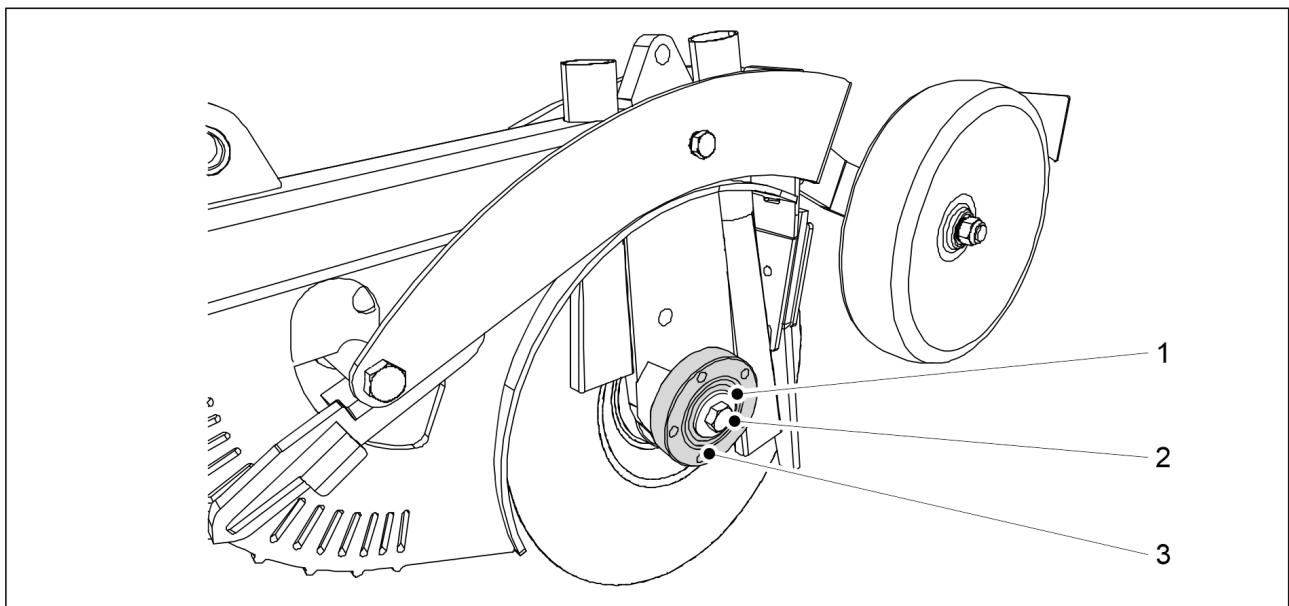

Figure. 7.9.2.2 - 307. Installing the bearing housing

1. Clean the plane surface (3) of the bearing housing.
2. Mount the bearing housing onto the coultter axle.
3. Place the M16 washer (1) and fasten the M16 bolt (2).

- The left-side disc has a left-hand thread and the right-side disc has a right-hand thread.

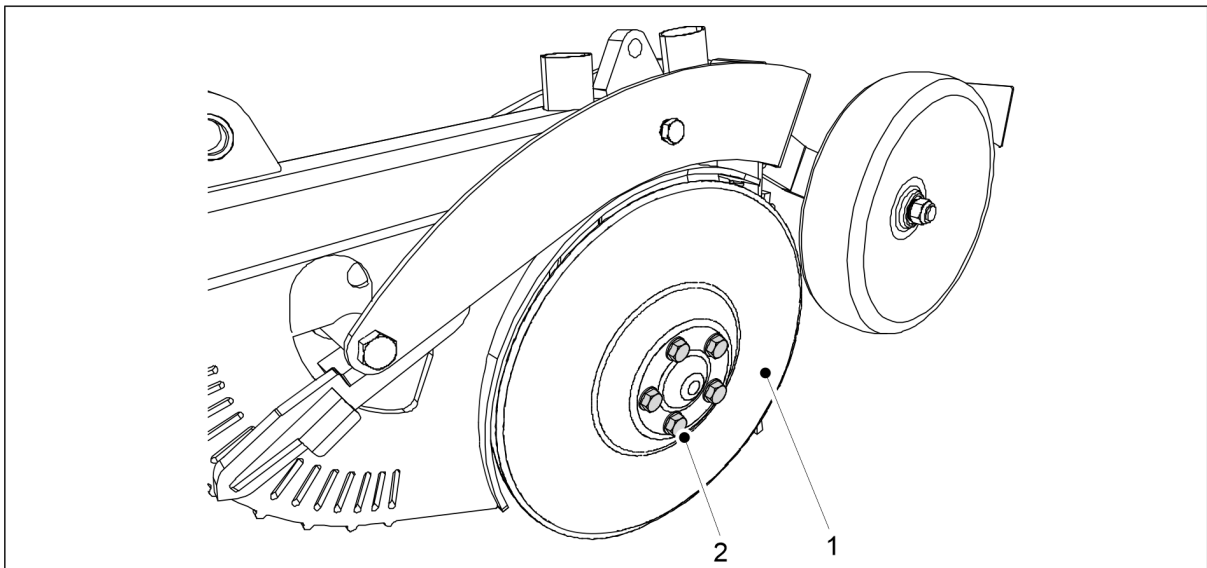

Figure. 7.9.2.2 - 308. Installing a disc

4. Mount the disc (1) onto the coulters axle.
5. Fasten the M12 x 1.5 bolts (2) (5 pcs) of the bearing cap.

7.9.3 Replacing a coulters bearing

7.9.3.1 Detaching a bearing

- Remove the coulters disc in accordance with section [7.9.2.1 Detaching a disc](#).

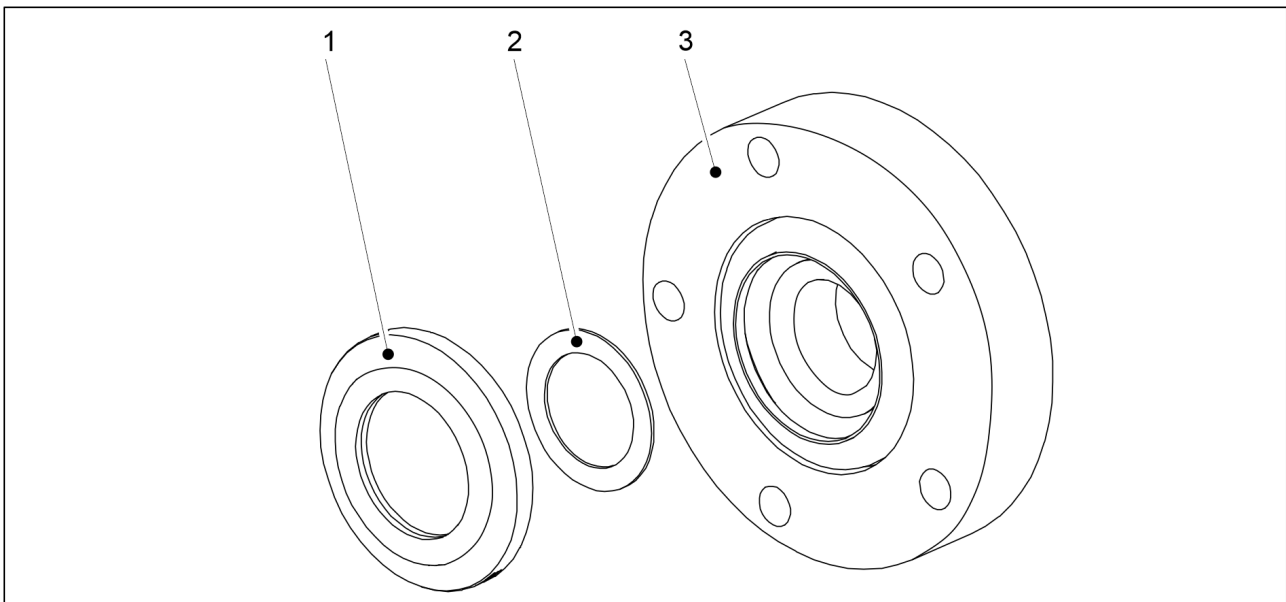

Figure. 7.9.3.1 - 309. Bearing seal and shim

1. Detach the bearing seal (1) and shim (2) from the back of the bearing housing (3).

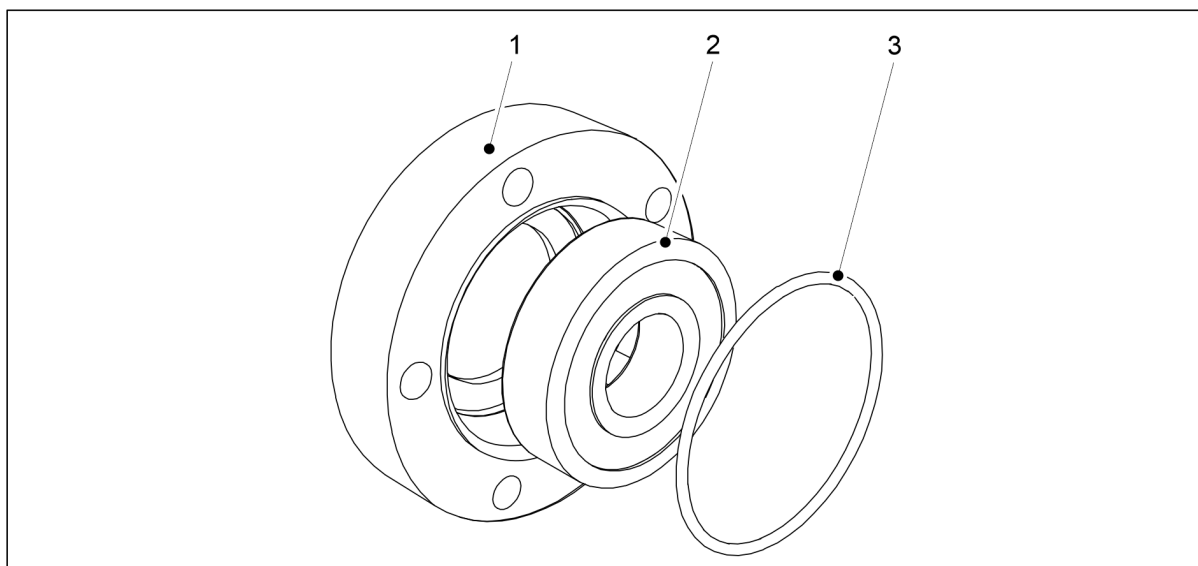

Figure. 7.9.3.1 - 310. Removing the bearing and O-ring

2. Detach the O-ring (3) from the front of the bearing.
3. Remove the bearing (2) from the bearing housing (1).
 - Detach the bearing from the back of the bearing housing using a clamp.

7.9.3.2 Installing a bearing

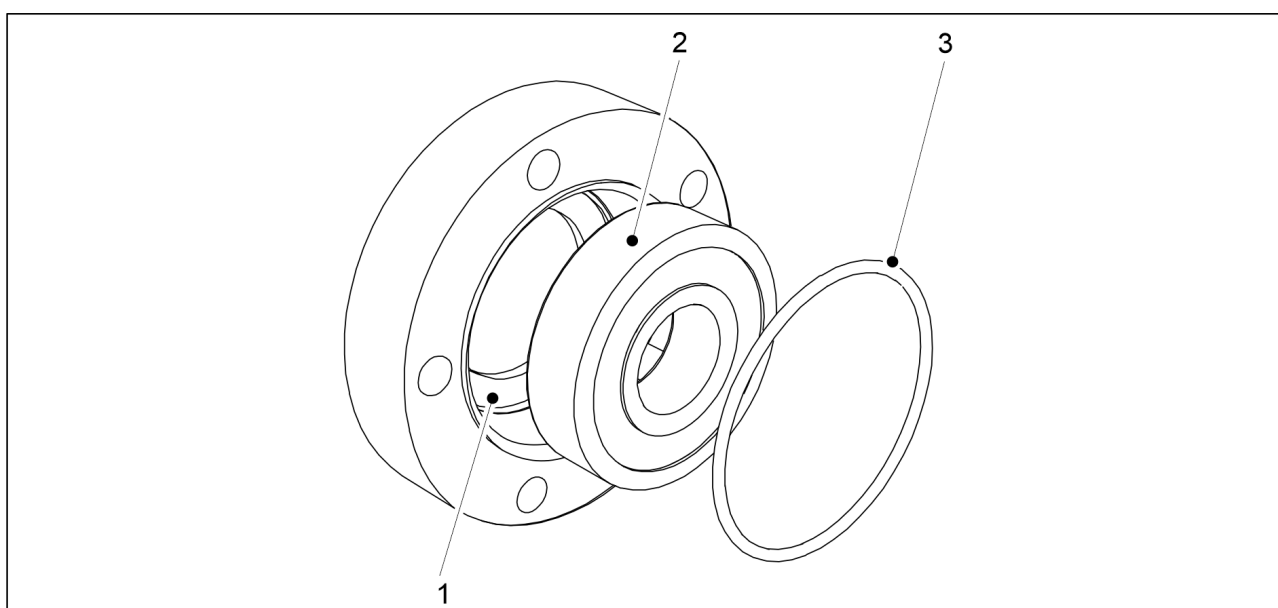

Figure. 7.9.3.2 - 311. Installing a bearing

1. Clean the bearing housing (1).
2. Install the new bearing (2).
 - Install the bearing using a clamp.
3. Replace the O-ring (3).

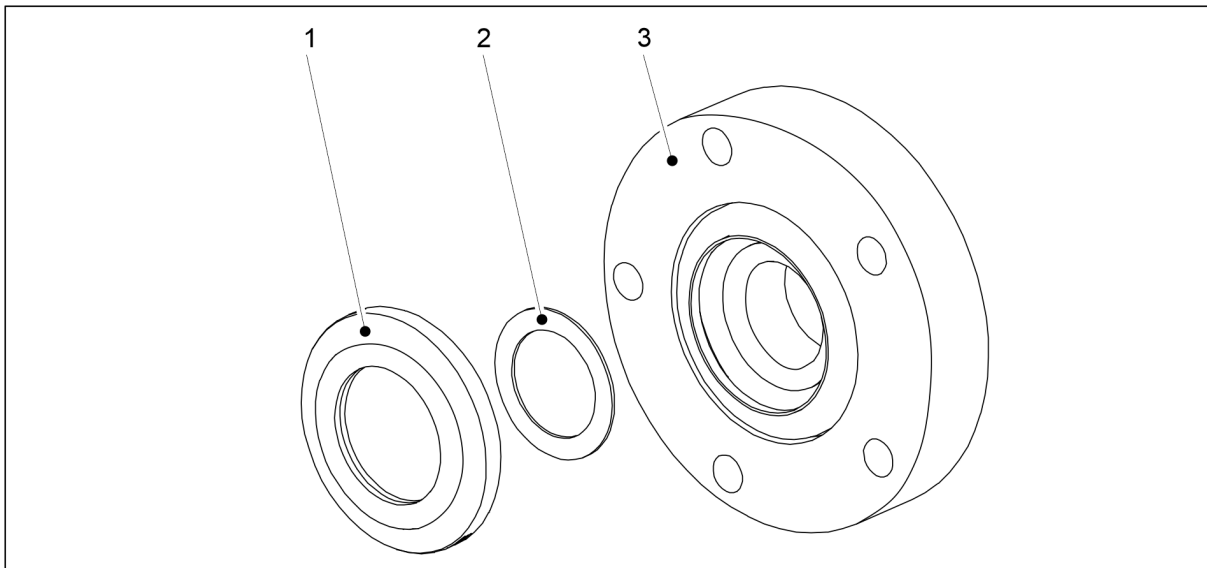

Figure. 7.9.3.2 - 312. Bearing seal and shim

4. Replace the shim (2) and bearing seal (1)(3)
 - The seal should be changed when the bearing is changed.

7.9.4 Replacing the coultter covering wheel

7.9.4.1 Demounting the covering wheel

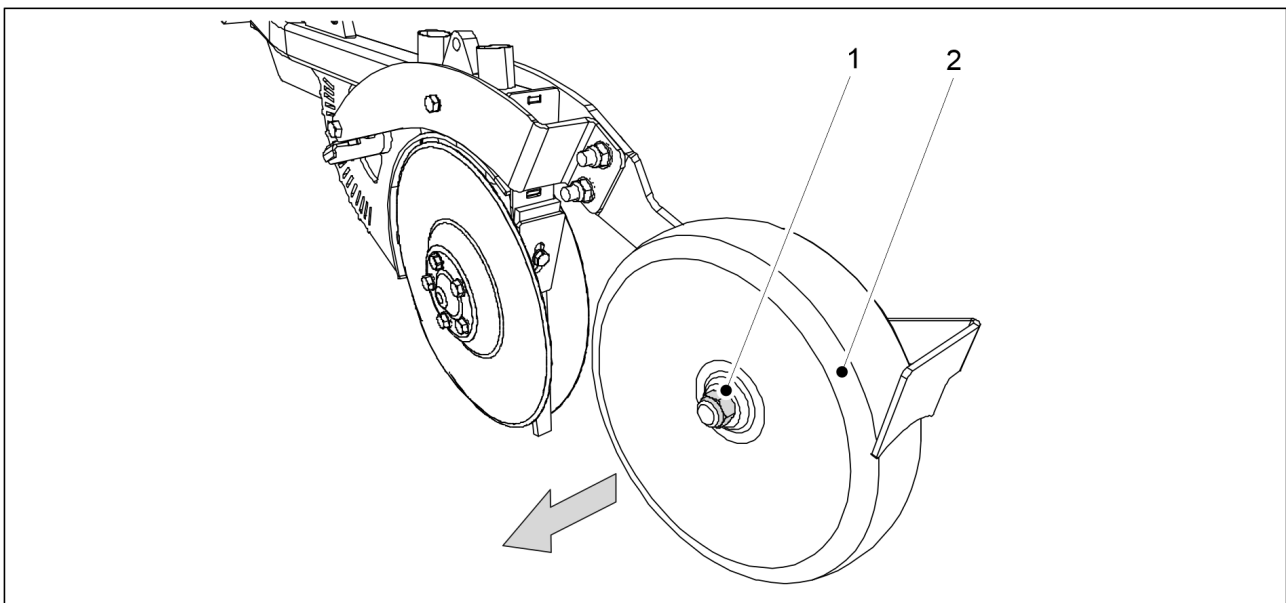

Figure. 7.9.4.1 - 313. Demounting the covering wheel

1. Remove the locknut (1) of the covering wheel (2) and pull the covering wheel off of the coultter.

7.9.4.2 Installing the covering wheel

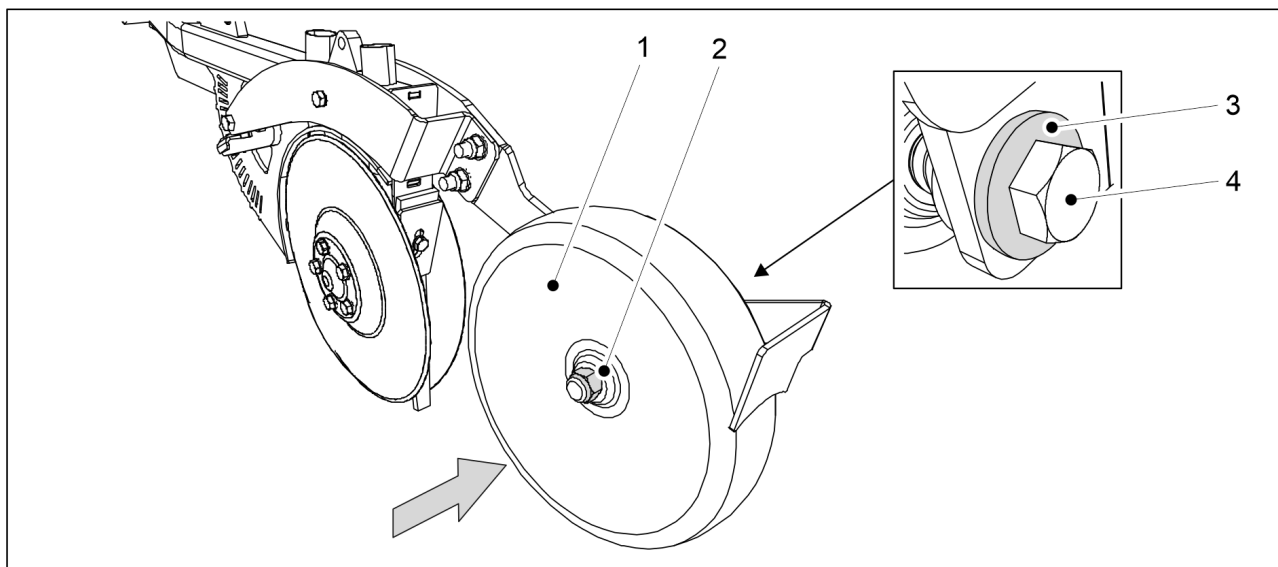

Figure. 7.9.4.2 - 314. Installing the covering wheel

1. Reattach the covering wheel (2) and fasten it with a M20 x 120 bolt (4), an M20 washer (3) and an M20 nut (2).
 - Use new locknuts when installing.

7.9.5 Adjusting the scrapers

7.9.5.1 Adjusting the disc scraper



DANGER
Use caution - the disc edges are sharp.

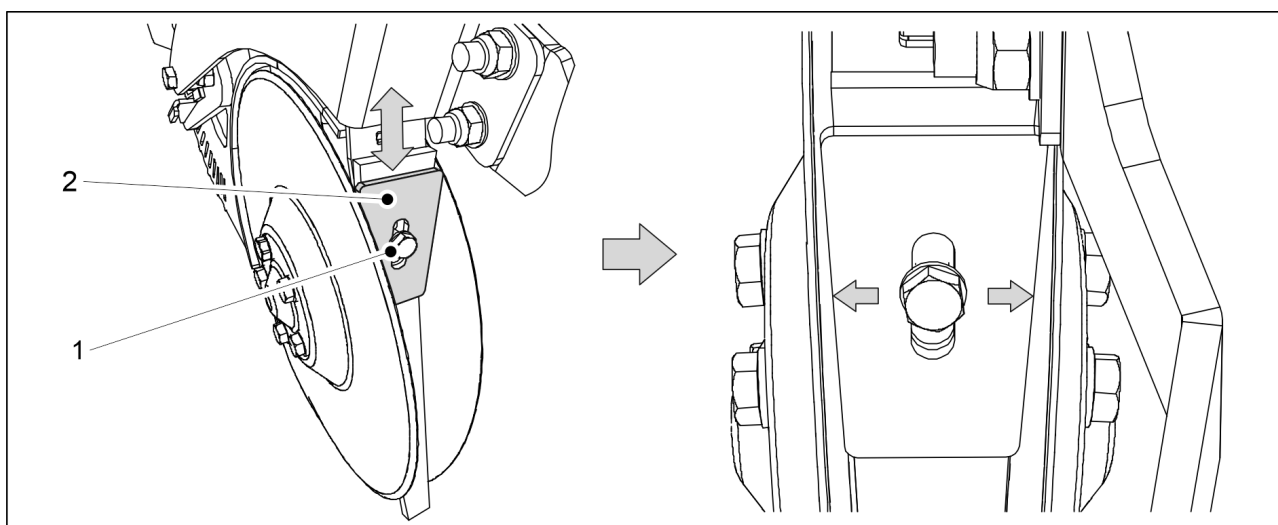

Figure. 7.9.5.1 - 315. Disc scraper

1. Loosen the bolt (1) of the scraper (2).

2. Adjust the distance between the scraper and the discs by moving the scraper up or down.
 - The scraper and inner plate under it must be kept together. Adjust the scraper and inner plate as close to the discs as possible but ensure that the disc does not make contact with the scraper or inner plate at any point. The disc must turn freely.
3. Tighten the scraper fastening bolt.

7.9.5.2 Adjusting the cover wheel scraper

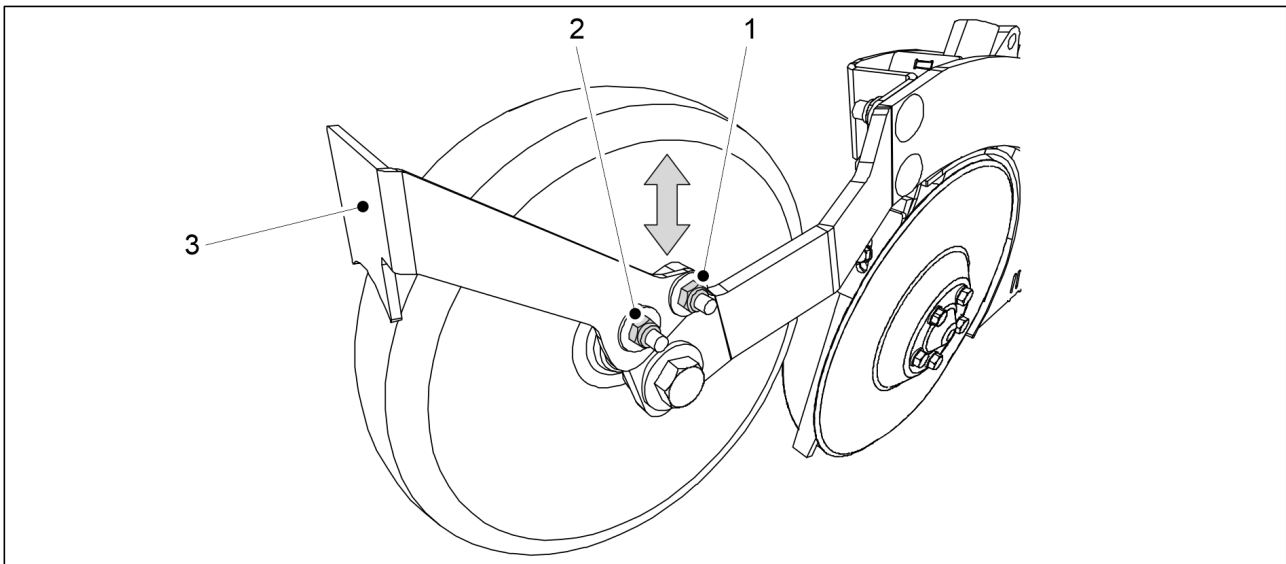

Figure. 7.9.5.2 - 316. Cover wheel scraper

1. Loosen the two fastening nuts (1, 2) of the cover wheel scraper (3)
2. Adjust the distance between the scraper and the cover wheel by moving the scraper up or down.
 - The distance between the scraper and the cover wheel should be 2- 3 mm.
3. Tighten the scraper fastening nuts.

7.10 Comfort control system maintenance

7.10.1 Manual calibration of the speed sensor

1. First, select User setup (2. User setup) on the user interface Setup screen and then Seed drill (6. Drill Setup).

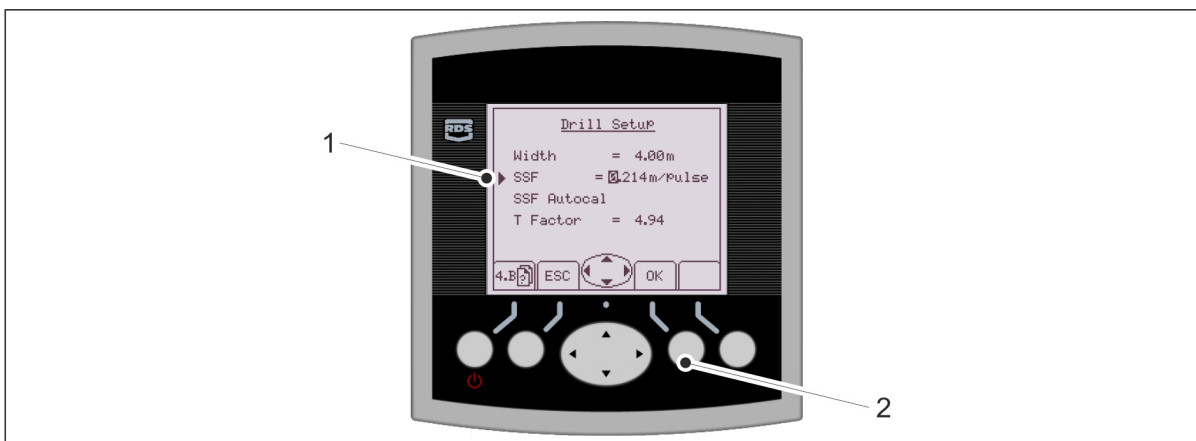

Figure. 7.10.1 - 317. Calibration start screen in the user interface

2. Move the cursor to Speed sensor (SSF) with the arrow buttons and press the OK button (1).
 - The first number starts to flash.
3. Change the value by pressing the up/down arrow keys.
4. Confirm the value by pressing right arrow key.
5. Repeat steps 3-4 for the other numbers.
6. Confirm the correction by pressing the OK button (2).

7.10.2 Calibration of the speed sensor while driving

1. Select User setup and Seed drill on the user interface.

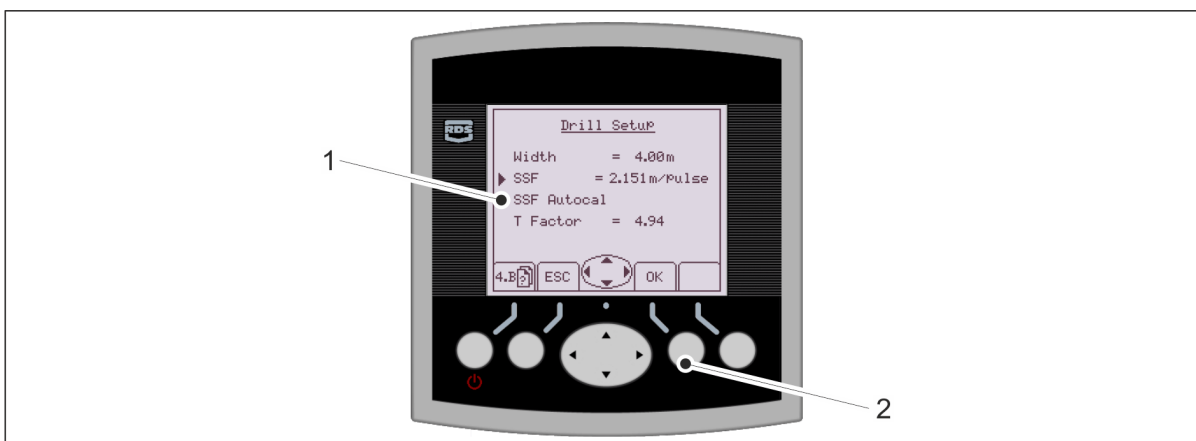

Figure. 7.10.2 - 318. Calibration start screen in the user interface

2. Move the cursor to Speed sensor (SSF Autocal) (1) and press the OK button (2).



Figure 7.10.2 - 319. Driving with a tractor - start

3. Press the OK key (1).
4. Drive 100 metres with the tractor.



Figure 7.10.2 - 320. Driving with a tractor - end

5. Press the OK key (2).
 - The new calibrated value (1) appears on the screen.
6. Accept by pressing the OK button (2) or rerun the calibration by pressing the ESC button (3).

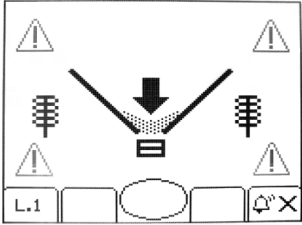
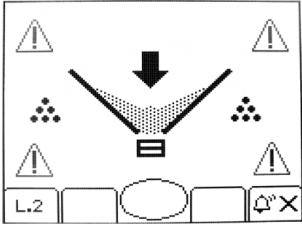
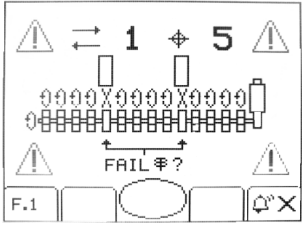
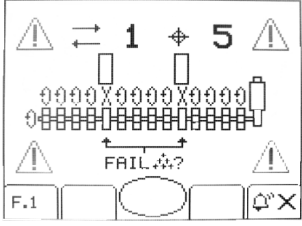
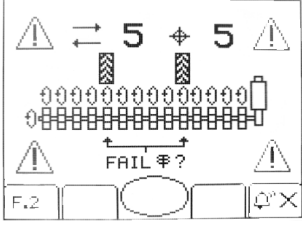
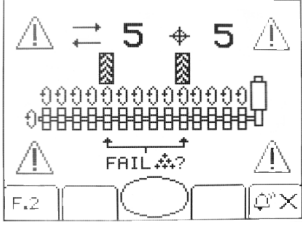

Figure 7.10.2 - 321. New calibrated value

- The new calibrated value (1) appears on the screen.

8 Fault situations

8.1 Troubleshooting the Comfort control system

Error	Display	Measures
Seed level in the hopper is too low.		Fill the seed hopper.
Fertiliser level in the hopper is too low.		Fill the fertiliser hopper.
The tramline seed clutch is not working and no pulses are coming from the seed shaft.		Check that the shaft rotates. Check the sensors.
The tramline fertiliser clutch is not working and no pulses are coming from the seed shaft.		Check that the shaft rotates. Check the sensors.
The tramline seed clutch is not working and pulses are coming from the seed shaft while making a tramline.		Check that the shaft does not rotate. Check the sensors.
The tramline fertiliser clutch is not working and pulses are coming from the seed shaft while making a tramline.		Check that the shaft does not rotate. Check the sensors.

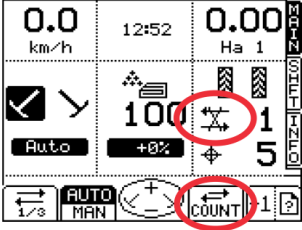
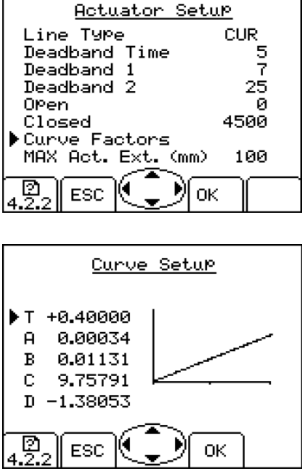
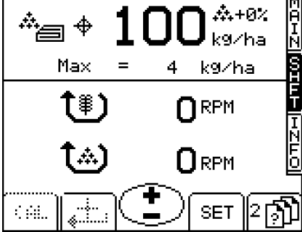
<p>The middle marker automation or tramline counter is not working. The tramline counter is set to the STOP position.</p>		<p>Ensure that the checks shown in the figure are NOT on the arrows.</p>
<p>The linear actuator for the adjusting of the fertiliser target rates at 0 and not moving. The fertiliser calibration has failed and is outside the T-value limits.</p>		<p>On the Settings screen, select 3. Factory Setup → enter the PIN code 1234 → select 2. Actuator Setup → select CUR as your Line Type setting → select Curve Factors → set the T-value manually.</p> <p>If only "#####" is shown on the line, go to the line by pressing OK. First enter "000000" as the value and then accept it by pressing the OK button. The value "0.00000" should now appear on the line.</p> <p>Repeat the above and enter "0.40000" as the value.</p>
<p>The middle markers do not work automatically or in the manual position.</p> <p>A new value has been entered for the fertiliser rate and the linear actuator has not reached the target.</p>		<p>Check the function of the adjusting of the fertiliser target rate according to section 7.1.14 Checking the functioning of the adjusting of the fertiliser target rate.</p>

8.2 Troubleshooting of the seed drill

Table. 8.2 - 27. Troubleshooting of the seed drill

Problem	Cause	Measures
The quantity of seed or fertiliser fed by the machine is higher than indicated by the calibration test.	1. The bottom flaps of the feeder units are incorrectly adjusted	1. Check the fertiliser hopper according to section 6.6.7.1 Adjusting the bottom flap position , the seed hopper according to section 6.6.8.1 Adjusting the bottom flap position and the small seed hopper according to section 6.6.9.1 Adjusting the bottom flap position .
	2. The calibration test table is indicative	2. Check the feeding quantity by means of the calibration test in accordance with section 6.8 Product calibration .
	3. Seed moves in a different manner at the beginning and after a few hectares	3. Run a calibration test again in accordance with section 6.8 Product calibration after a few hectares, particularly at the beginning of the season.
The quantity of seed or fertiliser fed by the machine is lower than indicated by the calibration test.	1. The bottom flaps of the feeder units are incorrectly adjusted	1. Check the fertiliser hopper according to section 6.6.7.1 Adjusting the bottom flap position , the seed hopper according to section 6.6.8.1 Adjusting the bottom flap position and the small seed hopper according to section 6.6.9.1 Adjusting the bottom flap position .
	2. The calibration test table is indicative	2. Check the feeding quantity by means of the calibration test in accordance with section 6.8 Product calibration .
	3. The seed or fertiliser bridging has occurred in the hopper.	3. Ensure that the fertiliser is not clumping and there is no excess material in the hopper.
	4. The feeder roller is obstructed.	4. Clean the feeder roller in accordance with section 7.3.5 Cleaning the feeder units or section 7.3.6 Cleaning of the small seed hopper feeder units .
	5. The wheel drive operation is compromised	5. Check the function of the wheel drive in accordance with the instructions in section 7.1.6 Checking the tightness of the wheel drive chain , section 7.1.7 Inspecting the wheel drive clutch and section 7.1.8 Inspecting the wheel drive clutch

The machine cannot be lifted	1. The lift inhibit function is on	1. Disable the lift inhibit function in accordance with section <u>6.3.1 Active operating mode</u> .
	2. Machine lifting circuit ball valve is closed	2. Open the machine lifting circuit ball valve in accordance with section <u>5.3.5 Using the machine lifting circuit ball valve</u> .
	3. The quick coupling is open	3. Check the connection of the quick-release coupling.
The machine cannot be lowered	1. Machine lifting circuit ball valve is closed	1. Open the machine lifting circuit ball valve in accordance with section <u>5.3.5 Using the machine lifting circuit ball valve</u> .
	2. The quick coupling is open	2. Check the connection of the quick coupler
	3. The stoppers are in place in the lifting cylinder	3. Remove the stoppers from the lifting cylinder.
Hopper alarm does not function	1. The alarm has been disabled	1. Enable the alarm from the settings in accordance with section <u>4.1.4.5 Setting alarms</u> .
The axle rotation guard does not function	1. The alarm has been disabled	1. Enable the alarm from the settings in accordance with section <u>4.1.4.5 Setting alarms</u> .

9 Attachments

1. EC Declaration of Conformity
2. Hydraulic schematics
3. Electrical schematics
4. Connection socket according to SFS 2473
5. Calculating the stability of the tractor - seed drill combination

EC DECLARATION OF CONFORMITY

DOMETAL OY

Kotimäentie 1
FI-32210 Loimaa
Finland

hereby states that the following seed drills in question

Multiva CEREX 300 EVO starting from serial number 000-091403-P1000001

Multiva CEREX 400 EVO starting from serial number 000-091404-P1000001

Multiva FORTE 300 EVO starting from serial number 000-091303-P1000001

Multiva FORTE 400 EVO starting from serial number 000-091304-P1000001

meet the requirements of Machinery Directive 2006/42/EC with respect to the construction of machinery.

Furthermore, the following standards were applied in the design of the machine:

SFS-EN 12100 (2010)

SFS-EN 14018 + A1 (2010)

SFS-EN ISO 4254-1 (2013)

Loimaa, 8 November 2022



Vesa Mäkelä
Kotimäentie 1
FI-32210 Loimaa
Finland

The undersigned is also authorised to compile technical documentation for the above machines.
Translation of the original file

Hydraulic schematics FORTE 300 EVO

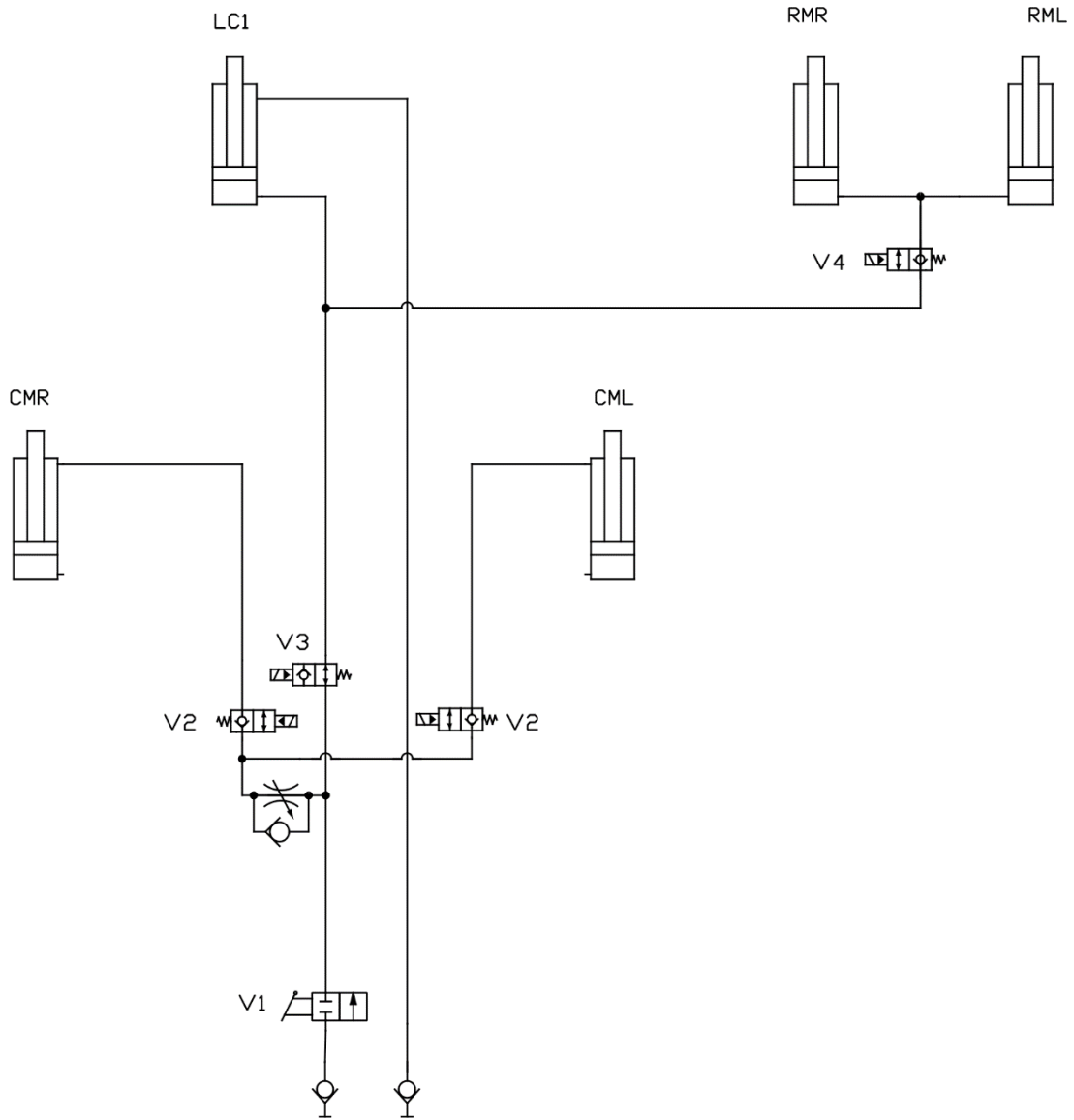

Lifting and lowering the machine (LC)
with middle markers (CMR/CML) and rear markers (RMR/RML)

Hydraulic schematics FORTE 300 EVO

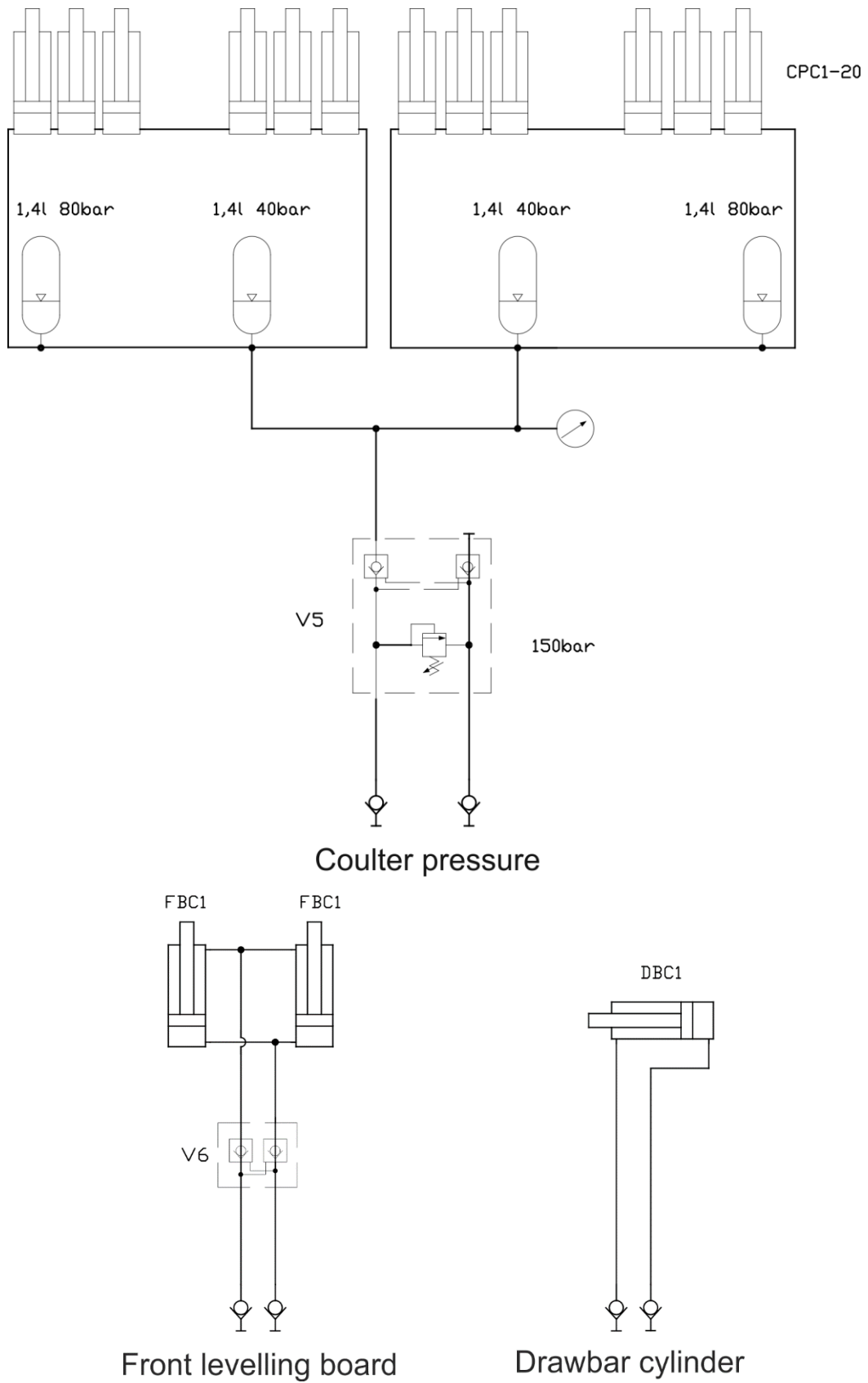

Hydraulic schematics FORTE 400 EVO

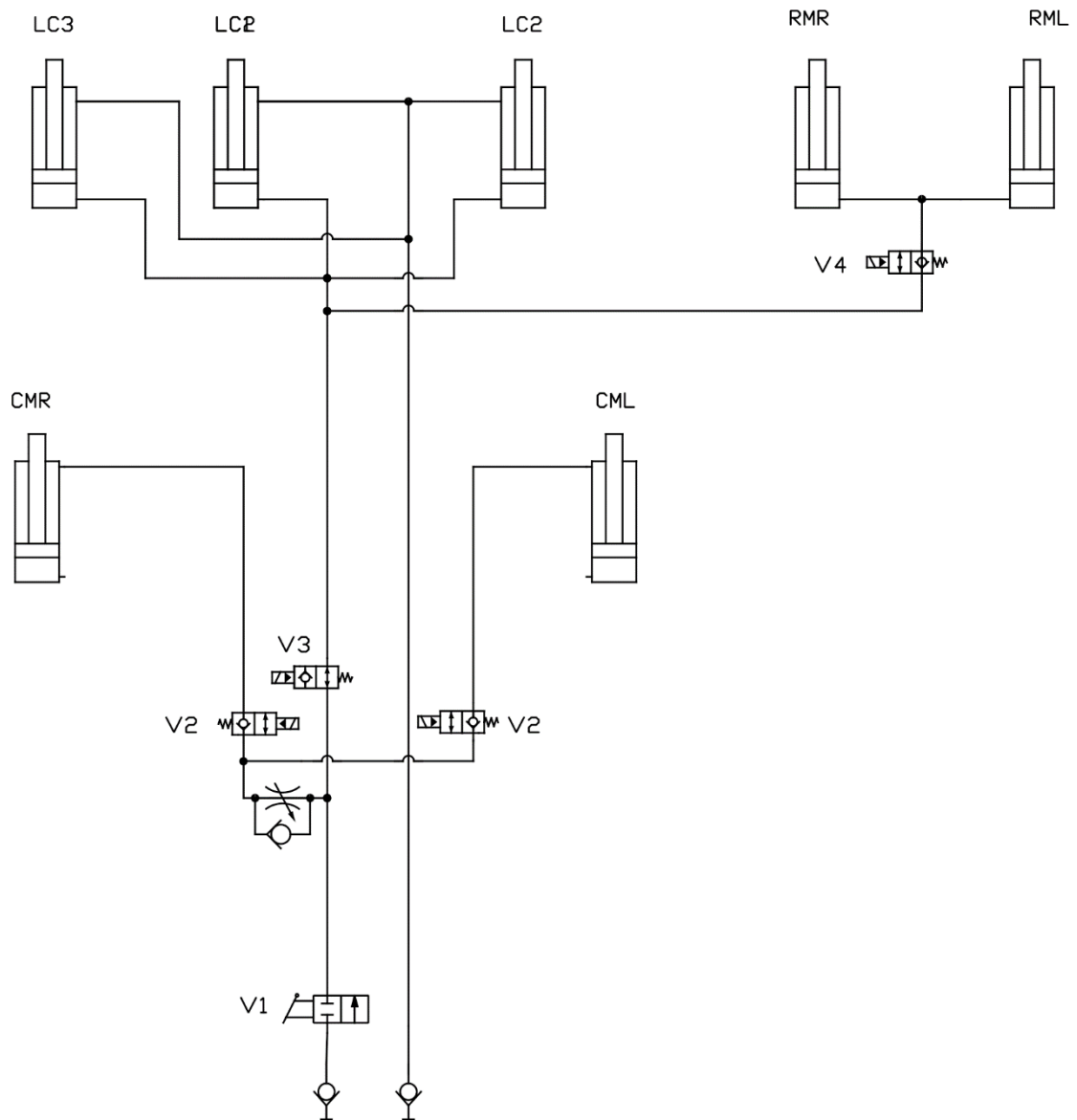

Lifting and lowering the machine (LC)
with middle markers (CMR/CML) and rear markers (RMR/RML)

Hydraulic schematics FORTE 400 EVO

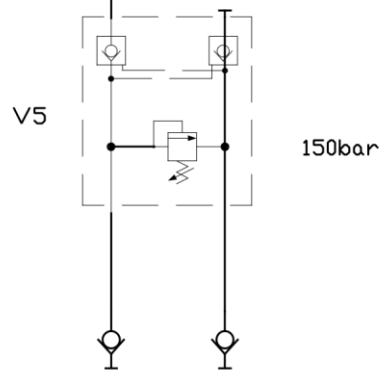
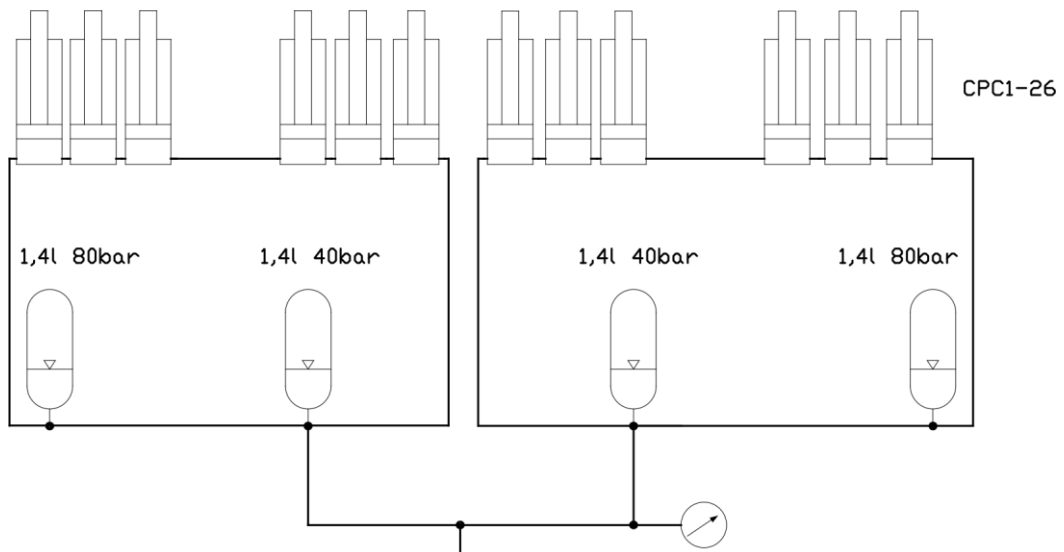

Coulter pressure

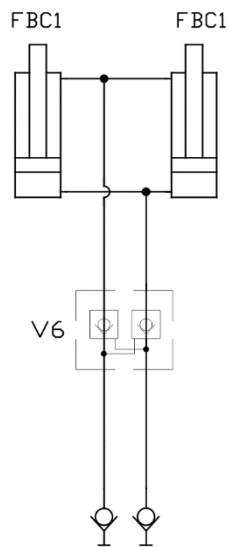

Front levelling board

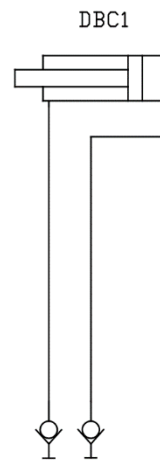

Drawbar cylinder

Hydraulic schematics FORTE 300-400 EVO

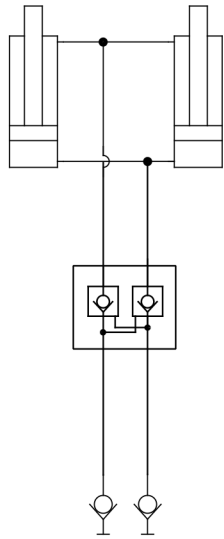

Front disc cultivator

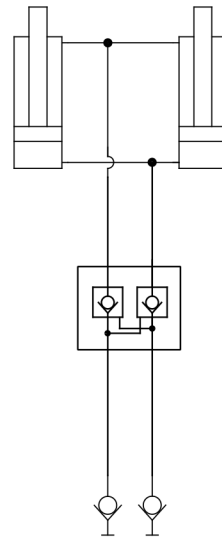

Front harrow

Electrical schematics

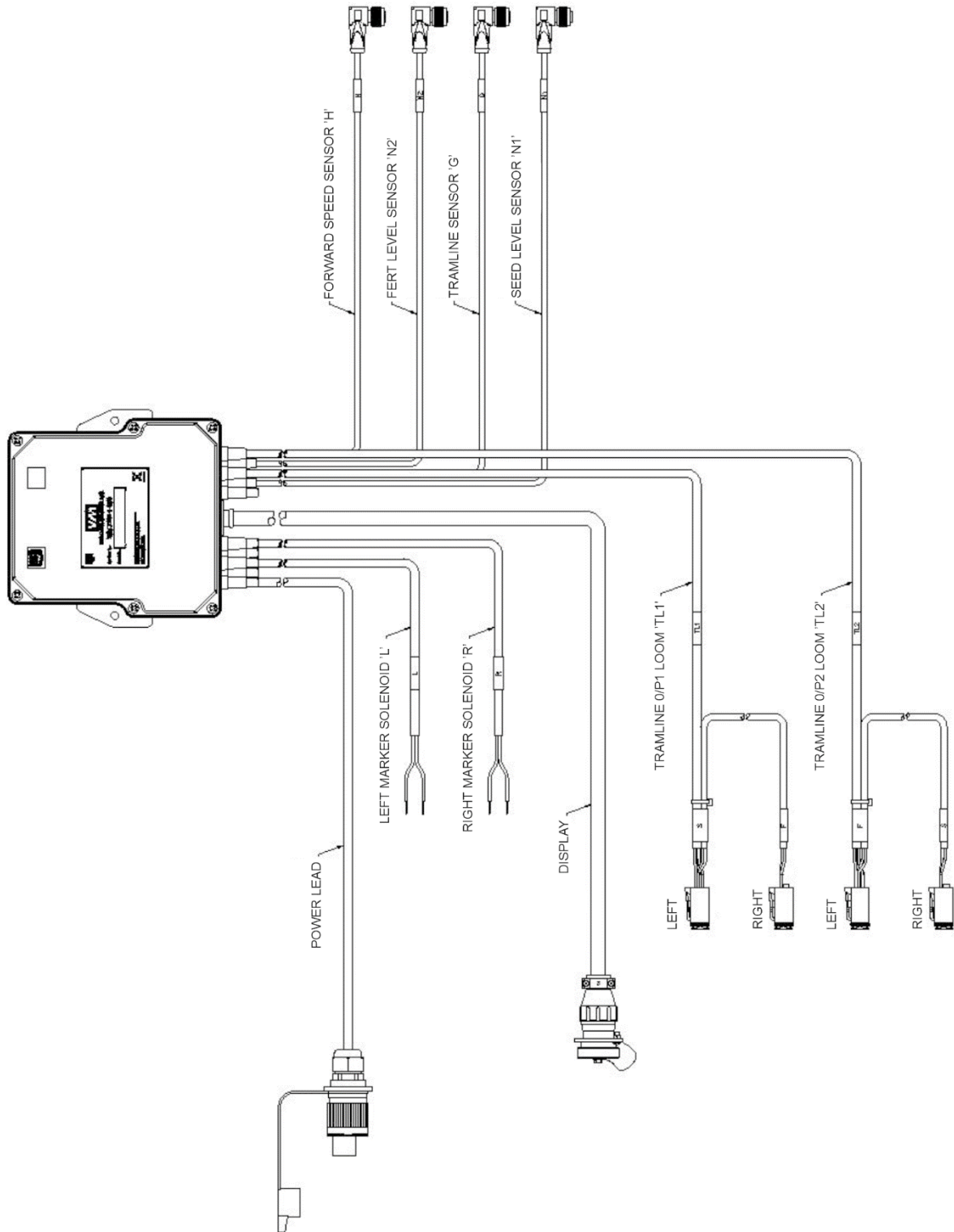

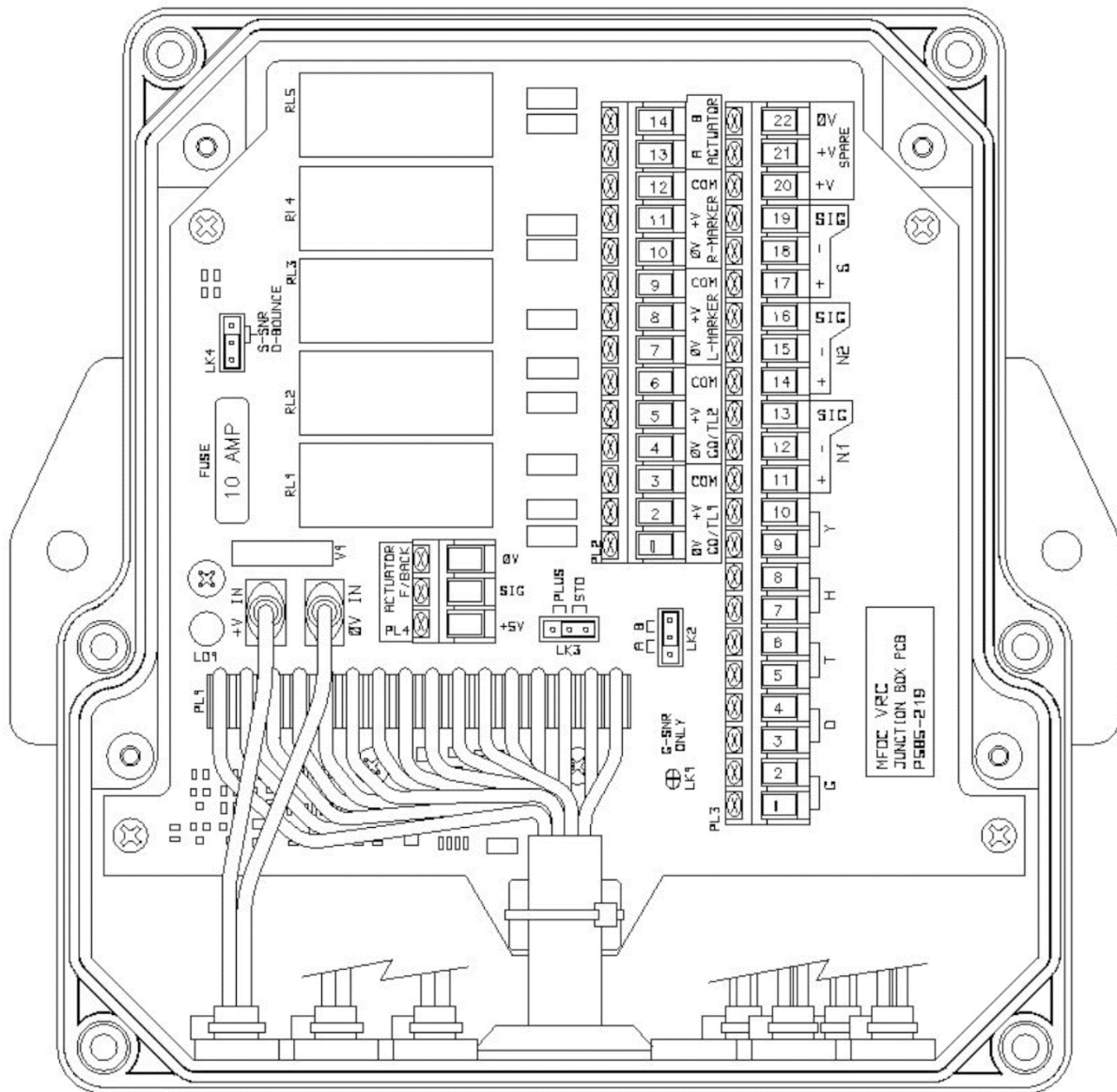

If lift inhibit, move
 PL2-5 -> PL2-2 and
 PL2-6 -> PL2-3
 Lift inhibit coil will be
 connected to PL2-5
 and PL2-6

PCB link information	
LK1	Soldered
LK2	Jumper pre-fitted in position 'B'
LK3	Jumper pre-fitted in position 'STD' Fertiliser remote control 'PLUS'
LK4	Jumper pre-fitted positioned on 2 pins closest to the fuse
LK5)

PCB internal wiring			
Cable assembly	Core colour	PCB position	Function
Power lead	Brown	+V IN	+V
	Blue	0V IN	0V
Tramline loom (TL1)	Blue	PL2 – 2	Solenoids +V
	Red	PL2 – 3	Solenoids 0V
	Green	PL3 – 18	Rotation guard 0V
	Yellow	PL3 – 19	Rotation guard SIG
Tramline loom (TL2)	Blue	PL2 – 5	Solenoids 0/P2 +V
	Red	PL2 – 6	Solenoids /P2 0V
	Green	PL3 – 5	Rotation guard 0/P2 0V
	Yellow	PL3 – 6	Rotation guard 0/P2 SIG
Left marker solenoid (L)	Brown	PL2 – 8	Left marker solenoid +V
	Blue	PL2 – 9	Left marker solenoid 0V
Right marker solenoid (R)	Brown	PL2 – 11	Right marker solenoid +V
	Blue	PL2 – 12	Right marker solenoid 0V
Tramline sensor (G)	Blue	PL3 – 1	Tramline sensor 0V
	Black	PL3 – 2	Tramline sensor SIG
	Brown	PL3 – 20	Tramline sensor +V
Forward speed sensor (H)	Blue	PL3 – 7	Forward speed sensor 0V
	Black	PL3 – 8	Forward speed sensor SIG
	Brown	PL3 – 21	Forward speed sensor +V
Seed level sensor (N1)	Brown	PL3 – 11	Seed level sensor +V
	Blue	PL3 – 12	Seed level sensor 0V
	Black	PL3 – 13	Seed level sensor SIG
Fert level sensor (N2)	Brown	PL3 – 14	Fert level sensor +V
	Blue	PL3 – 15	Fert level sensor 0V
	Black	PL3 – 16	Fert level sensor SIG

Connection socket according to SFS 2473

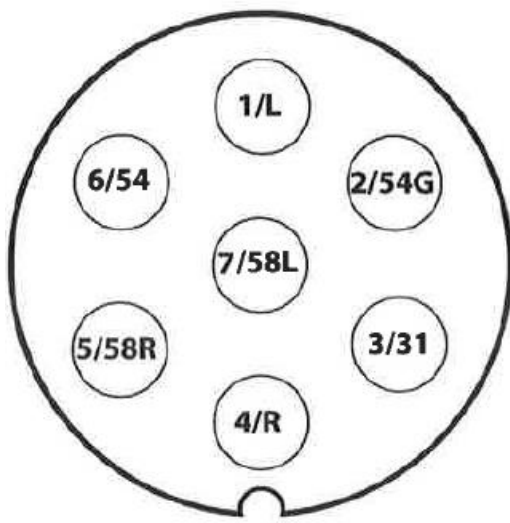

1/L	Left turn signal
2/54G	Free
3/31	Ground
4/R	Right turn signal
5/58R	Right rear light + lic. plate light
6/54	Brake light
7/58L	Left rear light

Calculating the stability of the tractor - seed drill combination

The load may impact the steerability of the tractor. The dead weight of the machine and the materials in the hoppers may result in the loss of the stability of the tractor - seed drill combination.

This Appendix provides a recommendation on how to ensure the stability of the tractor - seed drill combination by means of calculation.

The following formula can be used to calculate the tractor's minimum weight $I_{F,min}$, which will allow the load on the front axle to be 20% of the weight of an empty tractor:

$$I_{F,min} = \frac{(I_R \times (c+d)) - (T_F \times b) + (0,2 \times T_E \times b)}{a+b}, \text{ in which}$$

T_E	[kg]	Tractor's dead weight ¹⁾
T_F	[kg]	Front axle load of an empty tractor ¹⁾
T_R	[kg]	Rear axle load of an empty tractor ¹⁾
I_R	[kg]	Total weight of the implement or rear ballast installed in the rear ²⁾
I_F	[kg]	Total weight of the implement or front installed in the front ²⁾
a	[m]	Distance between the centre of mass of the implement or front ballast installed in the front and the centre of the front axle ^{2) 3)}
b	[m]	Tractor's wheelbase ¹⁾
c	[m]	Distance between the centre of the rear axle and the centre of the connecting point of the link arm ^{1) 3)}
d	[m]	Distance between the centre of the connecting point of the link arm and the centre of mass of the implement or rear ballast installed in the rear ²⁾

- 1) See the tractor manual
- 2) See the implement manual
- 3) To be measured

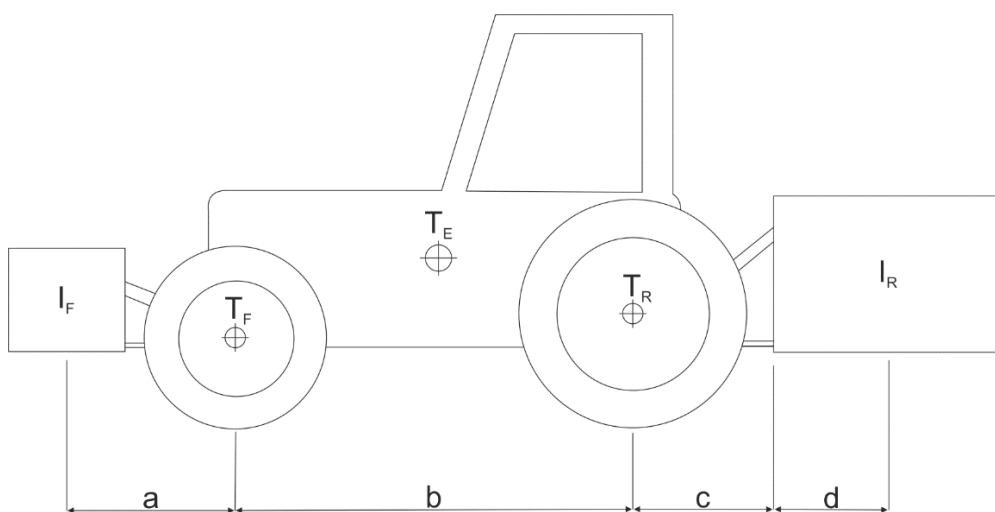

Figure 1. Calculating the stability of the tractor - seed drill combination